



Chipsmall Limited consists of a professional team with an average of over 10 year of expertise in the distribution of electronic components. Based in Hongkong, we have already established firm and mutual-benefit business relationships with customers from,Europe,America and south Asia,supplying obsolete and hard-to-find components to meet their specific needs.

With the principle of “Quality Parts,Customers Priority,Honest Operation,and Considerate Service”,our business mainly focus on the distribution of electronic components. Line cards we deal with include Microchip,ALPS,ROHM,Xilinx,Pulse,ON,Everlight and Freescale. Main products comprise IC,Modules,Potentiometer,IC Socket,Relay,Connector.Our parts cover such applications as commercial,industrial, and automotives areas.

We are looking forward to setting up business relationship with you and hope to provide you with the best service and solution. Let us make a better world for our industry!



Contact us

Tel: +86-755-8981 8866 Fax: +86-755-8427 6832

Email & Skype: info@chipsmall.com Web: www.chipsmall.com

Address: A1208, Overseas Decoration Building, #122 Zhenhua RD., Futian, Shenzhen, China



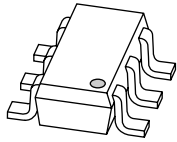

PMEM4020APD

PNP transistor/Schottky rectifier module

Rev. 02 — 31 August 2009

Product data sheet

1. Product profile

1.1 General description

Combination of a PNP transistor with low V_{CEsat} and high current capability and a planar Schottky barrier rectifier with an integrated guard ring for stress protection in a SOT457 (SC-74) small plastic package. NPN complement: PMEM4020AND

1.2 Features

- 600 mW total power dissipation
- High current capability up to 2 A
- Reduces printed-circuit board area required
- Reduces pick and place costs
- Small plastic SMD package
- Transistor
 - ◆ Low collector-emitter saturation voltage
- Diode
 - ◆ Ultra high-speed switching
 - ◆ Very low forward voltage
 - ◆ Guard ring protected

1.3 Applications

- DC-to-DC converters
- Inductive load drivers
- General purpose load drivers
- Reverse polarity protection circuits
- MOSFET drivers

1.4 Quick reference data

Table 1. Quick reference data

Symbol	Parameter	Conditions	Min	Typ	Max	Unit
PNP transistor						
V_{CEO}	collector-emitter voltage	open base	-	-	-40	V
I_C	collector current (DC)	continuous; $T_s \leq 55\text{ °C}$	[1] -	-	-2	A

Table 1. Quick reference data ...continued

Symbol	Parameter	Conditions	Min	Typ	Max	Unit
Schottky barrier rectifier						
V_R	continuous reverse voltage		-	-	40	V
I_F	continuous forward current		-	-	1	A

[1] Soldering point of collector or cathode tab.

2. Pinning information

Table 2. Discrete pinning

Pin	Description	Simplified outline	Symbol
1	emitter		<p style="text-align: right;"><i>sym040</i></p>
2	not connected		
3	cathode		
4	anode		
5	base		
6	collector		

3. Ordering information

Table 3. Ordering information

Type number	Package		
	Name	Description	Version
PMEM4020APD	SC-74	plastic surface mounted package; 6 leads	SOT457

4. Marking

Table 4. Marking

Type number	Marking code
PMEM4020APD	D3

5. Limiting values

Table 5. Limiting values

In accordance with the Absolute Maximum Rating System (IEC 60134).

Symbol	Parameter	Conditions	Min	Max	Unit
PNP transistor					
V_{CBO}	collector-base voltage	open emitter	-	-40	V
V_{CEO}	collector-emitter voltage	open base	-	-40	V
V_{EBO}	emitter-base voltage	open collector	-	-5	V

Table 5. Limiting values ...continued
In accordance with the Absolute Maximum Rating System (IEC 60134).

Symbol	Parameter	Conditions	Min	Max	Unit
I_C	collector current (DC)	continuous	[1] -	-0.75	A
		continuous	[2] -	-1	A
		continuous	[3] -	-1.3	A
		continuous; $T_s \leq 55\text{ °C}$	[4] -	-2	A
I_{CM}	peak collector current		-	-3	A
I_{BM}	peak base current		-	-1	A
P_{tot}	total power dissipation	$T_{amb} \leq 25\text{ °C}$	[1] -	295	mW
		$T_{amb} \leq 25\text{ °C}$	[2] -	400	mW
		$T_{amb} \leq 25\text{ °C}$	[3] -	500	mW
		$T_s \leq 55\text{ °C}$	[4] -	1000	mW
T_j	junction temperature		-	150	°C
Schottky barrier rectifier					
V_R	continuous reverse voltage		-	40	V
I_F	continuous forward current		-	1	A
I_{FRM}	repetitive peak forward current	$t_p \leq 1\text{ ms}; \delta \leq 0.5$	-	3.5	A
I_{FSM}	non-repetitive peak forward current	$t = 8\text{ ms};$ square wave	-	10	A
P_{tot}	total power dissipation	$T_{amb} \leq 25\text{ °C}$	[1] -	295	mW
		$T_{amb} \leq 25\text{ °C}$	[2] -	400	mW
		$T_{amb} \leq 25\text{ °C}$	[3] -	500	mW
		$T_s \leq 55\text{ °C}$	[4] -	1000	mW
T_j	junction temperature		[2] -	150	°C
Combined device					
P_{tot}	total power dissipation	$T_{amb} \leq 25\text{ °C}$	[2] -	600	mW
T_{stg}	storage temperature		-65	+150	°C
T_{amb}	ambient temperature		[2] -65	+150	°C

- [1] Mounted on a FR4 printed-circuit board, single-sided copper, tin-plated, standard footprint.
 [2] Device mounted on a printed-circuit board, single-sided copper, tin-plated, 1 cm² mounting pad for both collector and cathode.
 [3] Mounted on a ceramic printed-circuit board, single-sided copper, tin-plated, standard footprint.
 [4] Soldering point of collector or cathode tab.

6. Thermal characteristics

Table 6. Thermal characteristics^[1]

Symbol	Parameter	Conditions	Min	Typ	Max	Unit
Single device						
$R_{th(j-s)}$	thermal resistance from junction to soldering point	in free air	[2] -	-	95	K/W
$R_{th(j-a)}$	thermal resistance from junction to ambient	in free air	[3] -	-	250	K/W
			[4] -	-	315	K/W
			[5] -	-	425	K/W
Combined device						
$R_{th(j-a)}$	thermal resistance from junction to ambient	in free air	[3] -	-	208	K/W

[1] For Schottky barrier rectifiers thermal run-away has to be considered, as in some applications the reverse power losses P_R are a significant part of the total power losses. Nomograms for determining the reverse power losses P_R and $I_{F(AV)}$ rating will be available on request.

[2] Soldering point of collector or cathode tab.

[3] Mounted on a ceramic printed-circuit board, single-sided copper, tin-plated, standard footprint.

[4] Device mounted on a printed-circuit board, single-sided copper, tin-plated, 1cm² mounting pad for both collector and cathode tab.

[5] Mounted on a FR4 printed-circuit board, single-sided copper, tin-plated, standard footprint.

7. Characteristics

Table 7. Characteristics
T_{amb} = 25 °C unless otherwise specified

Symbol	Parameter	Conditions	Min	Typ	Max	Unit
PNP transistor						
I _{CBO}	collector-base cut-off current	V _{CB} = -40 V; I _E = 0 A	-	-	-100	nA
		V _{CB} = -40 V; I _E = 0 A; T _j = 150 °C	-	-	-50	μA
I _{CEO}	collector-emitter cut-off current	V _{CE} = -30 V; I _B = 0 A	-	-	-100	nA
I _{EBO}	emitter-base cut-off current	V _{EB} = -5 V; I _C = 0 A	-	-	-100	nA
h _{FE}	DC current gain	V _{CE} = -5 V; I _C = -1 mA	300	-	-	
		V _{CE} = -5 V; I _C = -100 mA	300	-	-	
		V _{CE} = -5 V; I _C = -500 mA	250	-	900	
		V _{CE} = -5 V; I _C = -1 A	160	-	-	
		V _{CE} = -5 V; I _C = -2 A	[1] 50	-	-	
V _{CEsat}	collector-emitter saturation voltage	I _C = -100 mA; I _B = -1 mA	-	-	-120	mV
		I _C = -500 mA; I _B = -50 mA	-	-	-145	mV
		I _C = -1 A; I _B = -100 mA	-	-	-260	mV
		I _C = -2 A; I _B = -200 mA	-	-	-530	mV
R _{CEsat}	equivalent on-resistance	I _C = -1 A; I _B = -100 mA	[1] -	180	280	mΩ
V _{BEsat}	base-emitter saturation voltage	I _C = -1 A; I _B = -100 mA	[1] -	-	-1.1	V
V _{BEon}	base-emitter turn-on voltage	V _{CE} = -5 V; I _C = -1 A	[1] -	-	-1.0	V
f _T	transition frequency	V _{CE} = -10 V; I _C = -50 mA; f = 100 MHz	150	-	-	MHz
C _c	collector capacitance	V _{CB} = -10 V; I _E = I _e = 0 A; f = 1 MHz	-	-	10	pF
Schottky barrier rectifier						
V _F	continuous forward voltage	see Figure 1				
		I _F = 0.1 mA	[1] -	95	130	mV
		I _F = 1 mA	[1] -	155	210	mV
		I _F = 10 mA	[1] -	220	270	mV
		I _F = 100 mA	[1] -	295	350	mV
		I _F = 1000 mA	[1] -	540	640	mV
I _R	reverse current	see Figure 2				
		V _R = 10 V	[1] -	7	20	μA
		V _R = 40 V	[1] -	30	100	μA
C _d	diode capacitance	V _R = 1 V; f = 1 MHz; see Figure 3	-	43	48	pF

[1] Pulse test: t_p ≤ 300 μs; δ ≤ 0.02

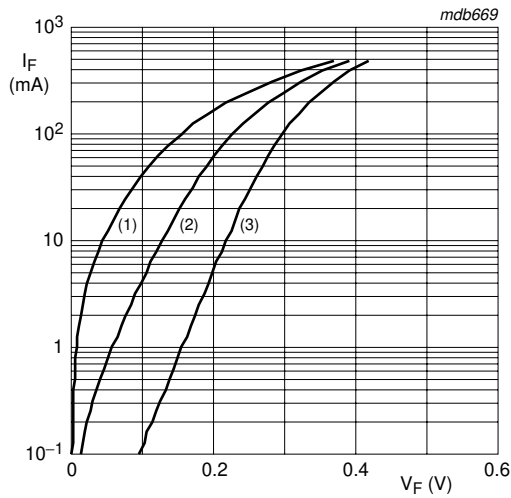

Schottky barrier rectifier

- (1) $T_{amb} = 150\text{ °C}$
- (2) $T_{amb} = 85\text{ °C}$
- (3) $T_{amb} = 25\text{ °C}$

Fig 1. Forward current as a function of forward voltage; typical values

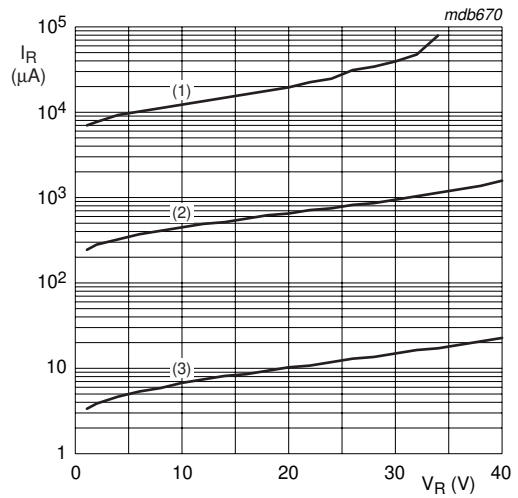

Schottky barrier rectifier

- (1) $T_{amb} = 150\text{ °C}$
- (2) $T_{amb} = 85\text{ °C}$
- (3) $T_{amb} = 25\text{ °C}$

Fig 2. Reverse current as a function of reverse voltage; typical values

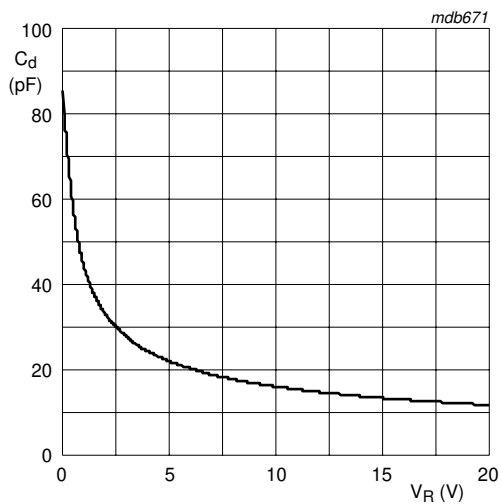

Schottky barrier rectifier;

$T_{amb} = 25\text{ °C}; f = 1\text{ MHz}$

Fig 3. Diode capacitance as a function of reverse voltage; typical values

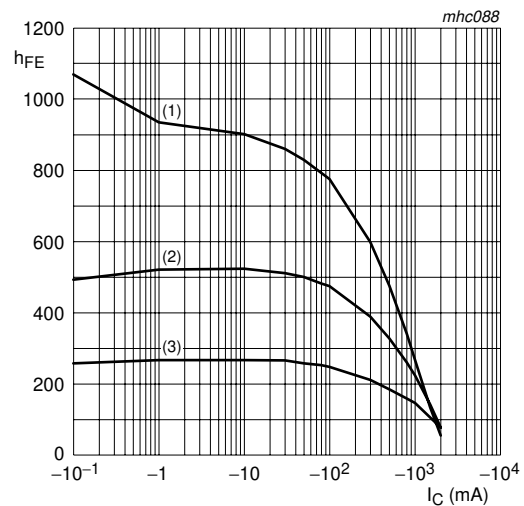

PNP transistor; $V_{CE} = -5\text{ V}$

- (1) $T_{amb} = 150\text{ °C}$
- (2) $T_{amb} = 25\text{ °C}$
- (3) $T_{amb} = -55\text{ °C}$

Fig 4. DC current gain as a function of collector current; typical values

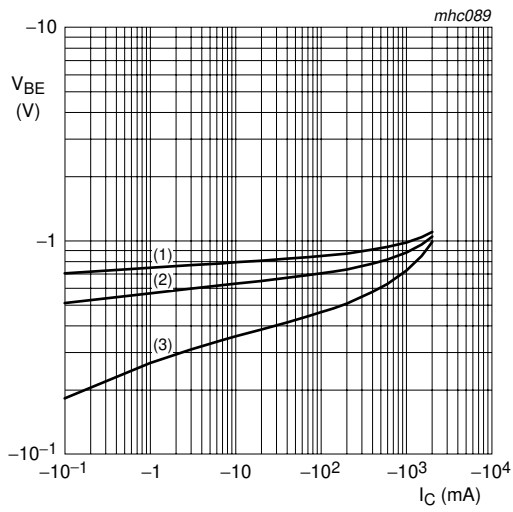

PNP transistor; $V_{CE} = -5\text{ V}$

- (1) $T_{amb} = -55\text{ }^{\circ}\text{C}$
- (2) $T_{amb} = 25\text{ }^{\circ}\text{C}$
- (3) $T_{amb} = 150\text{ }^{\circ}\text{C}$

Fig 5. Base-emitter voltage as a function of collector current; typical values

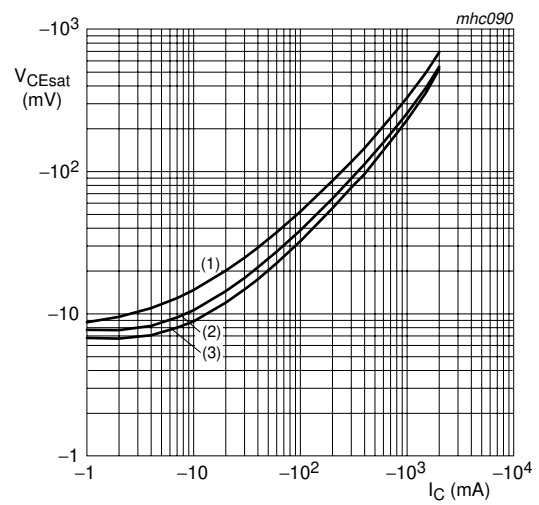

PNP transistor; $I_C/I_B = 10$

- (1) $T_{amb} = 150\text{ }^{\circ}\text{C}$
- (2) $T_{amb} = 25\text{ }^{\circ}\text{C}$
- (3) $T_{amb} = -55\text{ }^{\circ}\text{C}$

Fig 6. Collector-emitter saturation voltage as a function of collector current; typical values

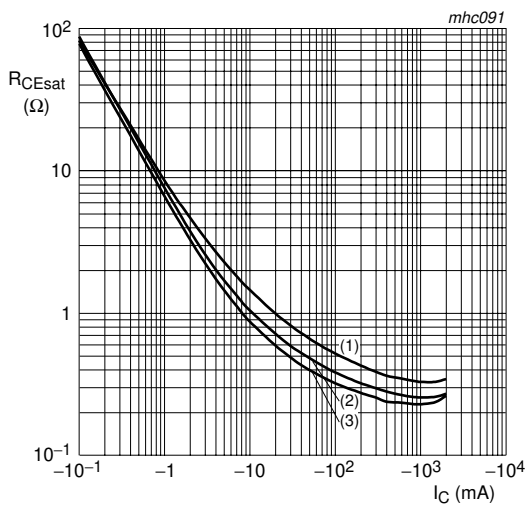

PNP transistor; $I_C/I_B = 10$

- (1) $T_{amb} = 150\text{ }^{\circ}\text{C}$
- (2) $T_{amb} = 25\text{ }^{\circ}\text{C}$
- (3) $T_{amb} = -55\text{ }^{\circ}\text{C}$

Fig 7. Equivalent on-resistance as a function of collector current; typical values

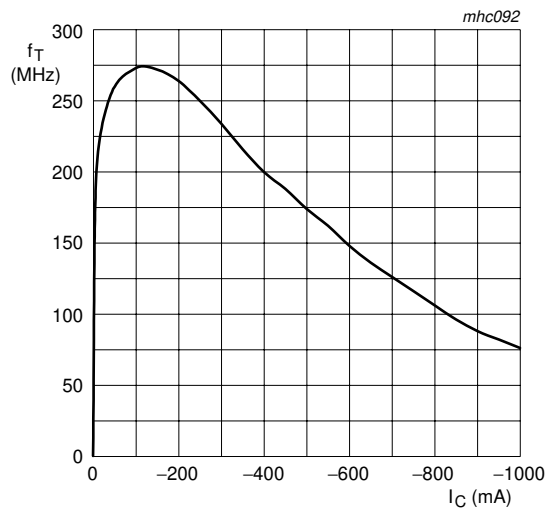

PNP transistor; $V_{CE} = -10\text{ V}$

Fig 8. Transition frequency as a function of collector current

8. Application information

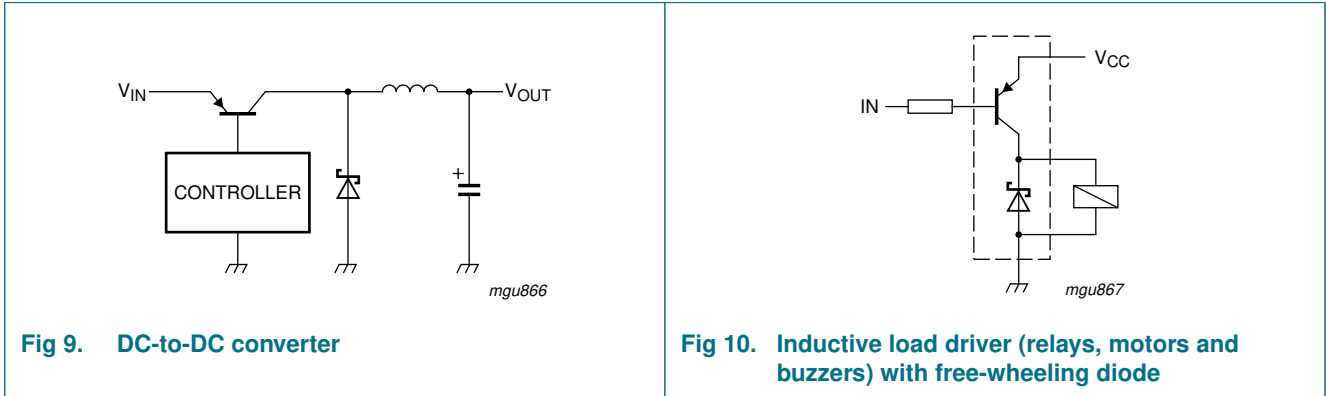

9. Package outline

Plastic surface-mounted package (TSOP6); 6 leads

SOT457

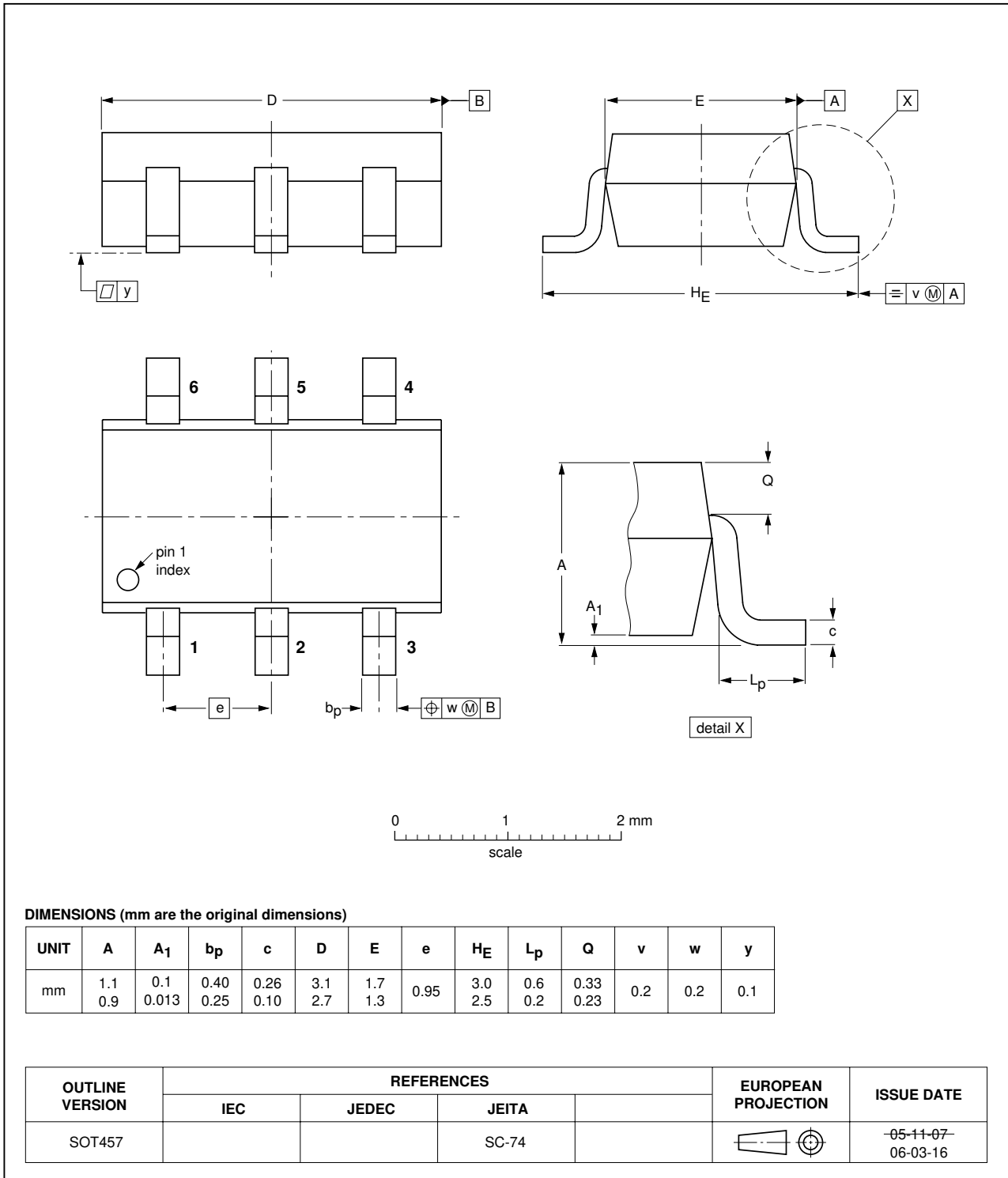

Fig 11. Package outline SOT457 (SC-74)

10. Packing information

Table 8. Packing methods

The indicated -xxx are the last three digits of the 12NC ordering code.^[1]

Type number	Package	Description	Packing quantity	
			3000	10000
PMEM4020APD	SOT457	4 mm pitch, 8 mm tape and reel; T1	-115	-135
		4 mm pitch, 8 mm tape and reel; T2	-125	-165

[1] For further information and the availability of packing methods, see [Section 13](#).

11. Revision history

Table 9. Revision history

Document ID	Release date	Data sheet status	Change notice	Supersedes
PMEM4020APD_2	20090831	Product data sheet	-	PMEM4020APD_1
Modifications:	<ul style="list-style-type: none">• This data sheet was changed to reflect the new company name NXP Semiconductors, including new legal definitions and disclaimers. No changes were made to the technical content.• Table 2 “Discrete pinning”: amended• Figure 11 “Package outline SOT457 (SC-74)”: updated			
PMEM4020APD_1	20041004	Product data sheet	-	-

12. Legal information

12.1 Data sheet status

Document status ^{[1][2]}	Product status ^[3]	Definition
Objective [short] data sheet	Development	This document contains data from the objective specification for product development.
Preliminary [short] data sheet	Qualification	This document contains data from the preliminary specification.
Product [short] data sheet	Production	This document contains the product specification.

[1] Please consult the most recently issued document before initiating or completing a design.

[2] The term 'short data sheet' is explained in section "Definitions".

[3] The product status of device(s) described in this document may have changed since this document was published and may differ in case of multiple devices. The latest product status information is available on the Internet at URL <http://www.nxp.com>.

12.2 Definitions

Draft — The document is a draft version only. The content is still under internal review and subject to formal approval, which may result in modifications or additions. NXP Semiconductors does not give any representations or warranties as to the accuracy or completeness of information included herein and shall have no liability for the consequences of use of such information.

Short data sheet — A short data sheet is an extract from a full data sheet with the same product type number(s) and title. A short data sheet is intended for quick reference only and should not be relied upon to contain detailed and full information. For detailed and full information see the relevant full data sheet, which is available on request via the local NXP Semiconductors sales office. In case of any inconsistency or conflict with the short data sheet, the full data sheet shall prevail.

12.3 Disclaimers

General — Information in this document is believed to be accurate and reliable. However, NXP Semiconductors does not give any representations or warranties, expressed or implied, as to the accuracy or completeness of such information and shall have no liability for the consequences of use of such information.

Right to make changes — NXP Semiconductors reserves the right to make changes to information published in this document, including without limitation specifications and product descriptions, at any time and without notice. This document supersedes and replaces all information supplied prior to the publication hereof.

Suitability for use — NXP Semiconductors products are not designed, authorized or warranted to be suitable for use in medical, military, aircraft, space or life support equipment, nor in applications where failure or malfunction of an NXP Semiconductors product can reasonably be expected to result in personal injury, death or severe property or environmental

damage. NXP Semiconductors accepts no liability for inclusion and/or use of NXP Semiconductors products in such equipment or applications and therefore such inclusion and/or use is at the customer's own risk.

Applications — Applications that are described herein for any of these products are for illustrative purposes only. NXP Semiconductors makes no representation or warranty that such applications will be suitable for the specified use without further testing or modification.

Limiting values — Stress above one or more limiting values (as defined in the Absolute Maximum Ratings System of IEC 60134) may cause permanent damage to the device. Limiting values are stress ratings only and operation of the device at these or any other conditions above those given in the Characteristics sections of this document is not implied. Exposure to limiting values for extended periods may affect device reliability.

Terms and conditions of sale — NXP Semiconductors products are sold subject to the general terms and conditions of commercial sale, as published at <http://www.nxp.com/profile/terms>, including those pertaining to warranty, intellectual property rights infringement and limitation of liability, unless explicitly otherwise agreed to in writing by NXP Semiconductors. In case of any inconsistency or conflict between information in this document and such terms and conditions, the latter will prevail.

No offer to sell or license — Nothing in this document may be interpreted or construed as an offer to sell products that is open for acceptance or the grant, conveyance or implication of any license under any copyrights, patents or other industrial or intellectual property rights.

Export control — This document as well as the item(s) described herein may be subject to export control regulations. Export might require a prior authorization from national authorities.

Quick reference data — The Quick reference data is an extract of the product data given in the Limiting values and Characteristics sections of this document, and as such is not complete, exhaustive or legally binding.

12.4 Trademarks

Notice: All referenced brands, product names, service names and trademarks are the property of their respective owners.

13. Contact information

For more information, please visit: <http://www.nxp.com>

For sales office addresses, please send an email to: salesaddresses@nxp.com

14. Contents

1 Product profile 1

1.1 General description 1

1.2 Features 1

1.3 Applications 1

1.4 Quick reference data 1

2 Pinning information 2

3 Ordering information 2

4 Marking 2

5 Limiting values 2

6 Thermal characteristics 4

7 Characteristics 5

8 Application information 8

9 Package outline 9

10 Packing information 10

11 Revision history 11

12 Legal information 12

12.1 Data sheet status 12

12.2 Definitions 12

12.3 Disclaimers 12

12.4 Trademarks 12

13 Contact information 12

14 Contents 13

Please be aware that important notices concerning this document and the product(s) described herein, have been included in section 'Legal information'.



© NXP B.V. 2009.

All rights reserved.

For more information, please visit: <http://www.nxp.com>

For sales office addresses, please send an email to: salesaddresses@nxp.com

Date of release: 31 August 2009

Document identifier: PMEM4020APD_2