



Chipsmall Limited consists of a professional team with an average of over 10 year of expertise in the distribution of electronic components. Based in Hongkong, we have already established firm and mutual-benefit business relationships with customers from,Europe,America and south Asia,supplying obsolete and hard-to-find components to meet their specific needs.

With the principle of “Quality Parts,Customers Priority,Honest Operation,and Considerate Service”,our business mainly focus on the distribution of electronic components. Line cards we deal with include Microchip,ALPS,ROHM,Xilinx,Pulse,ON,Everlight and Freescale. Main products comprise IC,Modules,Potentiometer,IC Socket,Relay,Connector.Our parts cover such applications as commercial,industrial, and automotives areas.

We are looking forward to setting up business relationship with you and hope to provide you with the best service and solution. Let us make a better world for our industry!



Contact us

Tel: +86-755-8981 8866 Fax: +86-755-8427 6832

Email & Skype: info@chipsmall.com Web: www.chipsmall.com

Address: A1208, Overseas Decoration Building, #122 Zhenhua RD., Futian, Shenzhen, China





Piezoelectric MEMS Two Microphone Slider Evaluation Board

Data Sheet

PMM-3738-VM1000-EB-2-R

PUI Audio, featuring Vesper's exclusive technology, presents the PMM-3738-VM1000-EB-2-R two-microphone slider evaluation board.

This evaluation board is designed to quickly allow users to connect two PMM-3738-VM1000-R microphones directly into a Plug-In Power, two-wire microphone interface. The spacing of the microphones can be varied from 10mm up to 120mm, for stereo recording or for creating a microphone array.



Evaluation Board Features:

- Two PMM-3738-VM1000-R piezoelectric MEMS microphones on moveable PCBs
- Slider stand with mounting flanges and an integrated ruler for setting microphone spacing
- Built-in two-wire conversion circuits and three-pole 3.5mm plug for quick connection

PMM-3738-VM1000-R Features:

- Very-low microphone noise floor and high dynamic range
- Stable performance in all conditions; dust and water resistant to IP57
- Stiction immunity and ultra-fast startup <math><100\mu\text{S}</math>

Setup

The built-in 3.5mm plug is wired to each microphone for left and right channel recording and connects directly to any system with a Plug-In Power interface, such as found on the Conexant CX20921 AVS two-mic evaluation system and the Zoom H1 Audio Recorder.

Microphone Slider Operation

Each mini microphone PCB assembly is a unique combination of flex and solid PCBs to hold the microphones in-place when in the mic slider stand channel, while allowing the user to easily adjust the microphone spacing distance.

On each of the mini PCBs, there are three solid PCBs connected together by two flex circuits. The two outer solid PCBs act as adjustment wings. The center solid PCB is where the microphone is mounted.

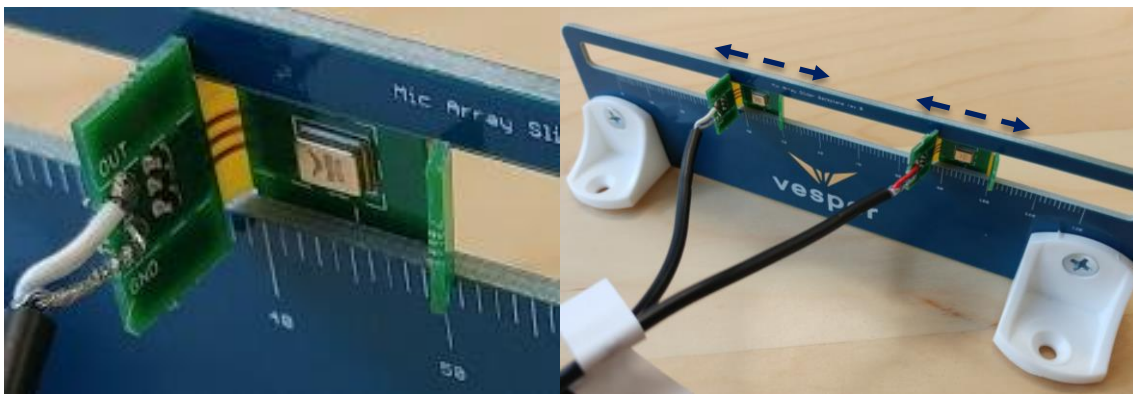

Solid and Flex circuits

Intended slider operation

To move the mics in the slider channel the user grabs each mic by the PCB wings on either side of the mic. By pinching the tabs together, the user reduces the tension between the boards which holds it in place in the slider channel, allowing it to slide side-to-side. The user should not try to move the mini PCB assemblies by pulling on only one wing, as the tension will not be reduced and the flex circuit could tear with excessive strain.

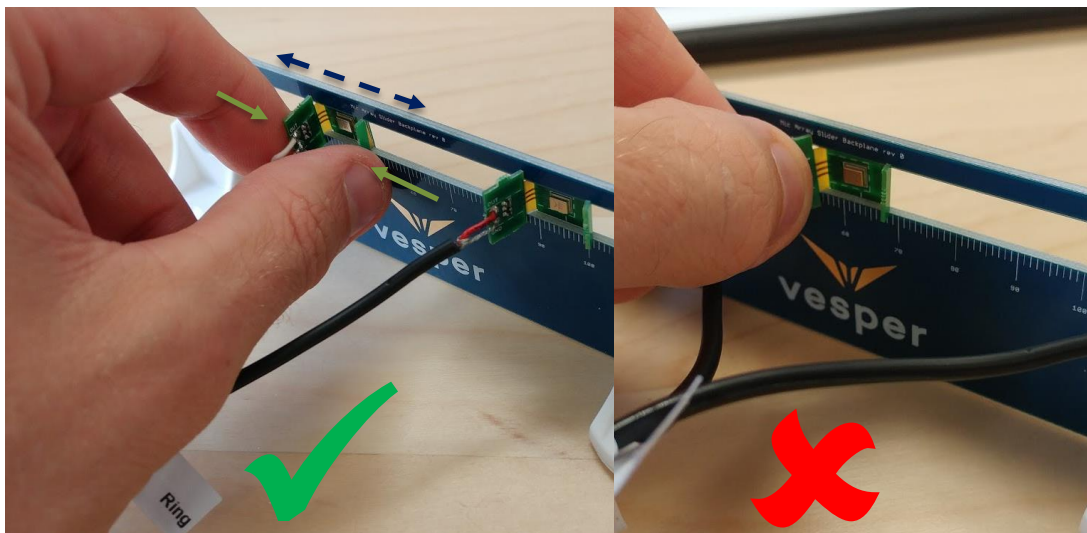

Use of Microphones without Slider Stand

After characterizing the performance of the microphones at a given distance, a user may wish to use them for prototyping in a housing or industrial design.

The microphone mini PCB assemblies may be removed from the slider stand channel by gently twisting the smaller PCB wing to fit between the upper and lower rails of the channel. Once the smaller PCB tab is free of the channel rails, the rest of the mini PCB assembly can be rotated and removed from the slider channel.

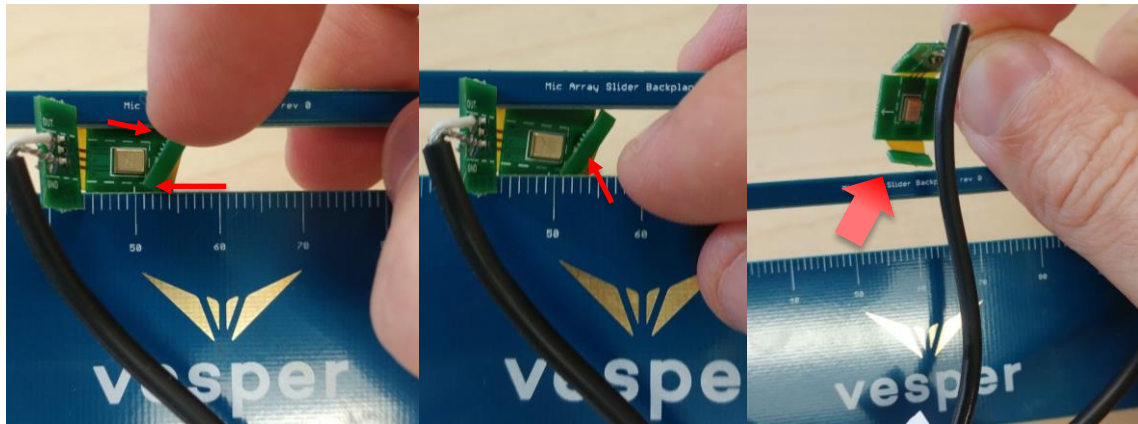

PMM-3738-VM1000-EB-2-R Schematic and Notes

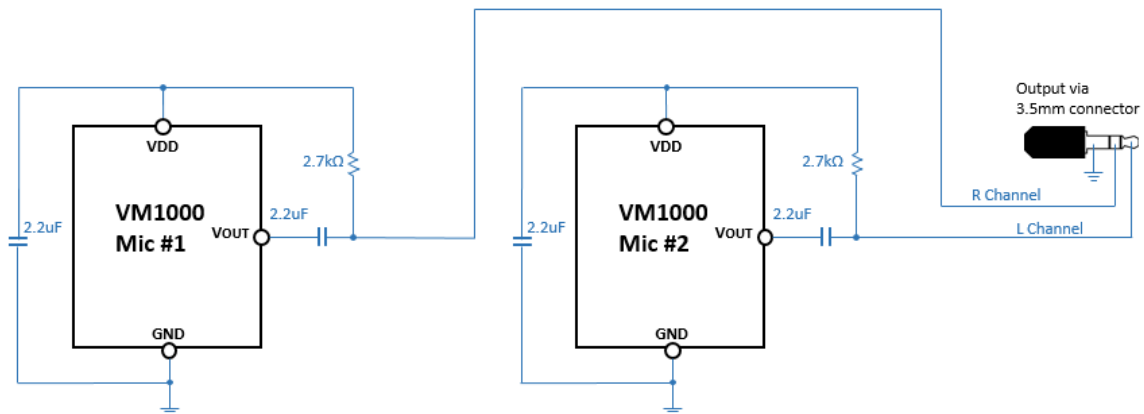

The Plug-In Power bias should be validated to be within -0.3 to +3.6 VDC prior to connecting the PMM-3738-VM1000-EB-2-R to a system.

PMM-3738-VM1000-R Specifications

All specifications are at 25°C, $V_{Supply} = 1.8\text{ V}$ unless otherwise noted.

Parameter	Symbol	Conditions	Min.	Typ.	Max.	Units
Acoustic Specifications						
Sensitivity		1 kHz, 94 dB SPL	-41	-38	-35	dBV
Signal-to-Noise Ratio	SNR	94 dB SPL at 1 kHz signal, 20Hz to 20kHz, A-weighted Noise		62		dB(A)
Signal-to-Noise Ratio Voice Band	SNR	94 dB SPL at 1 kHz signal, 20Hz to 8kHz, A-weighted Noise		64		dB(A)
Total Harmonic Distortion	THD	94 dB SPL		0.1		%
Acoustic Overload Point	AOP	10.0% THD		125		dB SPL
Roll Off Frequency		-3db at 1KHz		85		Hz
Directivity			Omni			
Polarity		Increase in sound pressure	Increase in output voltage			
Electrical Specifications						
Supply Voltage			1.6	1.8	3.6	V
Supply Current		$V_{Supply} \leq 3.6\text{ V}$ (TBR)		165		μA
Power Supply Rejection Ratio	PSRR	VDD = 1.8, 1kHz, 200mV _{PP} Sine wave		55		dB
Power Supply Rejection	PSR	VDD = 1.8, 217Hz, 100mV _{PP} square wave, 20 Hz – 20kHz, A-weighted		-85		dB(A)
Output Impedance	Z _{OUT}			400		Ω
Output DC Offset				0.8		V
Startup Time				100		μS

Absolute Maximum Ratings

Parameter	Rating	Units
Supply Voltage	-0.3 to +3.6	V
Sound Pressure Level	160	dB re 20 μ Pa
Operating Temperature Range	-40 to +85	$^{\circ}$ C
Storage Temperature Range	-55 to +150	$^{\circ}$ C
Mechanical Shock	10,000g per IEC 60028-2-27:2008	
Vibration	Per MIL-STD 883E, 2007.2	

Typical Performance Characteristics

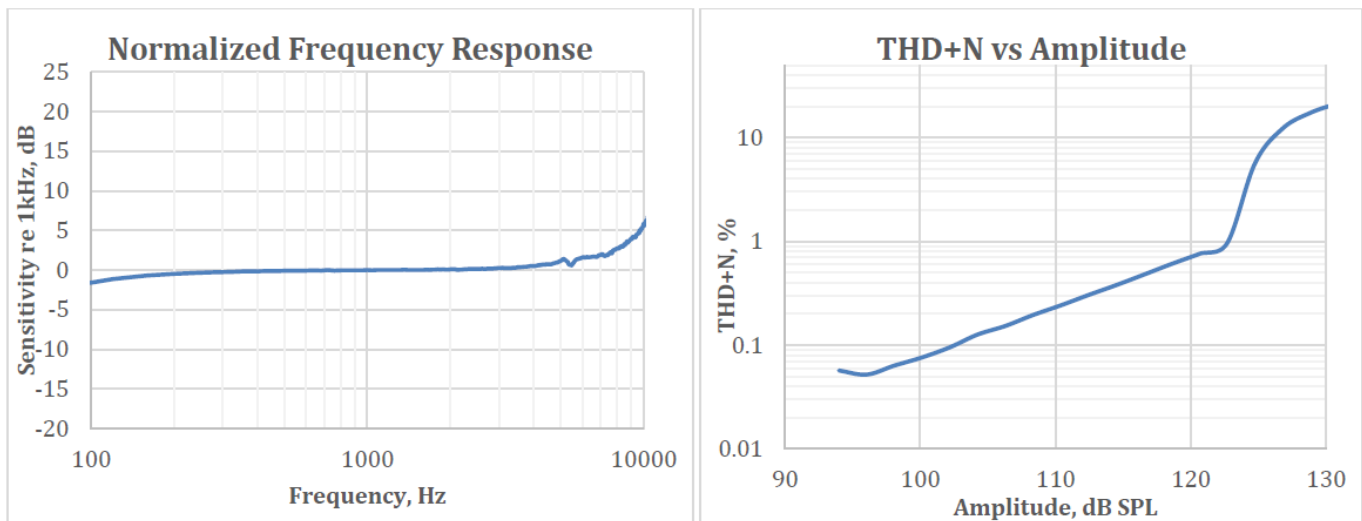

Environmental Robustness

IP adherence is evaluated by 1 kHz Sensitivity spec post stress

Ingress Protection Type	Description
Dust Resistance	IP5X;
Water Immersion	IPX7; 2 hours drying time, normal dry environment

Reliability Specifications

Stress Test	Description
Temperature Cycling Test	-40°C to +125°C, 850 cycles
High Temperature Operating Life	+125°C, 1000 hours, biased
High Temperature Storage	+125°C, 1000 hours, unbiased
Temperature Humidity Bias	+85°C, 85% RH, 1000 hours, biased
Reflow	3 reflow cycles with peak temperature of +260°C
ESD-HBM	3 discharges, all pins, ± 2kV
ESD-CDM	3 discharges, all pins, ± 800V
ESD-LID/GND	3 discharges to lid, ± 8kV
ESD-MM	3 discharges, all pins, ± 200V
ESD-Air Discharge	3 discharges, ± 15kV

Handling Instructions

The Piezo MEMS microphone is very robust to harsh environments such as dust and moisture. However, to avoid mechanical damage to the microphone, we recommend using appropriate handling procedures when manually handling the parts. The following guidelines will help to avoid damage:

- Do not apply a vacuum to the bottom side of the microphone. A vacuum pen may be used with care on the top side only.
- Do not apply very high air pressure over the sound port hole.
- Do not insert any large particles or objects in the sound port hole. The microphone is resistant to small particles per IP5X specification.
- Do not expose the sound port to harsh chemicals.

Dimensions and Pin Layout

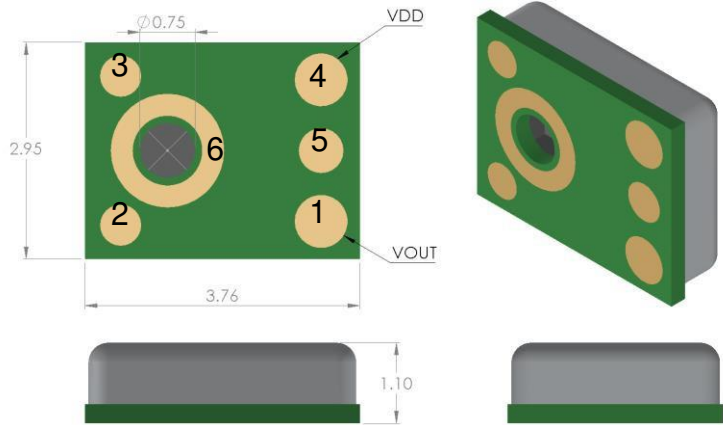

Pin Number	Pin Name	Description
1	V _{OUT}	Analog Output Voltage
2	GND	Ground
3	GND	Ground
4	V _{DD}	Power Supply
5	GND	Ground
6	GND	Ground

PMM-3738-VM1000-R PCB Design and Land Pattern Layout

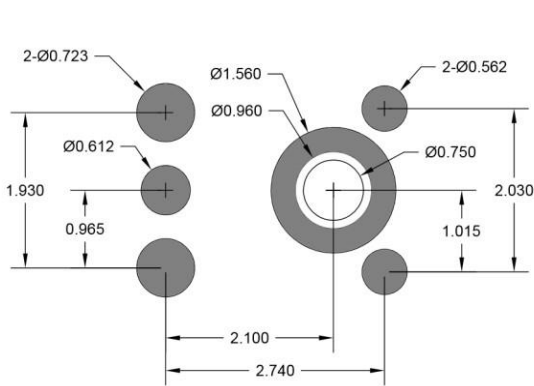

PCB Land Pattern

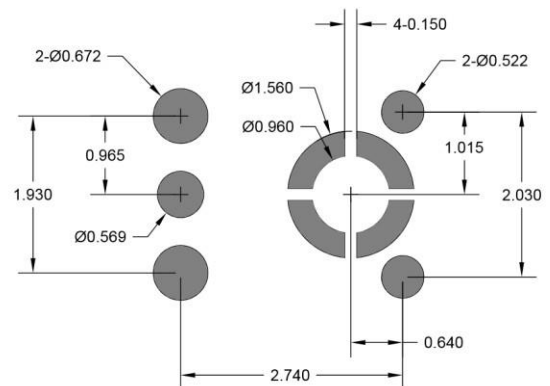

Solder Stencil Pattern

Specifications Revisions

Revision	Description	Date
-	Released from Engineering	9/14/2017

Note:

1. All dimensions are in millimeters.
2. Specifications subject to change or withdrawal without notice.
3. This part is RoHS 2011/65/EU Compliant.