



Chipsmall Limited consists of a professional team with an average of over 10 year of expertise in the distribution of electronic components. Based in Hongkong, we have already established firm and mutual-benefit business relationships with customers from,Europe,America and south Asia,supplying obsolete and hard-to-find components to meet their specific needs.

With the principle of “Quality Parts,Customers Priority,Honest Operation,and Considerate Service”,our business mainly focus on the distribution of electronic components. Line cards we deal with include Microchip,ALPS,ROHM,Xilinx,Pulse,ON,Everlight and Freescale. Main products comprise IC,Modules,Potentiometer,IC Socket,Relay,Connector.Our parts cover such applications as commercial,industrial, and automotives areas.

We are looking forward to setting up business relationship with you and hope to provide you with the best service and solution. Let us make a better world for our industry!



## Contact us

Tel: +86-755-8981 8866 Fax: +86-755-8427 6832

Email & Skype: info@chipsmall.com Web: www.chipsmall.com

Address: A1208, Overseas Decoration Building, #122 Zhenhua RD., Futian, Shenzhen, China



THIS COPY IS PROVIDED ON A RESTRICTED BASIS AND IS NOT TO BE USED IN ANY WAY DETRIMENTAL TO THE INTERESTS OF PANDUIT CORP.

PANDUIT PART #	STUD SIZE		DIMENSIONS in. [mm]				
	ENGLISH	METRIC	L ± .03 [0,8]	W ± .01 [0,3]	C ± .02 [0,5]	M ± .03 [0,8]	H ± .01 [0,3]
PMNF1-3F*	--	M3	.83 [21,1]	.23 [5,8]	.20 [5,1]	.69 [17,5]	.13 [3,3]
PNF18-6F	#6	M3,5	.80 [20,3]	.30 [7,6]	.22 [5,6]	.66 [16,8]	.15 [3,8]
PNF18-8F	#8	M4	.86 [21,8]	.31 [7,9]	.25 [6,4]	.69 [17,5]	.17 [4,3]
PNF18-10F	#10	--	.87 [22,1]	.34 [8,6]	.26 [6,6]	.71 [18,0]	.20 [5,1]
PMNF1-5F*	--	M5	.90 [22,9]	.35 [8,9]	.25 [6,4]	.74 [18,8]	.21 [5,3]
PNF18-14F	1/4"	M6	1.05 [26,7]	.44 [11,2]	.35 [8,9]	.80 [20,3]	.27 [6,9]

\* NOT UL LISTED OR CSA CERTIFIED

NOTES:

- USED FOR:
  - #22-18 AWG [0,5-1,0 mm<sup>2</sup>] STRANDED COPPER WIRE
  - 221°F [105°C] MAX. OPERATING TEMPERATURE
  - 600V. MAX. BLDG WIRE (1000 V. MAX. IN SIGNS, FIXTURES & LUMINAIRES)
- INSTALLATION TOOLS:
  - UL APPROVED: CT-100A, CT-1550, CT-1551
  - PANDUIT APPROVED: CT-160, CT-260, CT-400, CT-460, CT-600A (CT-550CH), CT-2500 (CT-2550CH)
- WIRE STRIP LENGTH: 7/32" <sup>1/32</sup> [5,6 <sup>1/32</sup>]
- MATERIAL:
  - STAMPING: .03" [0,8] THK COPPER, TIN PLATED
  - HOUSING: NYLON, RED
  - SLEEVE: BRASS, TIN PLATED
- SEE [www.panduit.com](http://www.panduit.com) FOR PACKAGE QUANTITIES INDICATED BY PART NUMBER SUFFIX
- DIMENSIONS IN BRACKETS ARE METRIC EQUIVALENT

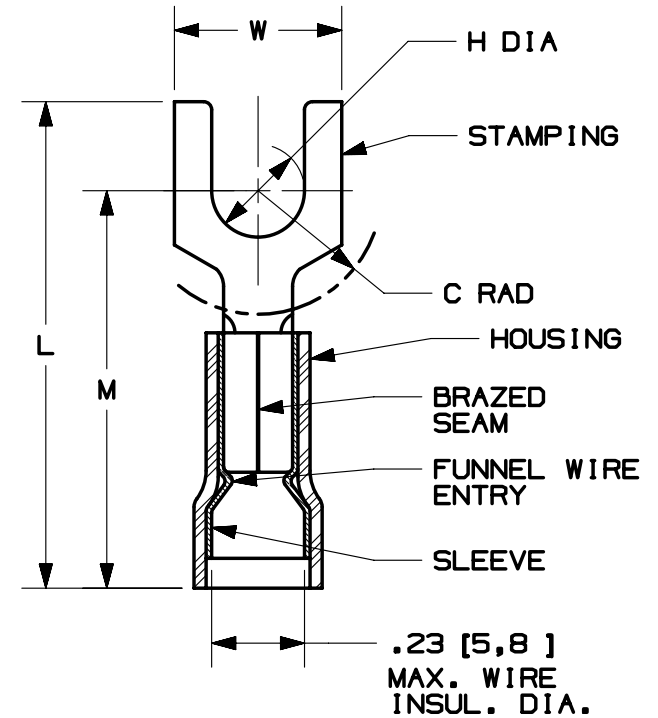

LISTED  
587H  
E52164



CERTIFIED  
LR31212

REV	DATE	BY	CHK	APR	DESCRIPTION	ECN
09	12.12.13	JHNU	JHNU	RGB	REVISED NOTE 2B: CT-550CH WAS CT-520CH, CT-2550CH WAS CT-2525	A41260
08	11.26.13	JHNU	TMR	RGB	INDICATED PART NUMBERS WHICH ARE NOT UL LISTED/CSA CERTIFIED	A41260
07	09.19.12	JBN	LCA	VMB	ADDED METRIC EQUIVALENT. REVISED NOTES. UPDATED TO CURRENT STANDARDS	A41260

TITLE <b>FORK, NYLON (FUNNEL) INSULATED #22-18</b> CUSTOMER DRAWING	
ITEM REVISION NAME N41260BA/09	<b>PANDUIT</b>
DATASET FILE NAME N41260BA_DC/09A	
UNLESS OTHERWISE SPECIFIED, DIMENSIONAL TOLERANCES ARE: IN [mm] .x ± .1 [2.54]    .xxx ± .005 [.13] .xx ± .01 [.25]    ANGLES ± 5°	
THIRD ANGLE PROJECTION	
DRAWING NUMBER: <b>A41260</b>	
DRAWN BY DAW	DATE -
CHK LA	SCALE N.T.S.
SHT 1 OF 1	
SIZE <b>A</b>	

15/0000A/15