



Chipsmall Limited consists of a professional team with an average of over 10 year of expertise in the distribution of electronic components. Based in Hongkong, we have already established firm and mutual-benefit business relationships with customers from,Europe,America and south Asia,supplying obsolete and hard-to-find components to meet their specific needs.

With the principle of "Quality Parts,Customers Priority,Honest Operation,and Considerate Service",our business mainly focus on the distribution of electronic components. Line cards we deal with include Microchip,ALPS,ROHM,Xilinx,Pulse,ON,Everlight and Freescale. Main products comprise IC,Modules,Potentiometer,IC Socket,Relay,Connector.Our parts cover such applications as commercial,industrial, and automotives areas.

We are looking forward to setting up business relationship with you and hope to provide you with the best service and solution. Let us make a better world for our industry!



## Contact us

Tel: +86-755-8981 8866 Fax: +86-755-8427 6832

Email & Skype: info@chipsmall.com Web: www.chipsmall.com

Address: A1208, Overseas Decoration Building, #122 Zhenhua RD., Futian, Shenzhen, China





**TELEDYNE LECROY**  
Everywhereyoulook™

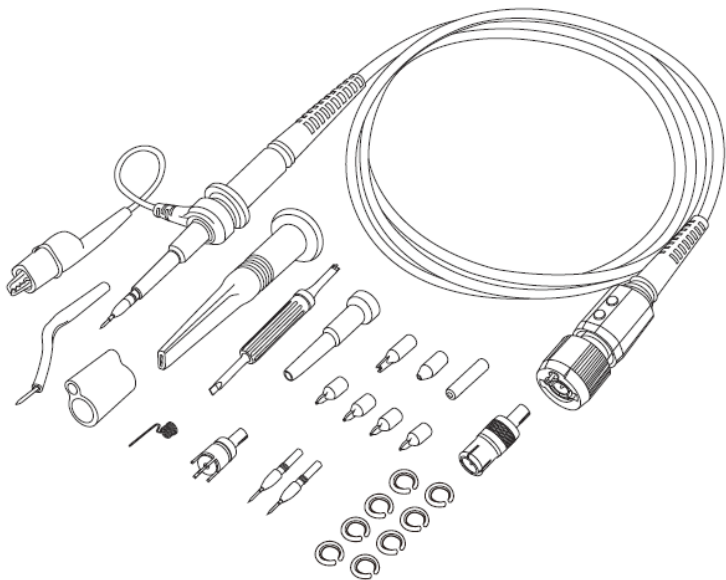

# Operator's Manual

## PP023

### Passive Probe

PP023-1	
PP023-2	



**TELEDYNE LECROY**  
Everywhereyoulook™

700 Chestnut Ridge Road  
Chestnut Ridge, NY, 10977-6499  
Tel: (845) 425-2000, Fax: (845) 578 5985  
teledynelecroy.com

## PP023 Passive Probe Instruction Manual

© 2015 Teledyne LeCroy, Inc. All rights reserved.

Unauthorized duplication of Teledyne LeCroy documentation materials other than for internal sales and distribution purposes is strictly prohibited. However, clients are encouraged to duplicate and distribute Teledyne LeCroy documentation for internal educational purposes.

Teledyne LeCroy is a registered trademark of Teledyne LeCroy, Inc. Other product or brand names are trademarks or requested trademarks of their respective holders. Information in this publication supersedes all earlier versions. Specifications subject to change without notice.



This electronic product is subject to disposal and recycling regulations that vary by country and region. Many countries prohibit the disposal of waste electronic equipment in standard waste receptacles. For more information about proper disposal and recycling of your Teledyne LeCroy product, visit [teledynelecroy.com/recycle](http://teledynelecroy.com/recycle).

925646-00  
May, 2015

## Terms and Symbols

The following symbols appear on the product or in its documentation:



---

<b>DANGER</b>	High Voltage
---------------	--------------

---



---

<b>WARNING</b>	Refer to Manual. Condition or practice could result in injury or loss of life.
----------------	--

---



---

<b>DOUBLE INSULATION</b>
--------------------------

---



---

<b>PROTECTIVE (EARTH) TERMINAL</b>
------------------------------------

---

## Introduction

The Teledyne LeCroy PP023 is a passive high impedance voltage oscilloscope probe designed and calibrated for use with general purpose oscilloscopes having an input impedance of 1 M $\Omega$  and can be compensated for use with instruments having an input capacitance between 10 to 20 pF. It is compatible with oscilloscopes that automatically detect probe attenuation and adjust their readout accordingly.

# PP023 Passive Probe

## Specifications

Model	Attn.	Input Imped.		B/W (MHz)	Rise Time (ps)	Length (m)	Compensation Range (pF)
		R (M $\Omega$ )	C (pF)				
<b>PP023</b>	10x	10	10	500	700	1.3	10 - 20

Attenuation Ratio ..... 10:1  $\pm$  1%

Max. Input Voltage ..... Measurement Category I <sup>1</sup>: 500 Vrms  
1500 V transient overvoltage  
(see voltage derating curve on p. 3)  
Measurement Category II <sup>2</sup>: 400 Vrms

Pollution Degree ..... Pollution Degree 2 <sup>3</sup>

Operating Temperature ..... 0° C to +50° C

Humidity ..... 5% to 95% RH (10° C to 30° C)  
5% to 75% RH (30° C to 40° C)  
5% to 50% RH (above 40° C)  
RH not controlled below 10° C

Operating Altitude ..... 3000 meters maximum



---

To reduce risk of fire or electric shock, do not exceed the voltage or category ratings of the probe.

---

### Definitions (per EN 61010-031)

1) Measurement Category I (CAT I) refers to measurements performed on circuits not directly connected to mains.

2) Measurement Category II (CAT II) refers to measurements performed on circuits directly connected to the low-voltage installation.

3) Pollution Degree 2 refers to an operating environment where normally only dry, non-conductive pollution occurs. Temporary conductivity caused by condensation must be expected.

## PP023 Input Impedance Profile

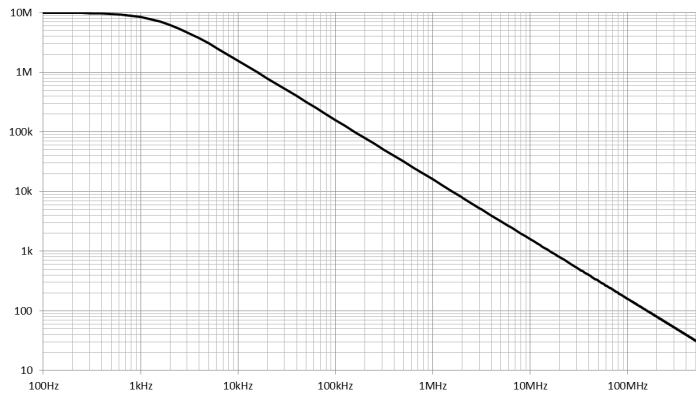

## Voltage vs. Frequency Derating Curve

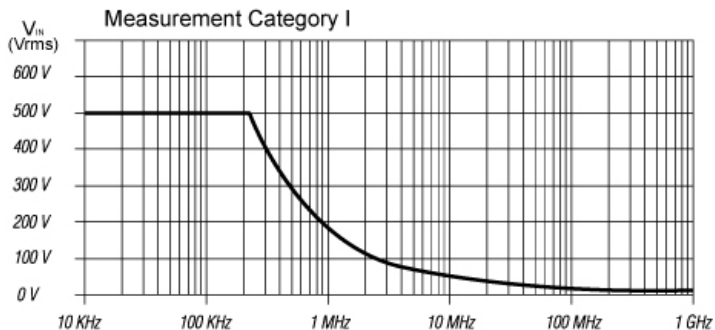

## PP023 Passive Probe

### EC Declaration of Conformity



The probe is marked with this symbol to show compliance was demonstrated to the specifications listed in the Official Journal of the European Communities: Low Voltage Directive 2006/95/EC:

EN 61010-031/A1:2008 Safety requirements for electrical equipment for measurement, control and laboratory use – Part 031: Safety requirements for handheld probe assemblies for electrical measurement and test.

### EU RoHS Compliance

The probe and its accessories conform to the 2011/65/EU RoHS2 Directive, as they have been classified as Industrial Monitoring and Control Equipment (per Article 3, Paragraph 24) and are exempt from RoHS compliance until 22 July 2017 (per Article 4, Paragraph 3).

### General Safety Information



Observe generally accepted safety procedures in addition to those listed here to avoid personal injury or damage to equipment. **The overall safety of any system incorporating this accessory is the responsibility of the assembler of the system.**

**Connect only to grounded instruments.** Use only with compatible Teledyne LeCroy oscilloscopes that have their BNC input connected to an earth ground. Do not connect the probe reference lead to any point which is at a potential other than earth ground.

**Connect and disconnect properly.** Connect probe to the oscilloscope before connecting it to the test circuit. Disconnect the probe input and reference lead from the test circuit before disconnecting from the oscilloscope. Do not connect or disconnect probes while they are connected to a voltage source.

**Do not overload.** Do not apply any potential to the probe leads that exceeds the maximum rating of the probe. **Always comply with the Voltage vs. Frequency Derating Curve.**

**Observe all terminal ratings.** Observe all markings on the oscilloscope before connecting. Consult the oscilloscope product manual for further ratings information.

**Do not remove probe casing.** Touching exposed connections may result in electric shock.

**Use indoors only within operational environment listed.** Do not use in wet or explosive atmospheres. Keep product surfaces clean and dry.

**Handle with care.** Probe tips are extremely sharp and may puncture skin or cause other bodily injury if not handled properly.

**Keep fingers behind the finger guard of probe body and accessories.**

**Do not operate with suspected failures.** Before each use, inspect the probe and accessories for any potential damage such as tears or other defects in the probe body, cable jacket, accessories, etc. If any part is damaged, cease operation immediately and sequester the probe from inadvertent use.

### Cleaning

- Clean only the exterior of the probe, cables, and accessories. Use a soft cotton cloth moistened with a mild detergent and water solution. Do not allow any portion of the probe to be submerged at any time.
- Dry the probe and accessory thoroughly before attempting to make any voltage measurement.
- Do not subject the probe to solvents or solvent fumes as these can cause deterioration of the probe body, cables, and accessories.



## PP023 Passive Probe

### Probe Compensation

Proper compensation of the probe is required to assure amplitude accuracy of the waveform being measured by matching the probe to the oscilloscope's input capacitance. Compensation should be adjusted whenever the probe is connected to or transferred between oscilloscopes.

#### ***Low Frequency***

1. Apply a 1 kHz square wave to the probe or connect to the oscilloscope's calibrator output.
2. Adjust the single LF trimmer located on the PP023 BNC Box until you achieve a flat-topped square wave (see figure below):

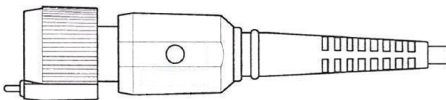

#### ***High Frequency***

1. Apply a 1 MHz square wave to the probe (< 0.7 ns rise-time).
2. Remove the plastic caps from the two, high-frequency trimmers on the PP023 BNC Compensation Box.
3. Adjust HF2 then HF1 until you achieve a flat-topped square wave (see figure below).

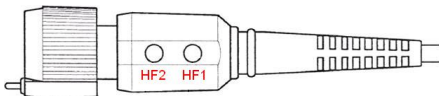

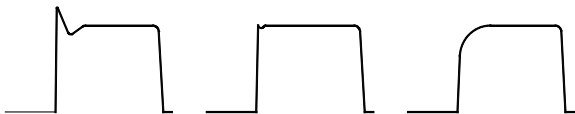

*Over-compensated, correct, and under-compensated waveforms*

## Probe Accessories

### ***Probe Tips***

Both the rigid probe tip and the spring tip can be screwed on to the probe body by hand.



---

Be sure not to overtighten the tips to avoid damaging the threads.

---

### ***Ground Accessories***

The ground lead and the short collar are attached to the probe at the time of shipping. To replace the ground lead with the swivel lead adapter, unscrew the short collar from the probe and remove the ground lead. Replace the short collar to hold the swivel lead adapter in place.

Alternatively, the long collar can be pushed onto the probe body and used in conjunction with the ground spring, BNC adapter or PCB adapter.

## Service

Refer all service to qualified personnel.

For the most complete and up-to-date list of sales and service centers by country, visit [teledynelecroy.com/support/contact](http://teledynelecroy.com/support/contact).

# PP023 Passive Probe

## Replaceable Parts

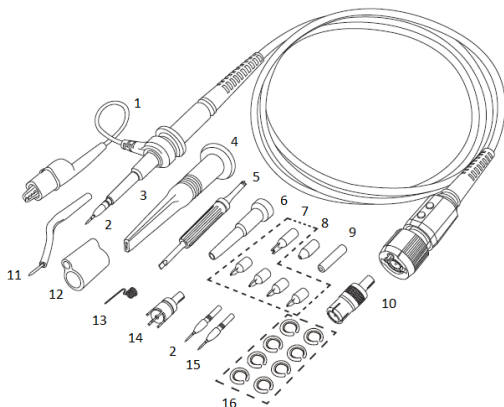

Item	Part Number	Description	QTY
1	PK5-2.5MM-101	Ground Lead with Alligator Clip	1
2	PK5-2.5MM-102	Rigid Probe Tip (1 installed standard)	2
3	PK5-2.5MM-103	Short Collar (installed standard)	1
4	PK5-2.5MM-104	Sprung Hook	1
5	PK5-PK6-001	Trimmer Tool	1
6	PK5-2.5MM-105	Long Collar	1
7	PK5-2.5MM-106	IC Tip Insulators (Black, Brown, Blue, Green, Gray)	5
8	PK5-2.5MM-107	Tip Insulator 2.5mm	1
9	PK5-2.5MM-108	Probe Tip Cover	1
10	PK5-2.5MM-109	BNC Adapter 2.5mm	1
11	PK5-2.5MM-110	Swivel Ground Lead	1
12	PK5-2.5MM-111	Swivel Ground Lead Adapter	1
13	PK5-2.5MM-112	Ground Spring	1
14	PK5-2.5MM-113	PCB Adapter	1
15	PK5-2.5MM-114	Spring Tip	1
16	PK5-PK6-002	Color Coding Rings (2 ea. yellow, red, green, blue)	8

Standard Accessory Replacement Kit part number is **PKIT5-2.5MM-101**.

## Warranty

**NOTE:** THE WARRANTY BELOW REPLACES ALL OTHER WARRANTIES, EXPRESSED OR IMPLIED, INCLUDING BUT NOT LIMITED TO ANY IMPLIED WARRANTY OF MERCHANTABILITY, FITNESS, OR ADEQUACY FOR ANY PARTICULAR PURPOSE OR USE. TELEDYNE LECROY SHALL NOT BE LIABLE FOR ANY SPECIAL, INCIDENTAL, OR CONSEQUENTIAL DAMAGES, WHETHER IN CONTRACT OR OTHERWISE. THE CUSTOMER IS RESPONSIBLE FOR THE TRANSPORTATION AND INSURANCE CHARGES FOR THE RETURN OF PRODUCTS TO THE SERVICE FACILITY. TELEDYNE LECROY WILL RETURN ALL PRODUCTS UNDER WARRANTY WITH TRANSPORT PREPAID.

Teledyne LeCroy warrants this oscilloscope accessory for normal use and operation within specification for a period of one year from the date of shipment. Spare parts, replacement parts and repairs are warranted for 90 days.

In exercising its warranty, Teledyne LeCroy, at its option, will either repair or replace any assembly returned within the warranty period to the Customer Service Department of an authorized service center. However, this will be done only if the product is determined by Teledyne LeCroy's examination to be defective because of workmanship or materials, and the defect is not caused by misuse, neglect, accident, abnormal conditions of operation, or, damaged by attempted repair or modifications by a non-authorized service facility.

The customer will be responsible for the transportation and insurance charges for the return of products to the service facility. Teledyne LeCroy will return all products under warranty with transportation charges prepaid.

This warranty replaces all other warranties, expressed or implied, including, but not limited to, any implied warranty of merchantability, fitness, or adequacy for any particular purposes or use. Teledyne LeCroy shall not be liable for any special, incidental, or consequential damages, whether in contract or otherwise.

925646-00  
May, 2015



700 Chestnut Ridge Road  
Chestnut Ridge, NY 10977  
USA

[www.teledynelecroy.com](http://www.teledynelecroy.com)