



Chipsmall Limited consists of a professional team with an average of over 10 year of expertise in the distribution of electronic components. Based in Hongkong, we have already established firm and mutual-benefit business relationships with customers from,Europe,America and south Asia,supplying obsolete and hard-to-find components to meet their specific needs.

With the principle of “Quality Parts,Customers Priority,Honest Operation,and Considerate Service”,our business mainly focus on the distribution of electronic components. Line cards we deal with include Microchip,ALPS,ROHM,Xilinx,Pulse,ON,Everlight and Freescale. Main products comprise IC,Modules,Potentiometer,IC Socket,Relay,Connector.Our parts cover such applications as commercial,industrial, and automotives areas.

We are looking forward to setting up business relationship with you and hope to provide you with the best service and solution. Let us make a better world for our industry!



Contact us

Tel: +86-755-8981 8866 Fax: +86-755-8427 6832

Email & Skype: info@chipsmall.com Web: www.chipsmall.com

Address: A1208, Overseas Decoration Building, #122 Zhenhua RD., Futian, Shenzhen, China



PQxxxFZ5MZxH Series PQxxxFZ01ZxH Series

Low Voltage Operation
Low Power-Loss Voltage Regulators

■ Features

- 1.Low voltage operation (Minimum operating voltage: 1.7V)
1.8V input → available 1.0 to 1.2V
- 2.Surface mount package(equivalent to EIAJ SC-63)
- 3.RoHS directive compliant

■ Applications

- 1.Peripheral equipment of personal computers
- 2.Power supplies for various electronic equipment such as DVD player or STB

■ Model Line-up

Output current (I _o)	Package type	Output voltage (V _o)	
		1.0V	1.2V
0.5A	Taping	PQ010FZ5MZPH	PQ012FZ5MZPH
	Sleeve	PQ010FZ5MZZH	PQ012FZ5MZZH
1A	Taping	PQ010FZ01ZPH	PQ012FZ01ZPH
	Sleeve	PQ010FZ01ZZH	PQ012FZ01ZZH

■ Absolute Maximum Ratings (Ta=25°C)

Parameter	Symbol	Rating	Unit
Input voltage	V _{IN}	3.7	V
*1 Bias supply voltage	V _B	7	V
Output control voltage	V _C	7	V
Output current	I _o	0.5	A
		1	
*2 Power dissipation	P _D	8	W
*3 Junction temperature	T _j	150	°C
Operating temperature	T _{opr}	-25 to +85	°C
Storage temperature	T _{stg}	-40 to +150	°C
Soldering temperature	T _{sol}	260(10s)	°C

*1 All are open except GND and applicable terminals.
*2 P_D: With infinite heat sink
*3 Overheat protection may operate at T_j:125°C to 150°C

■ Outline Dimensions

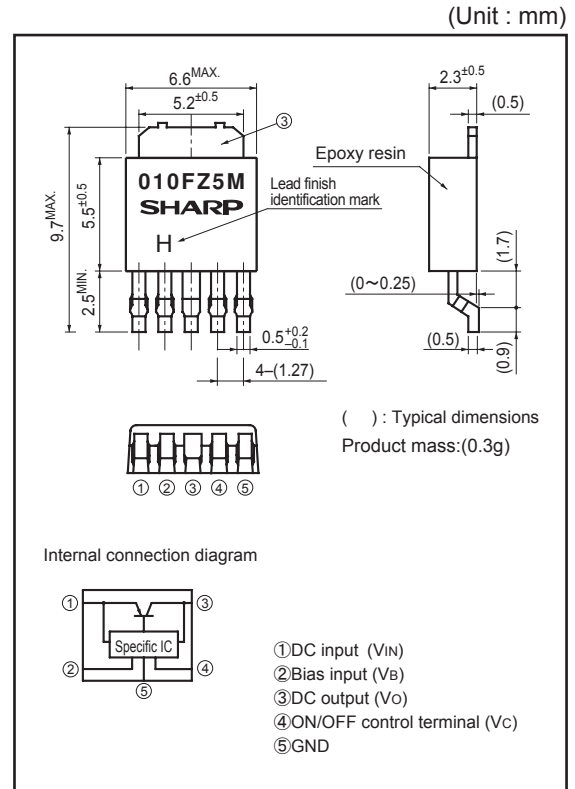

Lead finish:Lead-free solder plating
(Composition: Sn2Cu)

Notice The content of data sheet is subject to change without prior notice.

In the absence of confirmation by device specification sheets, SHARP takes no responsibility for any defects that may occur in equipment using any SHARP devices shown in catalogs, data books, etc. Contact SHARP in order to obtain the latest device specification sheets before using any SHARP device.

Electrical Characteristics

(Unless otherwise specified, condition shall be $V_{IN}=1.8V, V_B=3.3V, I_o=0.3A, V_c=2.7V, T_a=25^\circ C$ (PQxxxFZ5MZxH))
 (Unless otherwise specified, condition shall be $V_{IN}=1.8V, V_B=3.3V, I_o=0.5A, V_c=2.7V, T_a=25^\circ C$ (PQxxxFZ01ZxH))

Parameter	Symbol	Conditions	MIN.	TYP.	MAX.	Unit
Input voltage	V_{IN}	—	1.7	—	3.7	V
Bias supply voltage	V_B	—	2.35	—	7	V
Output voltage	V_o	—	Refer to below table			V
Load regulation	PQxxxFZ5MZxH	RegL $I_o=5mA$ to 0.5A	—	0.2	1	%
	PQxxxFZ01ZxH					
Line regulation	RegI	$V_{IN}=1.7$ to 3.7V, $V_B=2.35$ to 7V, $I_o=5mA$	—	0.2	1	%
Temperature coefficient of output voltage	TcV_o	$T_j=0$ to 125°C, $I_o=5mA$	—	0.5	—	%
Ripple Rejection	PQxxxFZ5MZxH	RR1	—	65	—	dB
	PQxxxFZ01ZxH	RR2	—	60	—	dB
*4 ON-state voltage for control	$V_{C(ON)}$	—	2	—	—	V
ON-state current for control	$I_{C(ON)}$	—	—	—	200	μA
OFF-state voltage for control	$V_{C(OFF)}$	—	—	—	0.8	V
OFF-state current for control	$I_{C(OFF)}$	$V_c=0.4V$	—	—	2	μA
Bias inflow current	I_B	$I_o=0A$	—	1.5	3	mA
Output OFF-state dissipation current	I_{qs}	$I_o=0A, V_c=0.4V$	—	—	10	μA

*4 In case of opening control terminal ④, output voltage turns off.

Output voltage

(Unless otherwise specified, condition shall be $V_{IN}=1.8V, V_B=3.3V, I_o=0.3A, V_c=2.7V, T_a=25^\circ C$ (PQxxxFZ5MZxH))
 (Unless otherwise specified, condition shall be $V_{IN}=1.8V, V_B=3.3V, I_o=0.5A, V_c=2.7V, T_a=25^\circ C$ (PQxxxFZ01ZxH))

Model No.	Symbol	Conditions	MIN.	TYP.	MAX.	Unit
PQ010FZ5MZxH / PQ010FZ01ZxH	V_o	—	0.97	1.0	1.03	V
PQ012FZ5MZxH / PQ012FZ01ZxH	V_o	—	1.17	1.2	1.23	

Fig.1 Test Circuit

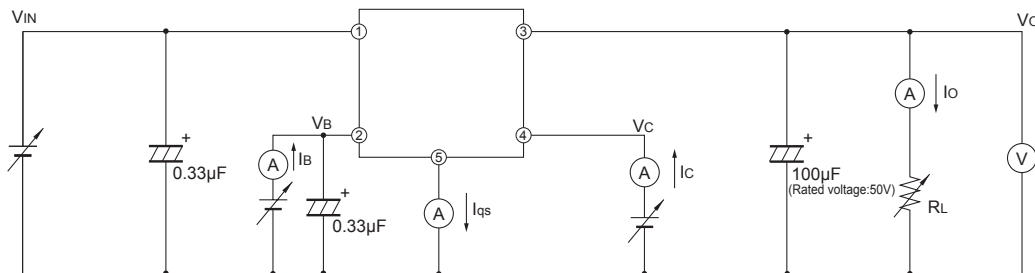

Fig.2 Test Circuit for Ripple Rejection

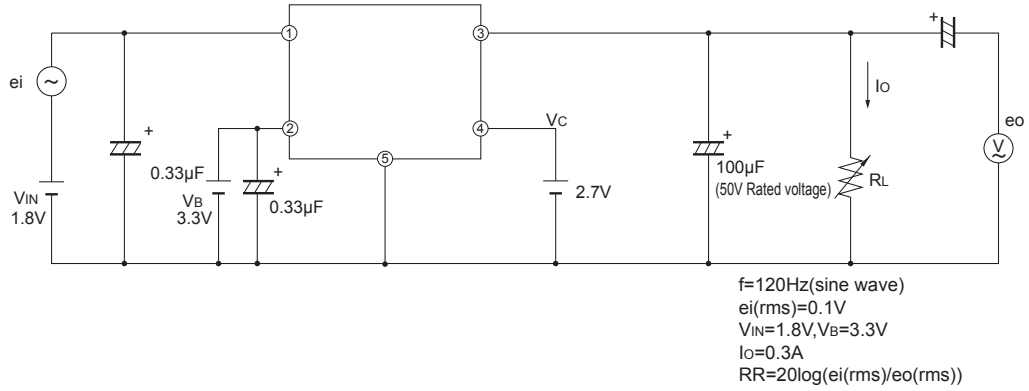

Fig.3 Test Circuit for Ripple Rejection

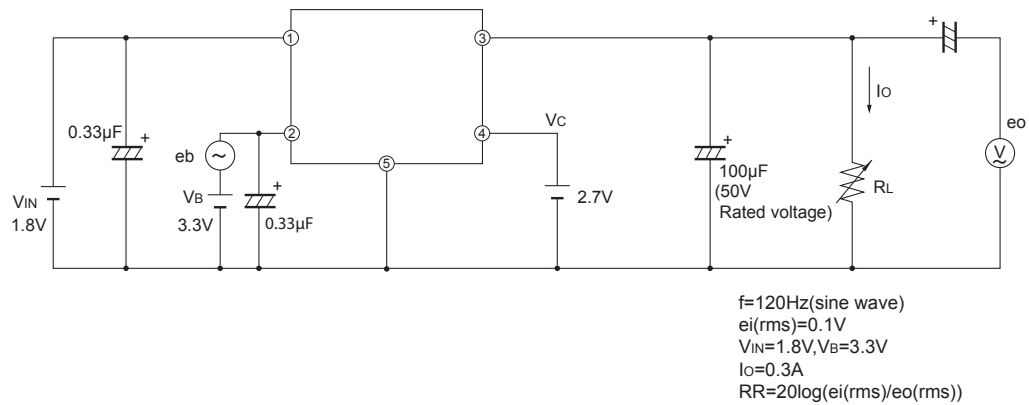
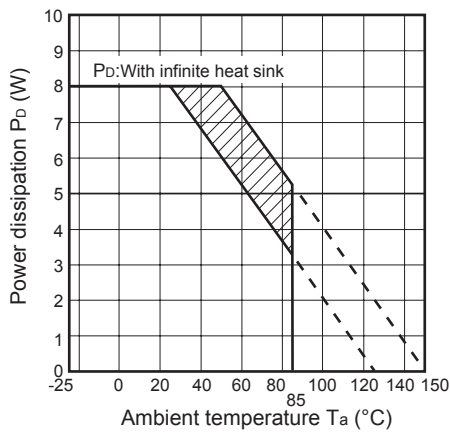

Fig.4 Power Dissipation vs. Ambient Temperature



Note) Oblique line portion: Overheat protection may operate in this area.

Fig.5 Overcurrent Protection Characteristics (PQ010FZ5MZxH)

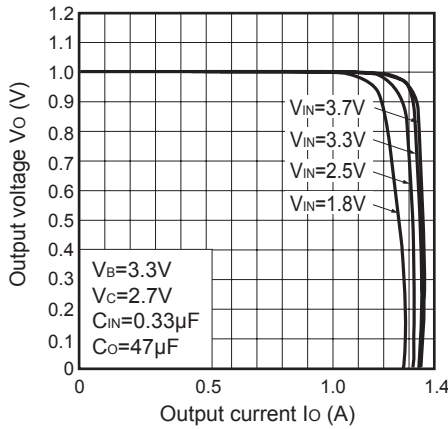

Fig.6 Overcurrent Protection Characteristics (PQ012FZ5MZxH)

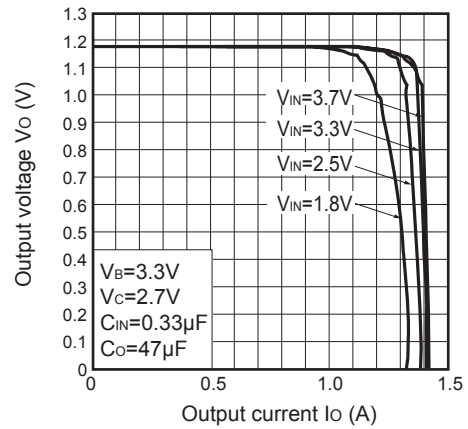

Fig.7 Overcurrent Protection Characteristics (PQ010FZ01ZxH)

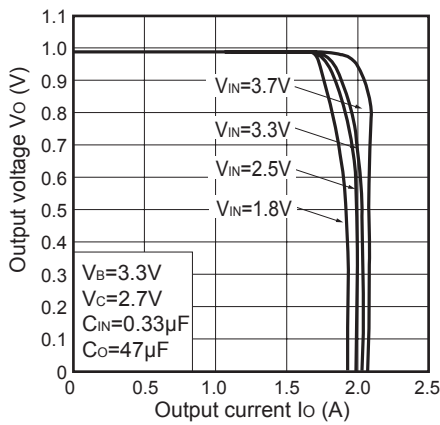

Fig.8 Overcurrent Protection Characteristics (PQ012FZ01ZxH)

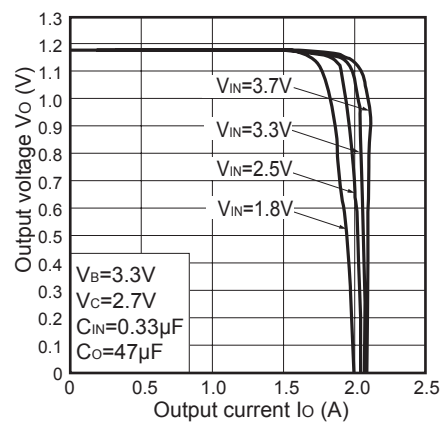

Fig.9 Output Voltage vs. Ambient Temperature (PQ010FZ5MZxH / PQ010FZ01ZxH)

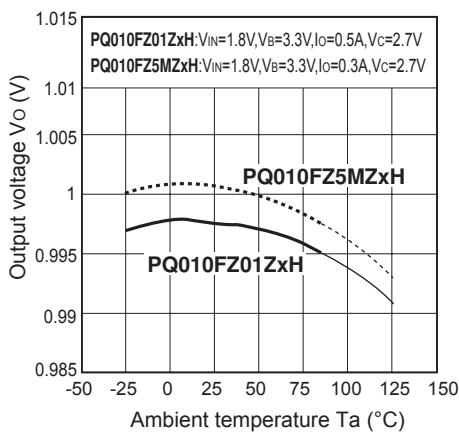

Fig.10 Output Voltage vs. Ambient Temperature (PQ012FZ5MZxH / PQ012FZ01ZxH)

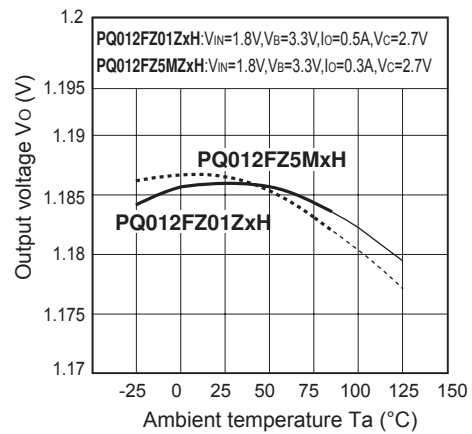

Fig.11 Bias Inflow Current vs. Ambient Temperature

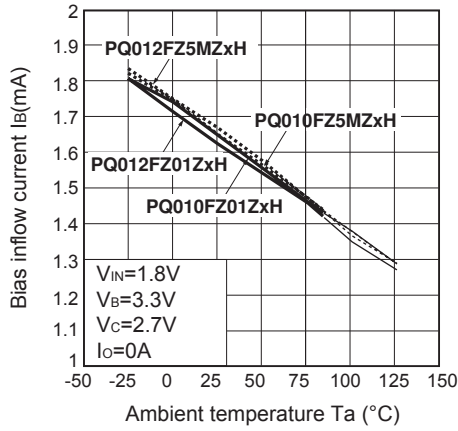

Fig.12 Output Short-circuit Current vs. Ambient Temperature (Reference)

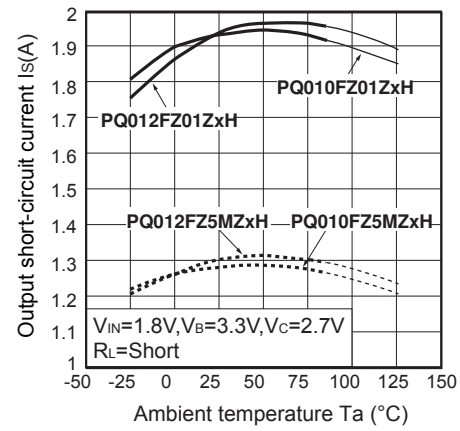

Fig.13 Output Voltage vs. Input Voltage (PQ010FZ5MZxH)

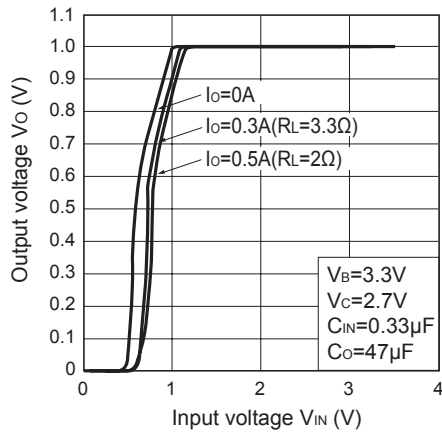

Fig.14 Output Voltage vs. Input Voltage (PQ012FZ5MZxH)

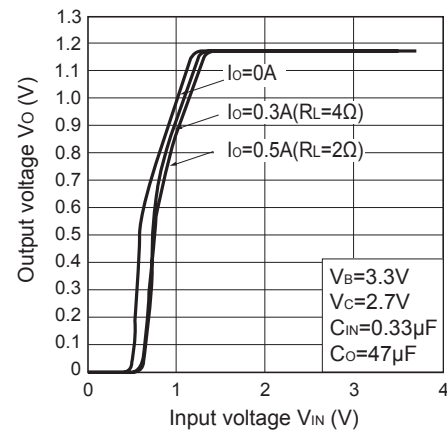

Fig.15 Output Voltage vs. Input Voltage (PQ010FZ01ZxH)

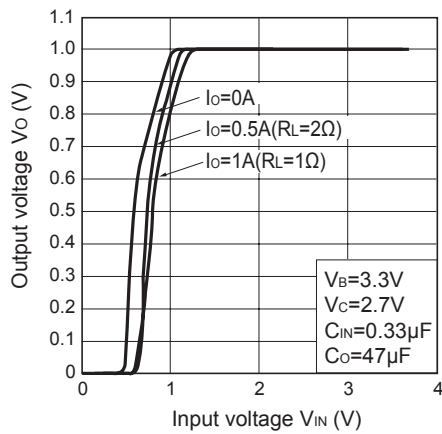

Fig.16 Output Voltage vs. Input Voltage (PQ012FZ01ZxH)

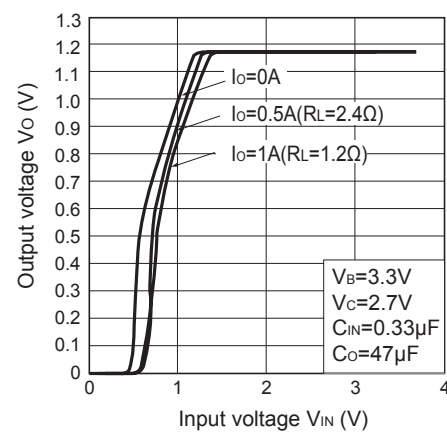

Fig.17 Output Voltage vs. Bias Supply Voltage (PQ010FZ5MZxH)

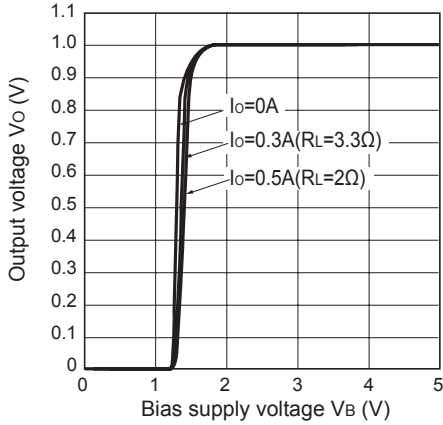

Fig.18 Output Voltage vs. Bias Supply Voltage (PQ012FZ5MZxH)

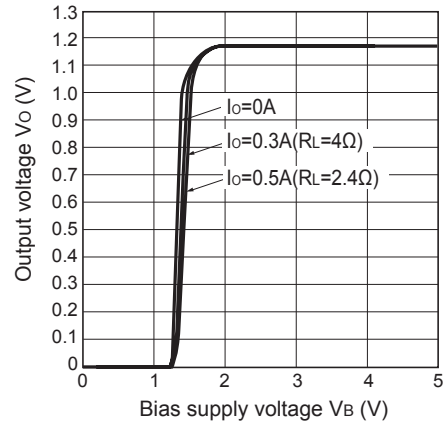

Fig.19 Output Voltage vs. Bias Supply Voltage (PQ010FZ01ZxH)

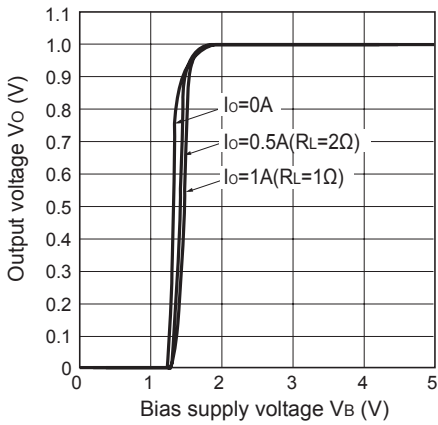

Fig.20 Output Voltage vs. Bias Supply Voltage (PQ012FZ01ZxH)

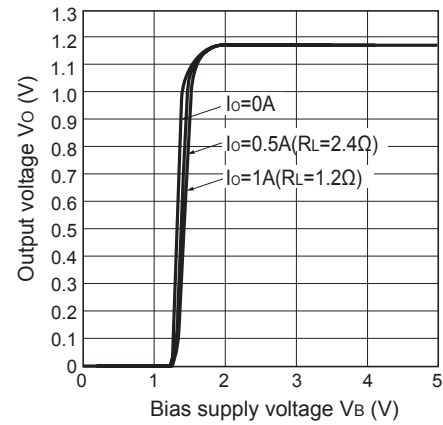

Fig.21 Circuit Operating Current vs. Input Voltage / Bias Supply Voltage (PQ010FZ5MZxH)

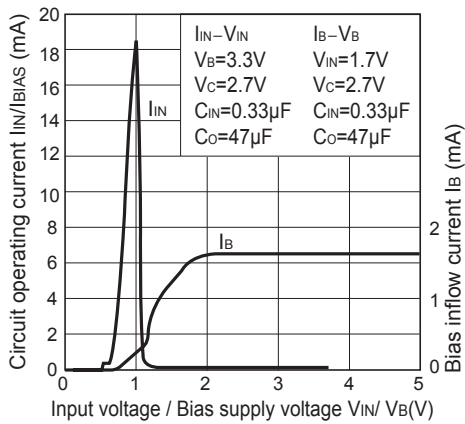

Fig.22 Circuit Operating Current vs. Input Voltage / Bias Supply Voltage (PQ012FZ5MZxH)

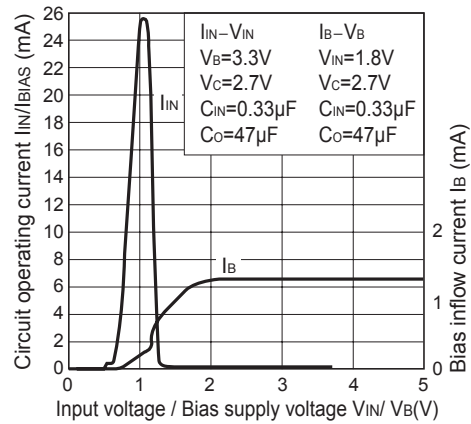

Fig.23 Circuit Operating Current vs. Input Voltage / Bias Supply Voltage (PQ010FZ01ZxH)

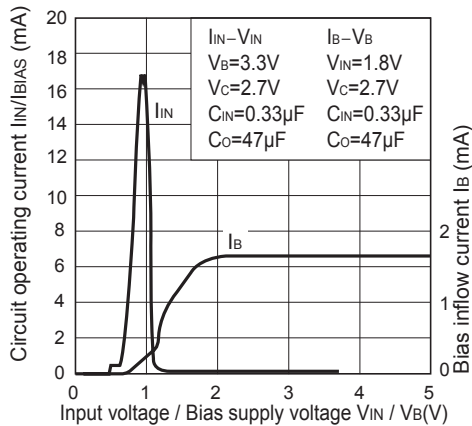

Fig.24 Circuit Operating Current vs. Input Voltage / Bias Supply Voltage (PQ012FZ01ZxH)

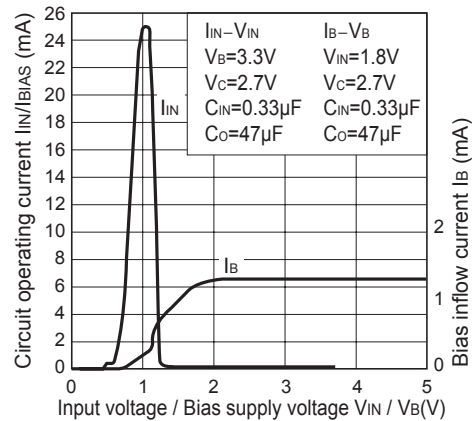

Fig.25 Output Voltage Deviation vs. Input Voltage / Bias Supply Voltage (PQ010FZ5MZxH)

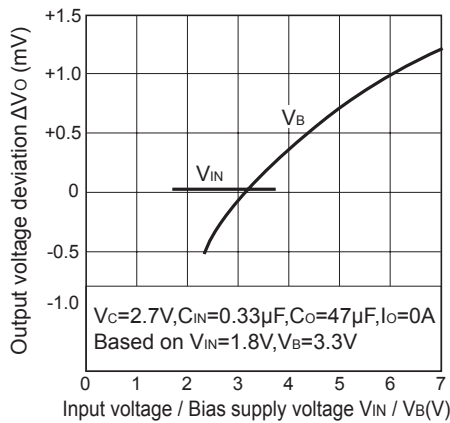

Fig.26 Output Voltage Deviation vs. Input Voltage / Bias Supply Voltage (PQ010FZ01ZxH)

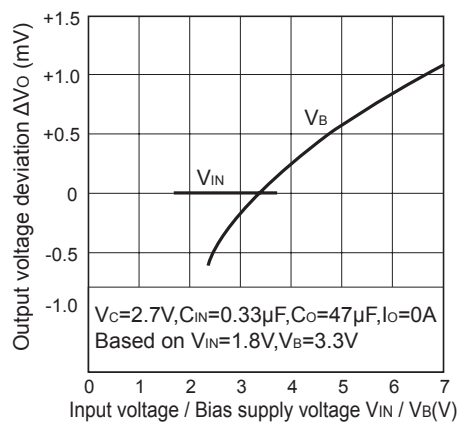

Fig.27 Output Voltage Deviation vs. Input Voltage / Bias Supply Voltage (PQ012FZ5MZxH)

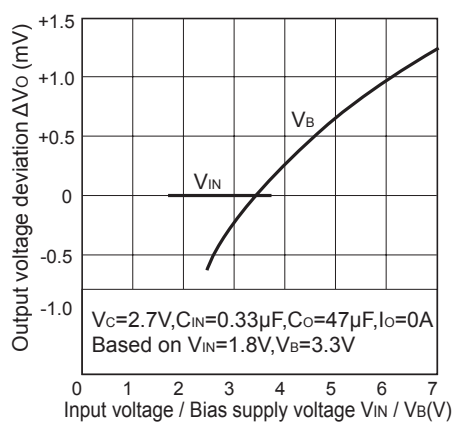

Fig.28 Output Voltage Deviation vs. Input Voltage / Bias Supply Voltage (PQ012FZ01ZxH)

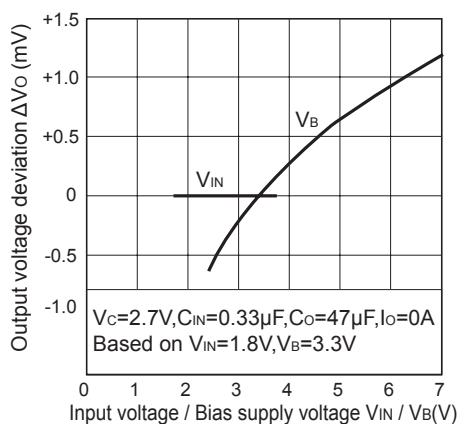

Fig.29 Output Voltage Deviation vs. Output Current

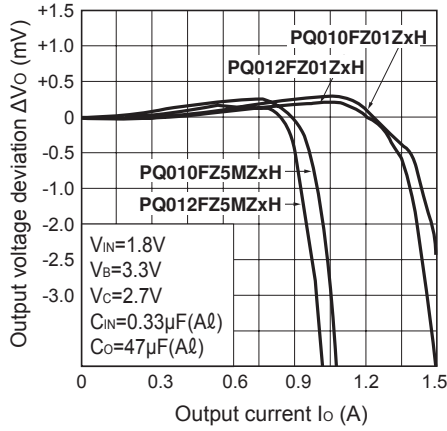

Fig.30 Ripple Rejection vs. Input Ripple Frequency (PQ010FZ5MZxH / PQ010FZ01ZxH)

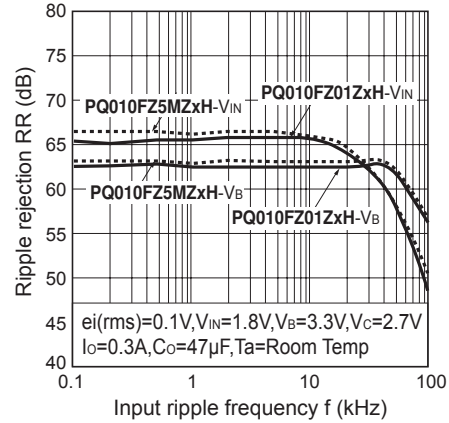

Fig.31 Ripple Rejection vs. Input Ripple Frequency (PQ012FZ5MZxH / PQ012FZ01ZxH)

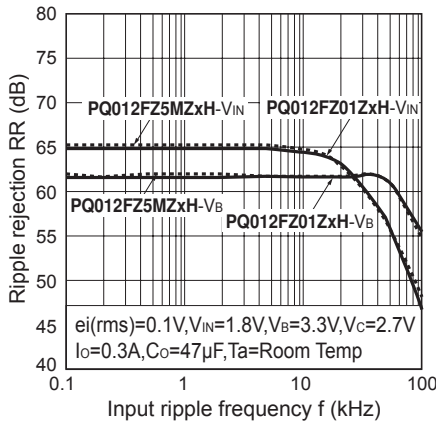

Fig.32 Ripple Rejection vs. Output Current (PQ010FZ5MZxH / PQ010FZ01ZxH)

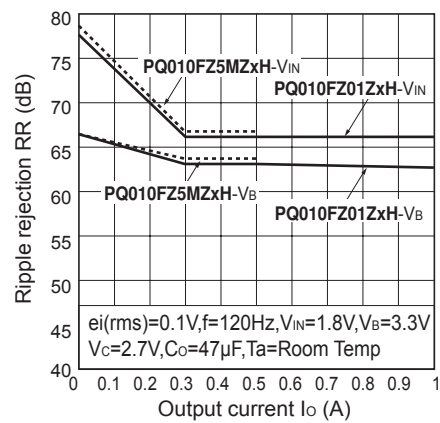

Fig.33 Ripple Rejection vs. Output Current (PQ012FZ5MZxH / PQ012FZ01ZxH)

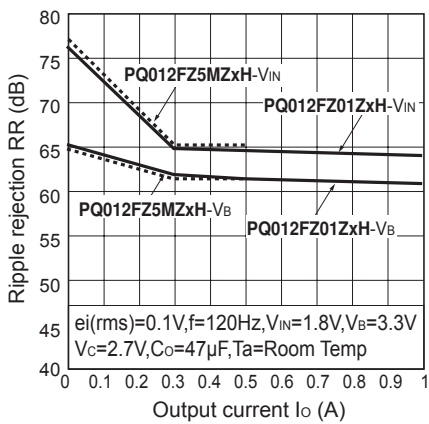

Fig.34 Typical Application

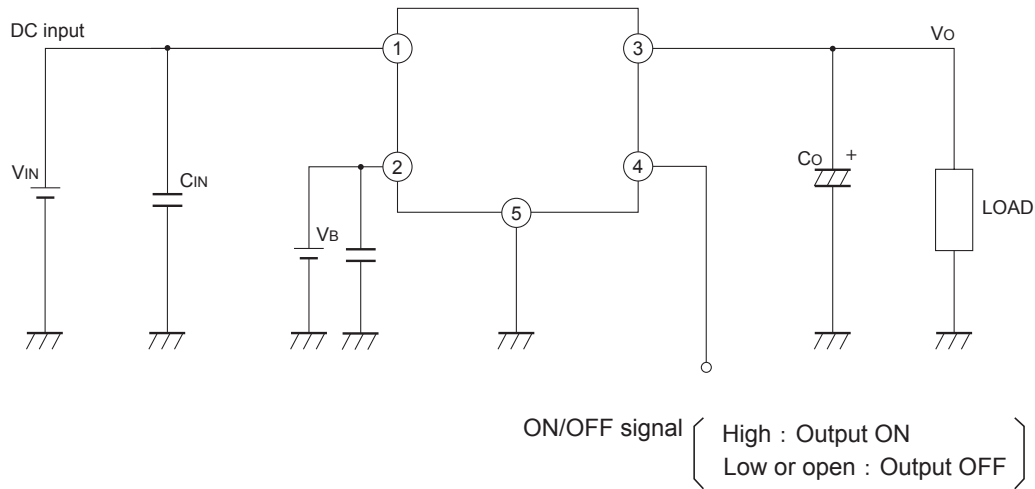

Fig.35 Power Dissipation vs. Ambient Temperature (Typical Value)

