



Chipsmall Limited consists of a professional team with an average of over 10 year of expertise in the distribution of electronic components. Based in Hongkong, we have already established firm and mutual-benefit business relationships with customers from,Europe,America and south Asia,supplying obsolete and hard-to-find components to meet their specific needs.

With the principle of “Quality Parts,Customers Priority,Honest Operation,and Considerate Service”,our business mainly focus on the distribution of electronic components. Line cards we deal with include Microchip,ALPS,ROHM,Xilinx,Pulse,ON,Everlight and Freescale. Main products comprise IC,Modules,Potentiometer,IC Socket,Relay,Connector.Our parts cover such applications as commercial,industrial, and automotives areas.

We are looking forward to setting up business relationship with you and hope to provide you with the best service and solution. Let us make a better world for our industry!



Contact us

Tel: +86-755-8981 8866 Fax: +86-755-8427 6832

Email & Skype: info@chipsmall.com Web: www.chipsmall.com

Address: A1208, Overseas Decoration Building, #122 Zhenhua RD., Futian, Shenzhen, China



SHARP

PQ033ES3MXP

PQ050ES3MXP

Under development

New product

Low Power-Loss Voltage Regulator

Low Output Current, Compact Surface Mount Type Low Power-Loss Voltage Regulators

Features

- (1) Compact package : TO-92 type
(Size(mold part) $5.2 \times 5.5 \times 4.2$ mm)
- (2) Small current output : 300 mA(MAX.)
- (3) Low power-loss :
Dropout voltage : MAX. 0.7 V at $I_o=300$ mA
- (4) Built-in overcurrent, overheat protection functions
- (5) Taped package

Applications

- (1) TV
- (2) VCR
- (3) Air conditioner
- (4) DVD player
- (5) Audio equipment

Outline Dimensions

(Unit: mm)

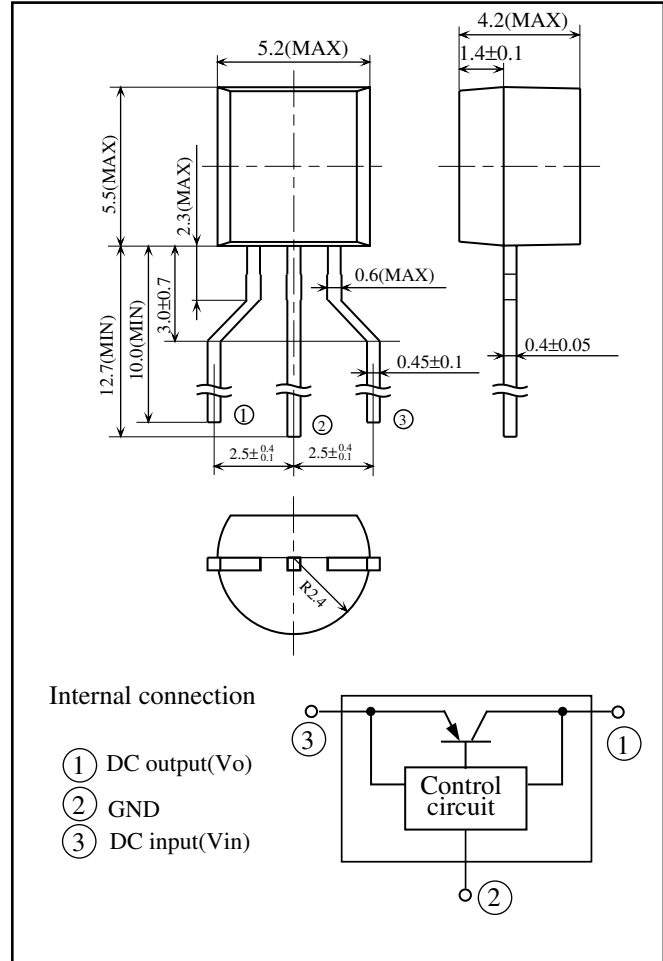

Absolute Maximum Ratings

($T_a=25^\circ\text{C}$)

Parameter	Symbol	Ratings	Unit
*1 Input voltage	V_{in}	9	V
Output current	I_o	300	mA
*2 Power dissipation	P_d	520	mW
*3 Junction temperature	T_j	150	$^\circ\text{C}$
Operating temperature	T_{opr}	-30 to +80	$^\circ\text{C}$
Storage temperature	T_{stg}	-55 to +150	$^\circ\text{C}$
Soldering temperature	T_{sol}	260(For 10s)	$^\circ\text{C}$

*1 All are open except GND and applicable terminals.

*2 At mounted condition

*3 Overheat protection may operate at $125 \leq T_j \leq 150^\circ\text{C}$.

(Notice)

•In the absence of confirmation by device specification sheets, SHARP takes no responsibility for any defects that may occur in equipment using any SHARP devices shown in catalogs, data books, etc. Contact SHARP in order to obtain the latest device specification sheets before using any SHARP device.

•Specifications are subject to change without notice for improvement.

(Internet)

•Data for Sharp's optoelectronic/power devices is provided on internet. (Address <http://sharp-world.com/ecg/>)

SHARP

PQ033ES3MXP

PQ050ES3MXP

Low Power-Loss Voltage Regulator

■ Electrical Characteristics

(Unless otherwise specified, $V_{in}=V_o(\text{TYP.})+1.0\text{V}$, $I_o=30\text{mA}$, $T_a=25^\circ\text{C}$)

Parameter	Symbol	Conditions	MIN.	TYP.	MAX.	Unit
Output voltage	V_o	-	Refer to the table below.			V
Load regulation	RegL	$I_o=5\text{ mA to }300\text{ mA}$	-	35	160	mV
Line regulation	RegI	$V_{in}=V_o(\text{TYP.})+1\text{V to }V_o(\text{TYP.})+6\text{V(MAX. }9\text{V)}$	-	3.0	20	mV
Temperature coefficient of output voltage	T_cV_o	$I_o=10\text{mA}$, $T_j=-25\text{ to }+75^\circ\text{C}$	-	0.05	-	mV/ $^\circ\text{C}$
Ripple rejection	RR	-	-	55	-	dB
Dropout voltage	V_{i-o}	$I_o=300\text{ mA}$, $V_{in}=\ast 4$	-	0.3	0.7	V
Quiescent current	I_q	$I_o=0\text{mA}$	-	190	650	μA

$\ast 4$ Dropout voltage when output voltage lowers 0.1V from the voltage at $V_{in}=V_o+1\text{V}$.

■ Output Voltage Line-up

($V_{in}=V_o(\text{TYP.})+1.0\text{V}$, $I_o=30\text{mA}$, $T_a=25^\circ\text{C}$)

Parameter	Symbol	Conditions	MIN.	TYP.	MAX.	Unit
Output voltage	PQ033ES3MXP	-	3.234	3.3	3.366	V
	PQ050ES3MXP		4.900	5.0	5.100	

NOTICE

- The circuit application examples in this publication are provided to explain representative applications of SHARP devices and are not intended to guarantee any circuit design or license any intellectual property rights. SHARP takes no responsibility for any problems related to any intellectual property right of a third party resulting from the use of SHARP's devices.
- Contact SHARP in order to obtain the latest device specification sheets before using any SHARP device. SHARP reserves the right to make changes in the specifications, characteristics, data, materials, structure, and other contents described herein at any time without notice in order to improve design or reliability. Manufacturing locations are also subject to change without notice.
- Observe the following points when using any devices in this publication. SHARP takes no responsibility for damage caused by improper use of the devices which does not meet the conditions and absolute maximum ratings to be used specified in the relevant specification sheet nor meet the following conditions:
 - (i) The devices in this publication are designed for use in general electronic equipment designs such as:
 - Personal computers
 - Office automation equipment
 - Telecommunication equipment [terminal]
 - Test and measurement equipment
 - Industrial control
 - Audio visual equipment
 - Consumer electronics
 - (ii) Measures such as fail-safe function and redundant design should be taken to ensure reliability and safety when SHARP devices are used for or in connection with equipment that requires higher reliability such as:
 - Transportation control and safety equipment (i.e., aircraft, trains, automobiles, etc.)
 - Traffic signals
 - Gas leakage sensor breakers
 - Alarm equipment
 - Various safety devices, etc.
 - (iii) SHARP devices shall not be used for or in connection with equipment that requires an extremely high level of reliability and safety such as:
 - Space applications
 - Telecommunication equipment [trunk lines]
 - Nuclear power control equipment
 - Medical and other life support equipment (e.g., scuba).
- If the SHARP devices listed in this publication fall within the scope of strategic products described in the Foreign Exchange and Foreign Trade Law of Japan, it is necessary to obtain approval to export such SHARP devices.
- This publication is the proprietary product of SHARP and is copyrighted, with all rights reserved. Under the copyright laws, no part of this publication may be reproduced or transmitted in any form or by any means, electronic or mechanical, for any purpose, in whole or in part, without the express written permission of SHARP. Express written permission is also required before any use of this publication may be made by a third party.
- Contact and consult with a SHARP representative if there are any questions about the contents of this publication.