



Chipsmall Limited consists of a professional team with an average of over 10 year of expertise in the distribution of electronic components. Based in Hongkong, we have already established firm and mutual-benefit business relationships with customers from,Europe,America and south Asia,supplying obsolete and hard-to-find components to meet their specific needs.

With the principle of “Quality Parts,Customers Priority,Honest Operation,and Considerate Service”,our business mainly focus on the distribution of electronic components. Line cards we deal with include Microchip,ALPS,ROHM,Xilinx,Pulse,ON,Everlight and Freescale. Main products comprise IC,Modules,Potentiometer,IC Socket,Relay,Connector.Our parts cover such applications as commercial,industrial, and automotives areas.

We are looking forward to setting up business relationship with you and hope to provide you with the best service and solution. Let us make a better world for our industry!



## Contact us

Tel: +86-755-8981 8866 Fax: +86-755-8427 6832

Email & Skype: info@chipsmall.com Web: www.chipsmall.com

Address: A1208, Overseas Decoration Building, #122 Zhenhua RD., Futian, Shenzhen, China



# PQ05RR1/11/1B

1A Output, Low Power-Loss Voltage Regulators(Built-in Reset Signal Generating Function)

## ■ Features

- Low power-loss (Dropout voltage : MAX. 0.5V)
- Compact resin full-mold package
- Built-in reset signal generating function to prevent errors of microcomputer when the output voltage drops.
- Lead forming type (PQ05RR1B) is also available.

## ■ Applications

- Series power supply for equipment provided with microcomputer such as electronic musical instruments and VCRs

## ■ Model Line-ups

Output voltage	5V output
Output voltage precision:±5%	PQ05RR1
Output voltage precision:±2.5%	PQ05RR11

## ■ Outline Dimensions

(Unit : mm)

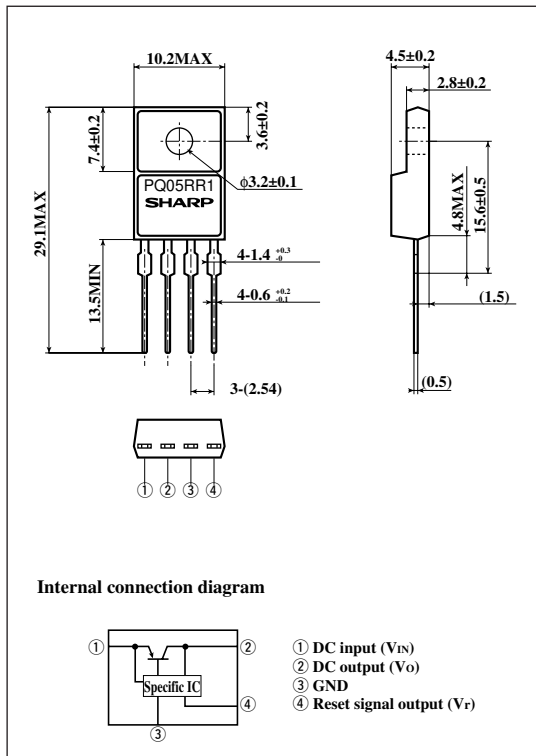

## ■ Absolute Maximum Ratings

(T<sub>a</sub>=25°C)

Parameter	Symbol	Rating	Unit
*1 Input voltage	V <sub>IN</sub>	35	V
*1 Reset output voltage	V <sub>r</sub>	35	V
Output current	I <sub>o</sub>	1	A
Reset output current	I <sub>r</sub>	10	mA
Power dissipation(No heat sink)	P <sub>D1</sub>	1.5	W
*2 Power dissipation(With infinite heat sink)	P <sub>D2</sub>	15	W
Junction temperature	T <sub>j</sub>	150	°C
Operating temperature	T <sub>opr</sub>	-20 to +80	°C
Storage temperature	T <sub>stg</sub>	-40 to +150	°C
Soldering temperature	T <sub>sol</sub>	260 (For 10s)	°C

\*1 All are open except GND and applicable terminals.

\*2 Overheat protection may operate at 125<=T<sub>j</sub><=150°C

■ Electrical Characteristics

(Unless otherwise specified, condition shall be  $V_{IN}=7V$ ,  $I_o=0.5A$ ,  $T_a=25^{\circ}C$ )

Parameter	Symbol	Conditions	MIN.	TYP.	MAX.	Unit
Output voltage	PQ05RR1	-	4.75	5.0	5.25	V
	PQ05RR11		4.88	5.0	5.12	
Load regulation	$R_{egL}$	$I_o=5mA$ to 1.0A	-	0.1	2.0	%
Line regulation	$R_{egI}$	$V_{IN}=6$ to 12V	-	0.5	2.5	%
Temperature coefficient of output voltage	$T_{cV_o}$	$T_j=0$ to $125^{\circ}C$	-	$\pm 0.02$	-	%/°C
Ripple rejection	RR	Refer to Fig. 2	45	55	-	dB
Dropout voltage	$V_{i-o}$	<sup>*3</sup>	-	-	0.5	V
Low reset output voltage	$V_{rl}$	$I_o=5mA$ , $I_r=5mA$	-	-	0.8	V
Reset threshold voltage	$V_{rt}$	$I_o=5mA$	$V_o-0.25$	-	$V_o-0.1$	V
Reset output leak current	$I_{rlk}$	$I_o=5mA$ , $V_r=35V$	-	-	30	$\mu A$
Quiescent current	$I_q$	$I_o=0$	-	-	10	mA

\*3 Input voltage shall be the value when output voltage is 95% in comparison with the initial value.

Fig.1 Test Circuit

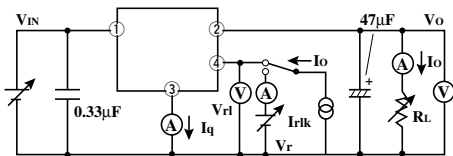
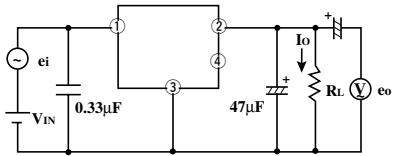
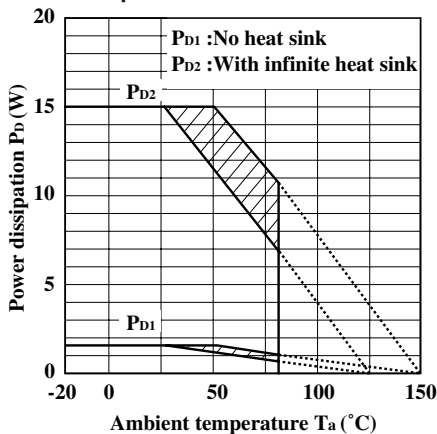

Fig.2 Test Circuit of Ripple Rejection



$f=120Hz$  (sine wave)  
 $e_i=0.5V_{rms}$   
 $RR=20 \log (e_i/e_o)$

Fig.3 Power Dissipation vs. Ambient Temperature



Note) Oblique line portion: Overheat protection may operate in this area.

Fig.4 Overcurrent Protection Characteristics (Typical Value)

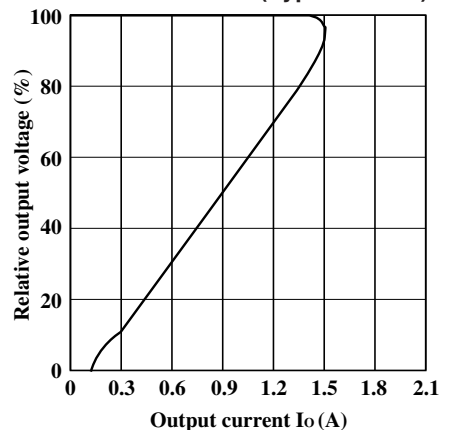

Fig.5 Output Voltage Deviation vs. Junction Temperature

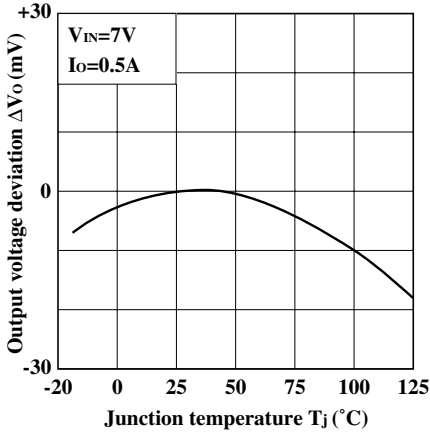

Fig.6 Output Voltage vs. Input Voltage (Typical Value)

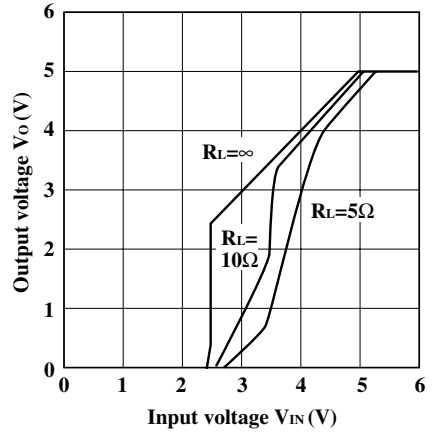

Fig.7 Circuit Operating Current vs. Input Voltage (Typical Value)

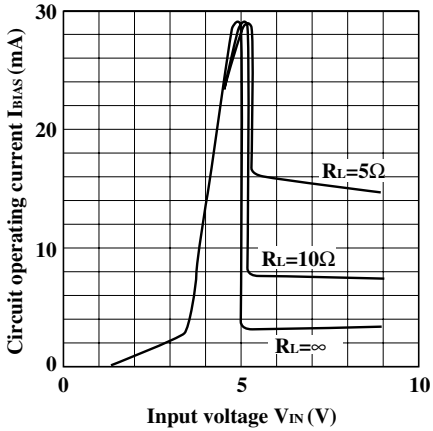

Fig.8 Quiescent Current vs. Junction Temperature

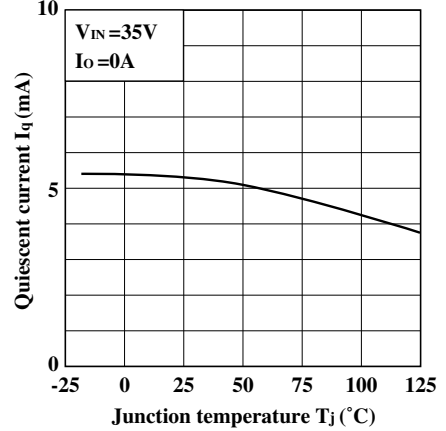

Fig.9 Ripple Rejection vs. Input Ripple Frequency

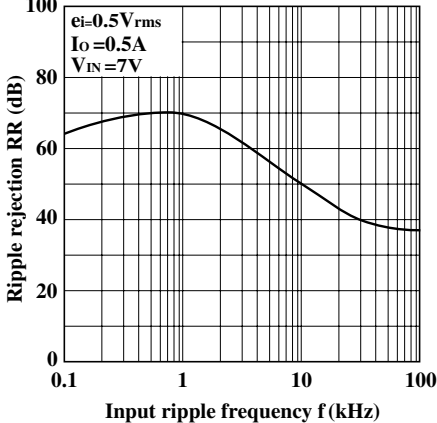

Fig.10 Ripple Rejection vs. Output Current

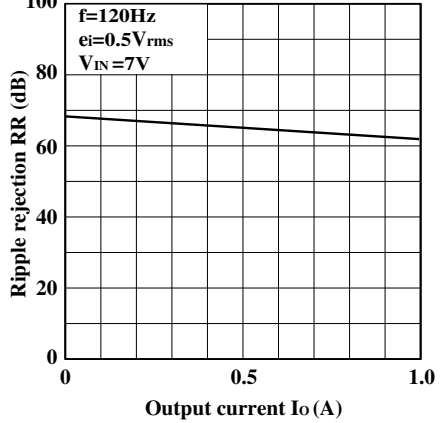

Fig.11 Output Peak Current vs. Junction Temperature

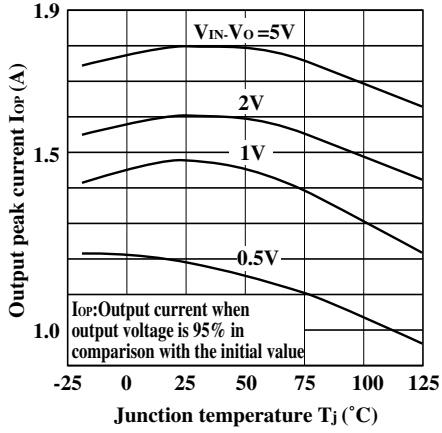
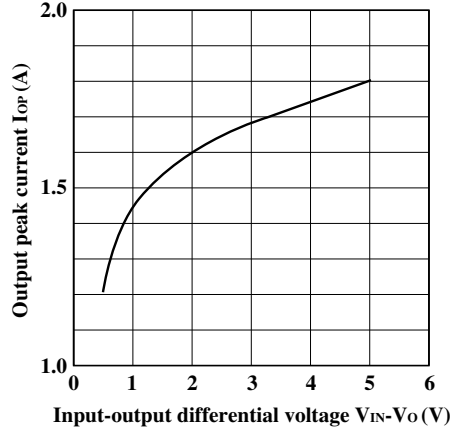
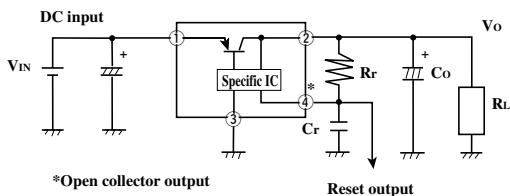

Fig.12 Output Peak Current vs. Input-output differential voltage



■ Typical Application



■ Reset Output Response Characteristics

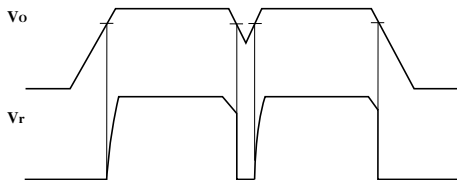

■ Model Line-up for Lead Forming Type

Output voltage	5Voutput
Output voltage precision:±2.5%	PQ05RR1B

■ Outline Dimensions

(Unit : mm)

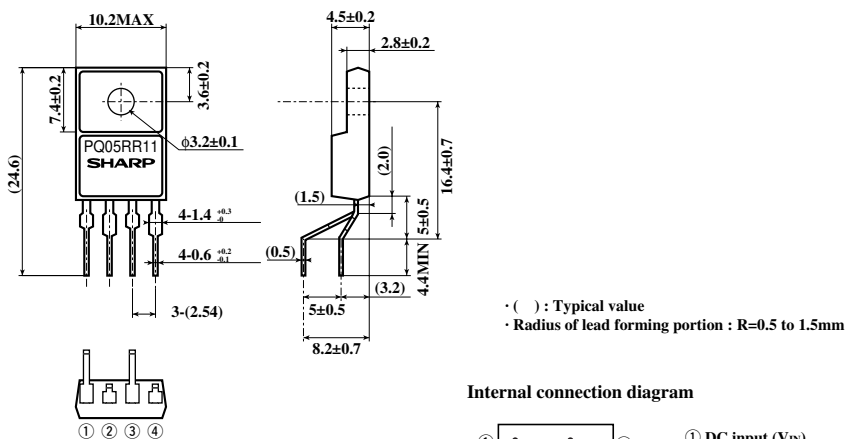

Internal connection diagram

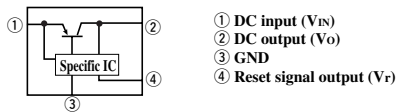

Note) The value of absolute maximum ratings and electrical characteristics is same as ones of PQ05RR11.

### NOTICE

- The circuit application examples in this publication are provided to explain representative applications of SHARP devices and are not intended to guarantee any circuit design or license any intellectual property rights. SHARP takes no responsibility for any problems related to any intellectual property right of a third party resulting from the use of SHARP's devices.
- Contact SHARP in order to obtain the latest device specification sheets before using any SHARP device. SHARP reserves the right to make changes in the specifications, characteristics, data, materials, structure, and other contents described herein at any time without notice in order to improve design or reliability. Manufacturing locations are also subject to change without notice.
- Observe the following points when using any devices in this publication. SHARP takes no responsibility for damage caused by improper use of the devices which does not meet the conditions and absolute maximum ratings to be used specified in the relevant specification sheet nor meet the following conditions:
  - (i) The devices in this publication are designed for use in general electronic equipment designs such as:
    - Personal computers
    - Office automation equipment
    - Telecommunication equipment [terminal]
    - Test and measurement equipment
    - Industrial control
    - Audio visual equipment
    - Consumer electronics
  - (ii) Measures such as fail-safe function and redundant design should be taken to ensure reliability and safety when SHARP devices are used for or in connection with equipment that requires higher reliability such as:
    - Transportation control and safety equipment (i.e., aircraft, trains, automobiles, etc.)
    - Traffic signals
    - Gas leakage sensor breakers
    - Alarm equipment
    - Various safety devices, etc.
  - (iii) SHARP devices shall not be used for or in connection with equipment that requires an extremely high level of reliability and safety such as:
    - Space applications
    - Telecommunication equipment [trunk lines]
    - Nuclear power control equipment
    - Medical and other life support equipment (e.g., scuba).
- Contact a SHARP representative in advance when intending to use SHARP devices for any "specific" applications other than those recommended by SHARP or when it is unclear which category mentioned above controls the intended use.
- If the SHARP devices listed in this publication fall within the scope of strategic products described in the Foreign Exchange and Foreign Trade Control Law of Japan, it is necessary to obtain approval to export such SHARP devices.
- This publication is the proprietary product of SHARP and is copyrighted, with all rights reserved. Under the copyright laws, no part of this publication may be reproduced or transmitted in any form or by any means, electronic or mechanical, for any purpose, in whole or in part, without the express written permission of SHARP. Express written permission is also required before any use of this publication may be made by a third party.
- Contact and consult with a SHARP representative if there are any questions about the contents of this publication.