



Chipsmall Limited consists of a professional team with an average of over 10 year of expertise in the distribution of electronic components. Based in Hongkong, we have already established firm and mutual-benefit business relationships with customers from,Europe,America and south Asia,supplying obsolete and hard-to-find components to meet their specific needs.

With the principle of “Quality Parts,Customers Priority,Honest Operation,and Considerate Service”,our business mainly focus on the distribution of electronic components. Line cards we deal with include Microchip,ALPS,ROHM,Xilinx,Pulse,ON,Everlight and Freescale. Main products comprise IC,Modules,Potentiometer,IC Socket,Relay,Connector.Our parts cover such applications as commercial,industrial, and automotives areas.

We are looking forward to setting up business relationship with you and hope to provide you with the best service and solution. Let us make a better world for our industry!



Contact us

Tel: +86-755-8981 8866 Fax: +86-755-8427 6832

Email & Skype: info@chipsmall.com Web: www.chipsmall.com

Address: A1208, Overseas Decoration Building, #122 Zhenhua RD., Futian, Shenzhen, China



PQ070XH01ZxH

Low Voltage Operation
Low Power-Loss Voltage Regulator

■ Features

1. Low voltage operation
(Minimum operating voltage: 2.35V)
2. Output current : 1A
3. Low dissipation current
(Dissipation current at no load: MAX. 2mA
Output OFF-state dissipation current: MAX.5μA)
4. Low power-loss (V_{i-o} 0.5V MAX at $I_o=0.5A$)
5. Built-in overcurrent and overheat protection functions
6. TO-263 package
7. RoHS directive compliant

■ Applications

1. Peripheral equipment of personal computers
2. Power supplies for various electronic equipment such as DVD player or STB

■ Model Line-up

Output current (I_o)	Package type	Variable output
1A	Taping	PQ070XH01ZPH
	Sleeve	PQ070XH01ZZH

■ Absolute Maximum Ratings

($T_a=25^{\circ}C$)

Parameter	Symbol	Rating	Unit
*1 Input voltage	V_{IN}	10	V
*1 ON/OFF control terminal voltage	V_C	10	V
*1 Output adjustment terminal voltage	V_{ADJ}	5	V
Output current	I_o	1	A
*2 Power dissipation	P_D	35	W
*3 Junction temperature	T_j	150	$^{\circ}C$
Operating temperature	T_{opr}	-40 to +85	$^{\circ}C$
Storage temperature	T_{stg}	-40 to +150	$^{\circ}C$
Soldering temperature	T_{sol}	260(10s)	$^{\circ}C$

*1 All are open except GND and applicable terminals.
*2 P_D : With infinite heat sink
*3 Overheat protection may operate at T_j : 125 $^{\circ}C$ to 150 $^{\circ}C$

■ Outline Dimensions

(Unit : mm)

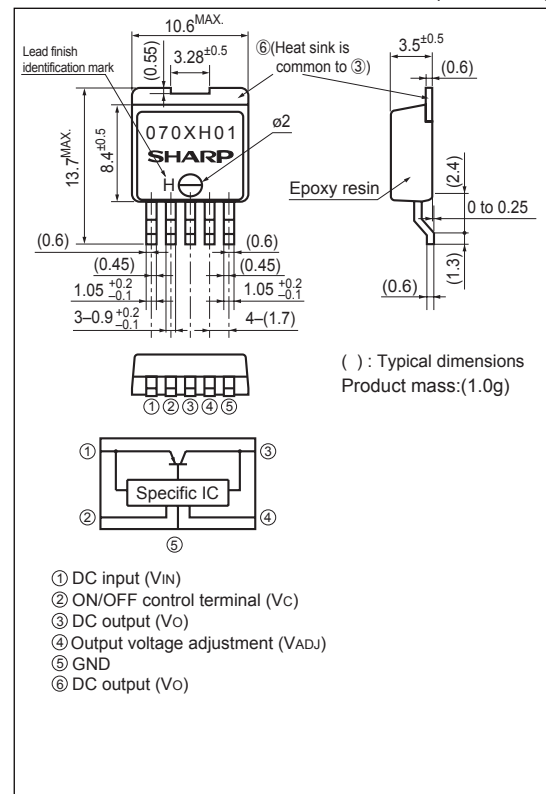

Lead finish: Lead-free solder plating
(Composition: Sn2Cu)

Notice The content of data sheet is subject to change without prior notice.

In the absence of confirmation by device specification sheets, SHARP takes no responsibility for any defects that may occur in equipment using any SHARP devices shown in catalogs, data books, etc. Contact SHARP in order to obtain the latest device specification sheets before using any SHARP device.

Electrical Characteristics

(Unless otherwise specified, condition shall be $V_{IN}=5V, V_O=3V (R_1=1k\Omega), I_O=0.5A, T_a=25^\circ C$)

Parameter	Symbol	Conditions	MIN.	TYP.	MAX.	Unit
Input voltage	V_{IN}	-	2.35	-	10	V
Output voltage	V_O	-	1.5	-	7	V
Reference voltage	V_{ref}	-	1.225	1.25	1.275	V
Load regulation	Reg_L	$I_O=5mA$ to 1A	-	0.2	2.0	%
Line regulation	Reg_L	$V_{IN}=4$ to 8V, $I_O=5mA$	-	0.2	1.0	%
Temperature coefficient of reference voltage	$T_C V_{ref}$	$T_j=0$ to $+125^\circ C$, $I_O=5mA$	-	± 1.0	-	%
Ripple rejection	RR	Refer to Fig.2	45	60	-	dB
Dropout voltage	V_{I-O}	$V_{IN}=2.85V$, $I_O=0.5A$	-	-	0.5	V
ON-state voltage for control	$V_{C(ON)}$	-	2.0	-	-	V
ON-state current for control	$I_{C(ON)}$	-	-	-	200	μA
OFF-state voltage for control	$V_{C(OFF)}$	$I_O=0A$	-	-	0.8	V
OFF-state current for control	$I_{C(OFF)}$	$I_O=0A, V_C=0.4V$	-	-	2	μA
Quiescent current	I_q	$I_O=0A$	-	1	2	mA
Output OFF-state consumption current	I_{qs}	$I_O=0A, V_C=0.4V$	-	-	5	μA

*4 In case of opening control terminal ②, output voltage turns off

Fig.1 Test Circuit

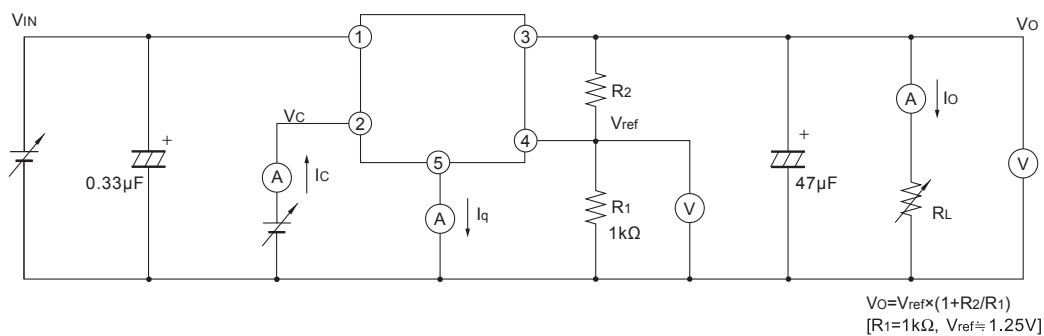

Fig.2 Test Circuit for Ripple Rejection

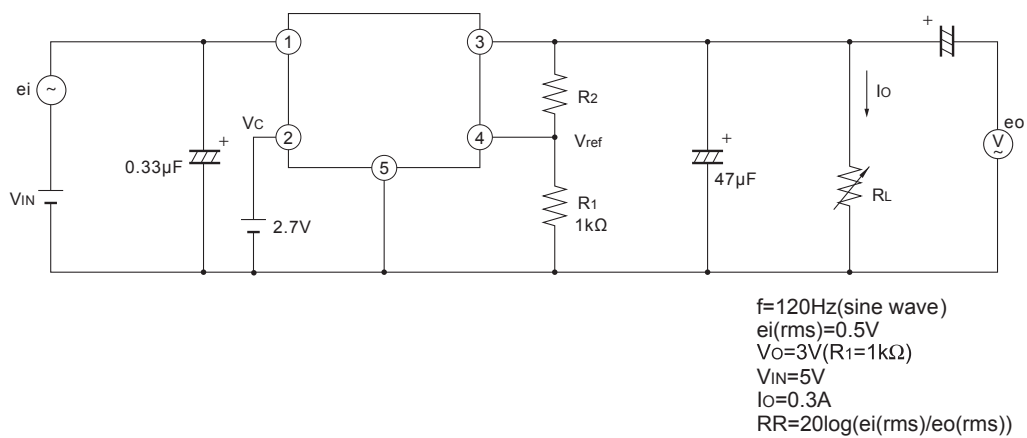
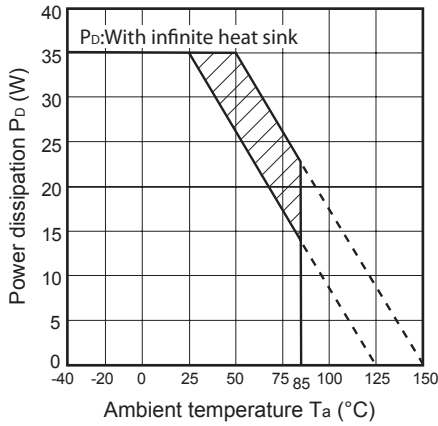

Fig.3 Power Dissipation vs. Ambient Temperature



Note) Oblique line portion: Overheat protection may operate in this area.

Fig.4 Overcurrent Protection Characteristics

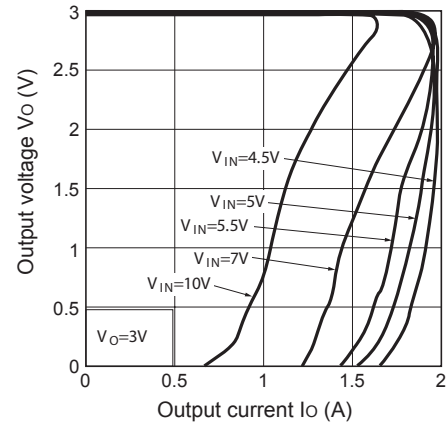

Fig.5 Reference Voltage vs. Junction Temperature

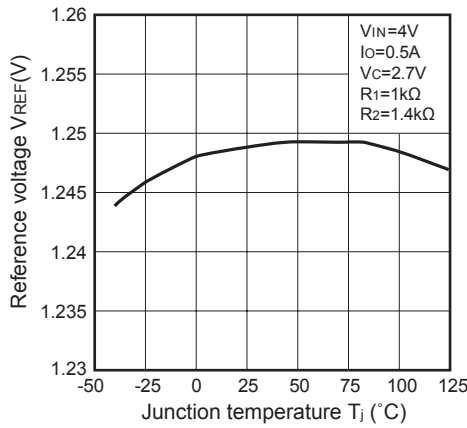

Fig.6 Output Voltage vs. Input Voltage

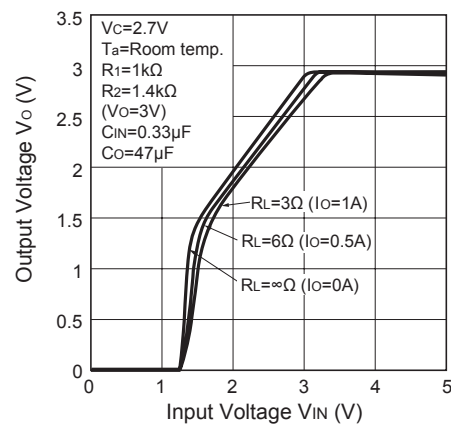

Fig.7 Circuit Operating Current vs. Input Voltage

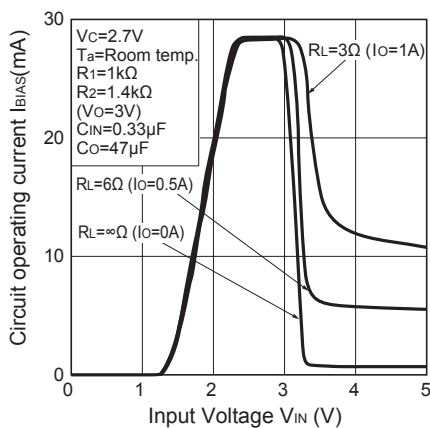

Fig.8 Dropout Voltage vs. Junction Temperature

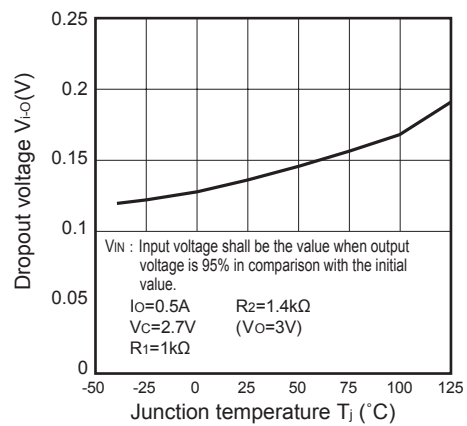

Fig.9 ON-OFF Threshold Voltage vs. Junction Temperature

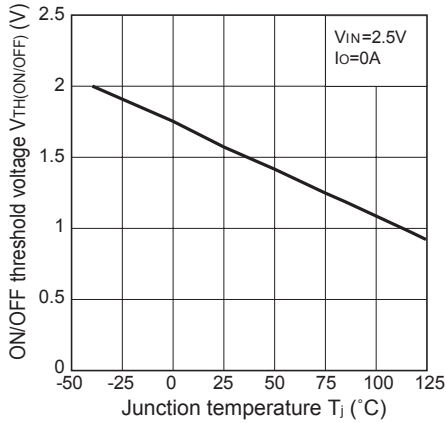

Fig.10 Quiescent Current vs. Junction Temperature

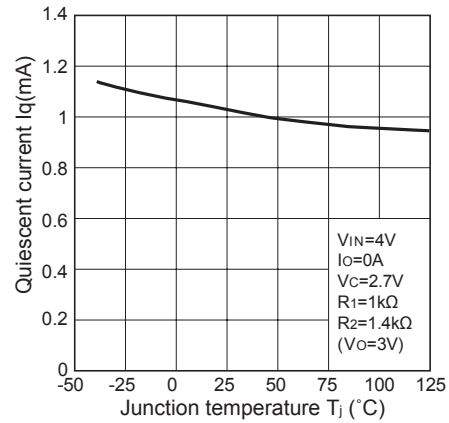

Fig.11 Ripple Rejection vs. Input Ripple Frequency

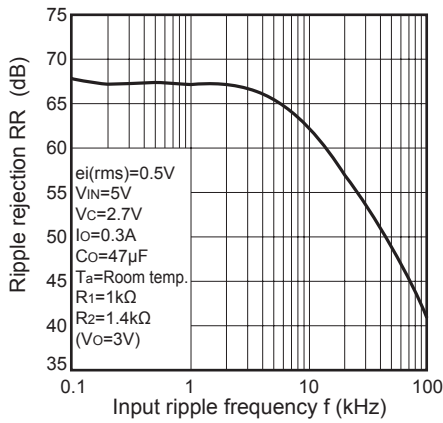

Fig.12 Ripple Rejection vs. Output Current

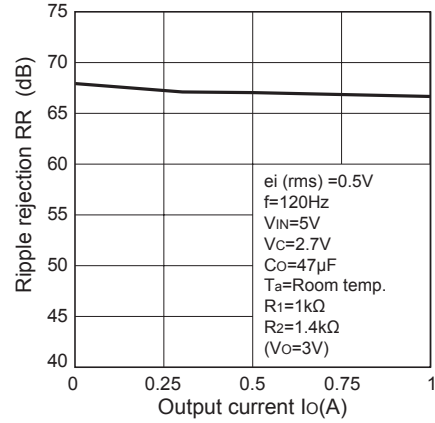
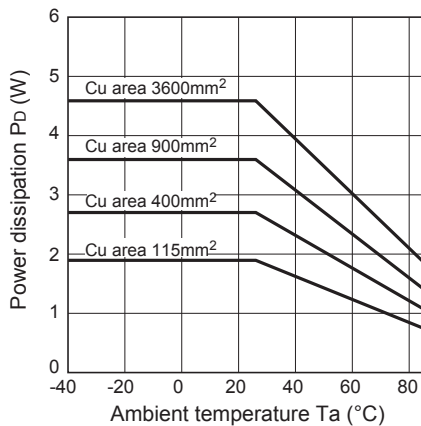
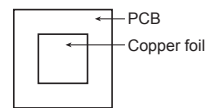

Fig.13 Power Dissipation vs. Ambient Temperature



Mounting PCB



Material : Glass-cloth epoxy resin
 Size : 60×60×1.6mm
 Thickness of copper : 65μm

Fig.14 Output Voltage Adjustment Characteristics (Typical value)

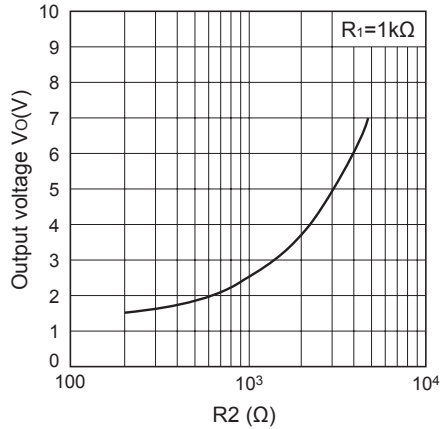

■ Typical Application

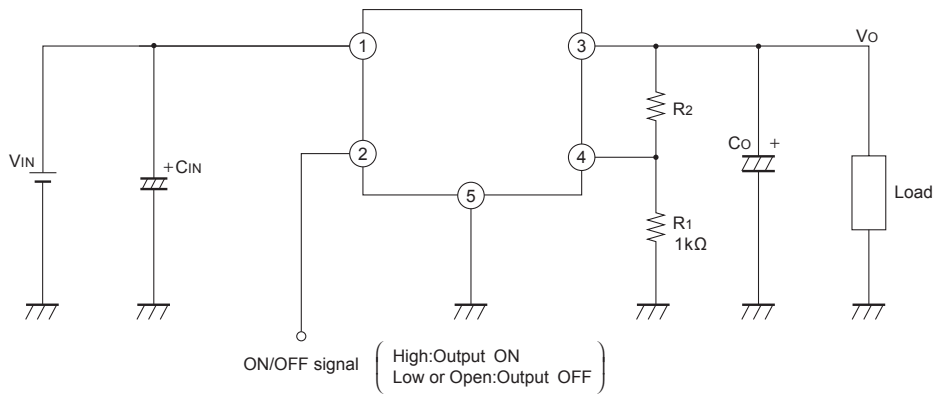

■ Setting of Output Voltage

Output voltage is able to set from 1.5V to 7V when resistors R₁ and R₂ are attached to ,③、④、⑤ terminals. As for the external resistors to set output voltage, refer to the figure below and Fig.14.

