



Chipsmall Limited consists of a professional team with an average of over 10 year of expertise in the distribution of electronic components. Based in Hongkong, we have already established firm and mutual-benefit business relationships with customers from,Europe,America and south Asia,supplying obsolete and hard-to-find components to meet their specific needs.

With the principle of “Quality Parts,Customers Priority,Honest Operation,and Considerate Service”,our business mainly focus on the distribution of electronic components. Line cards we deal with include Microchip,ALPS,ROHM,Xilinx,Pulse,ON,Everlight and Freescale. Main products comprise IC,Modules,Potentiometer,IC Socket,Relay,Connector.Our parts cover such applications as commercial,industrial, and automotives areas.

We are looking forward to setting up business relationship with you and hope to provide you with the best service and solution. Let us make a better world for our industry!



Contact us

Tel: +86-755-8981 8866 Fax: +86-755-8427 6832

Email & Skype: info@chipsmall.com Web: www.chipsmall.com

Address: A1208, Overseas Decoration Building, #122 Zhenhua RD., Futian, Shenzhen, China



Important notice

Dear Customer,

On 7 February 2017 the former NXP Standard Product business became a new company with the tradename **Nexperia**. Nexperia is an industry leading supplier of Discrete, Logic and PowerMOS semiconductors with its focus on the automotive, industrial, computing, consumer and wearable application markets

In data sheets and application notes which still contain NXP or Philips Semiconductors references, use the references to Nexperia, as shown below.

Instead of <http://www.nxp.com>, <http://www.philips.com/> or <http://www.semiconductors.philips.com/>, use <http://www.nexperia.com>

Instead of sales.addresses@www.nxp.com or sales.addresses@www.semiconductors.philips.com, use salesaddresses@nexperia.com (email)

Replace the copyright notice at the bottom of each page or elsewhere in the document, depending on the version, as shown below:

- © NXP N.V. (year). All rights reserved or © Koninklijke Philips Electronics N.V. (year). All rights reserved

Should be replaced with:

- © **Nexperia B.V. (year). All rights reserved.**

If you have any questions related to the data sheet, please contact our nearest sales office via e-mail or telephone (details via salesaddresses@nexperia.com). Thank you for your cooperation and understanding,

Kind regards,

Team Nexperia

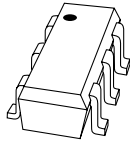

PRTR5V0U4Y

Integrated quad ultra-low capacitance ESD protection

Rev. 01 — 8 May 2008

Product data sheet

1. Product profile

1.1 General description

The PRTR5V0U4Y is designed to protect Input/Output (I/O) ports that are sensitive to capacitive load, such as USB 2.0, Ethernet and DVI from destruction by ElectroStatic Discharge (ESD). It provides protection to downstream signal and supply components from ESD voltages as high as ± 8 kV (contact discharge).

The PRTR5V0U4Y incorporates four pairs of ultra-low capacitance rail-to-rail diodes plus a Zener diode. The rail-to-rail diodes are connected to the Zener diode which allows ESD protection to be independent of supply voltage. The PRTR5V0U4Y is fabricated using thin film-on-silicon technology integrating four ultra-low capacitance rail-to-rail ESD protection diodes in a miniature 6-lead SOT363 package.

1.2 Features

- Pb-free and RoHS compliant
- ESD protection compliant to IEC 61000-4-2 level 4, ± 8 kV contact discharge
- Four ultra-low input capacitance (1 pF typical) rail-to-rail ESD protection diodes
- Low-voltage clamping due to integrated Zener diode
- Small 6-lead SOT363 package

1.3 Applications

- General-purpose downstream ESD protection high frequency analog signals and high-speed serial data transmission for ports inside:
 - ◆ Cellular and PCS mobile handsets
 - ◆ PC-/notebook USB 2.0/IEEE 1394 ports
 - ◆ DVI/HDMI interfaces
 - ◆ Cordless telephones
 - ◆ Wireless data (WAN/LAN) systems
 - ◆ PDAs

2. Pinning information

Table 1. Pinning

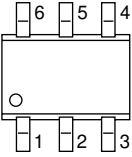
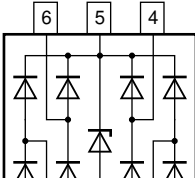
Pin	Description	Simplified outline	Graphic symbol
1	ESD protection I/O 1		
2	ground (GND)		
3	ESD protection I/O 2		
4	ESD protection I/O 3		
5	supply voltage (V _{CC})		
6	ESD protection I/O 4		

001aag273

3. Ordering information

Table 2. Ordering information

Type number	Package		Version
	Name	Description	
PRTR5V0U4Y	SC-88	plastic surface-mounted package; 6 leads	SOT363

4. Limiting values

Table 3. Limiting values

In accordance with the Absolute Maximum Rating System (IEC 60134).

Symbol	Parameter	Conditions	Min	Max	Unit
V _I	input voltage		-0.5	+5.5	V
V _{esd}	electrostatic discharge voltage	all pins; IEC 61000-4-2; level 4			
		contact discharge	-8	+8	kV
		air discharge	-15	+15	kV
T _{stg}	storage temperature		-55	+125	°C

5. Recommended operating conditions

Table 4. Operating conditions

Symbol	Parameter	Conditions	Min	Max	Unit
T _{amb}	ambient temperature		-40	+85	°C

6. Characteristics

Table 5. Characteristics

$T_{amb} = 25\text{ }^{\circ}\text{C}$ unless otherwise specified.

Symbol	Parameter	Conditions	Min	Typ	Max	Unit
$C_{(I/O-GND)}$	input/output to ground capacitance	pins 1, 3, 4 and 6; $V_I = 0\text{ V}$; $f = 1\text{ MHz}$; $V_{CC} = 3.0\text{ V}$	-	1.0	-	pF
I_{LR}	reverse leakage current	pins 1, 3, 4 and 6 to ground; $V_I = 3.0\text{ V}$	-	-	100	nA
V_{BR}	breakdown voltage	Zener diode; $I = 1\text{ mA}$	6	-	9	V
V_F	forward voltage		-	0.7	-	V

7. Application information

7.1 IEEE 1394a/b protection

The PRTR5V0U4Y is optimized to protect both the IEEE 1394 physical layer and the IEEE 1394 connector ports against ESD.

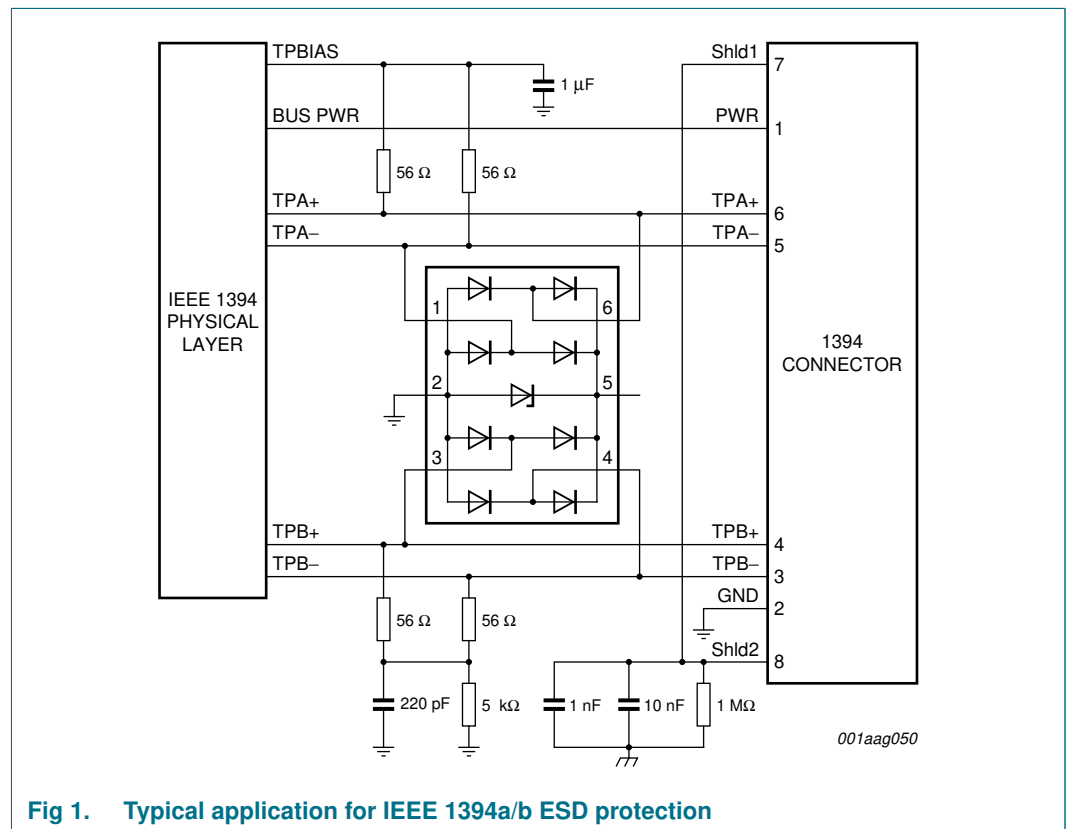
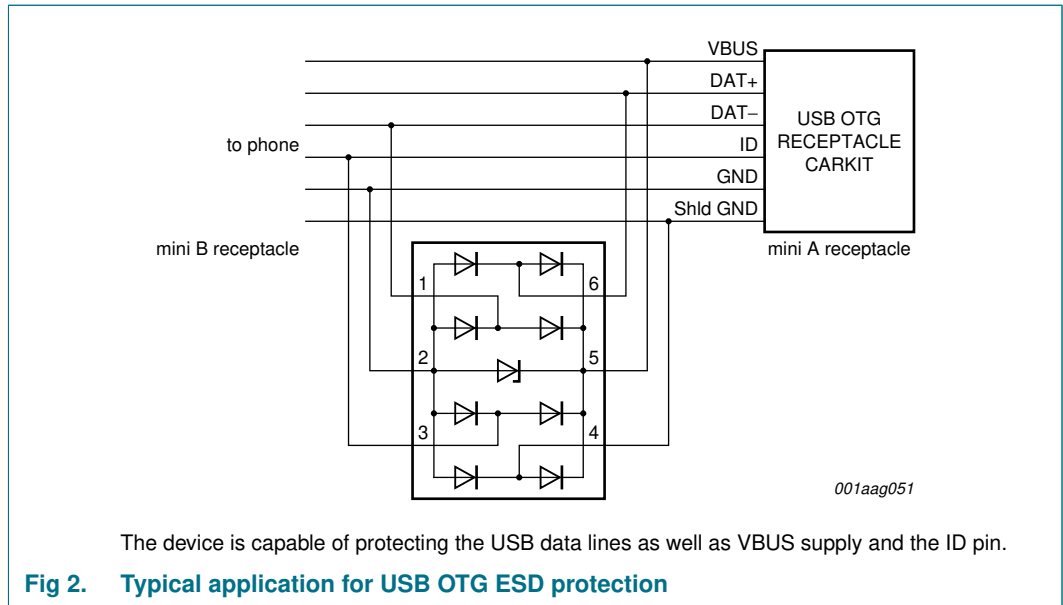

Fig 1. Typical application for IEEE 1394a/b ESD protection

7.2 Universal serial bus 2.0 protection

The PRTR5V0U4Y is optimized to protect USB 2.0 ports with or without OTG functionality against ESD.



7.3 Universal SIM-card protection

The PRTR5V0U4Y protects the SIM-card interfaces against ESD.

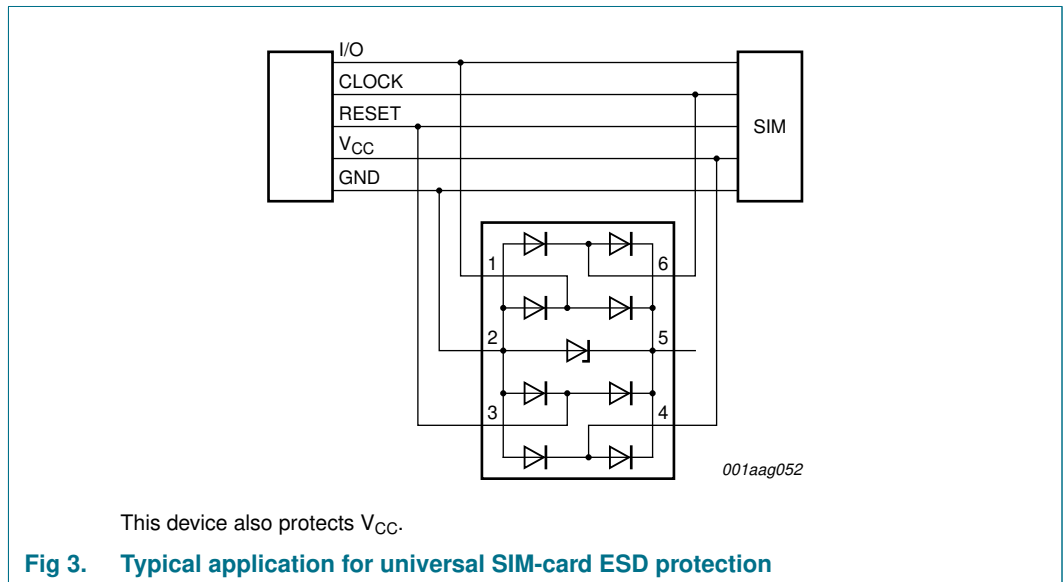

7.4 Gigabit Ethernet transceiver protection

The PRTR5V0U4Y protects the gigabit Ethernet transceiver against ESD.

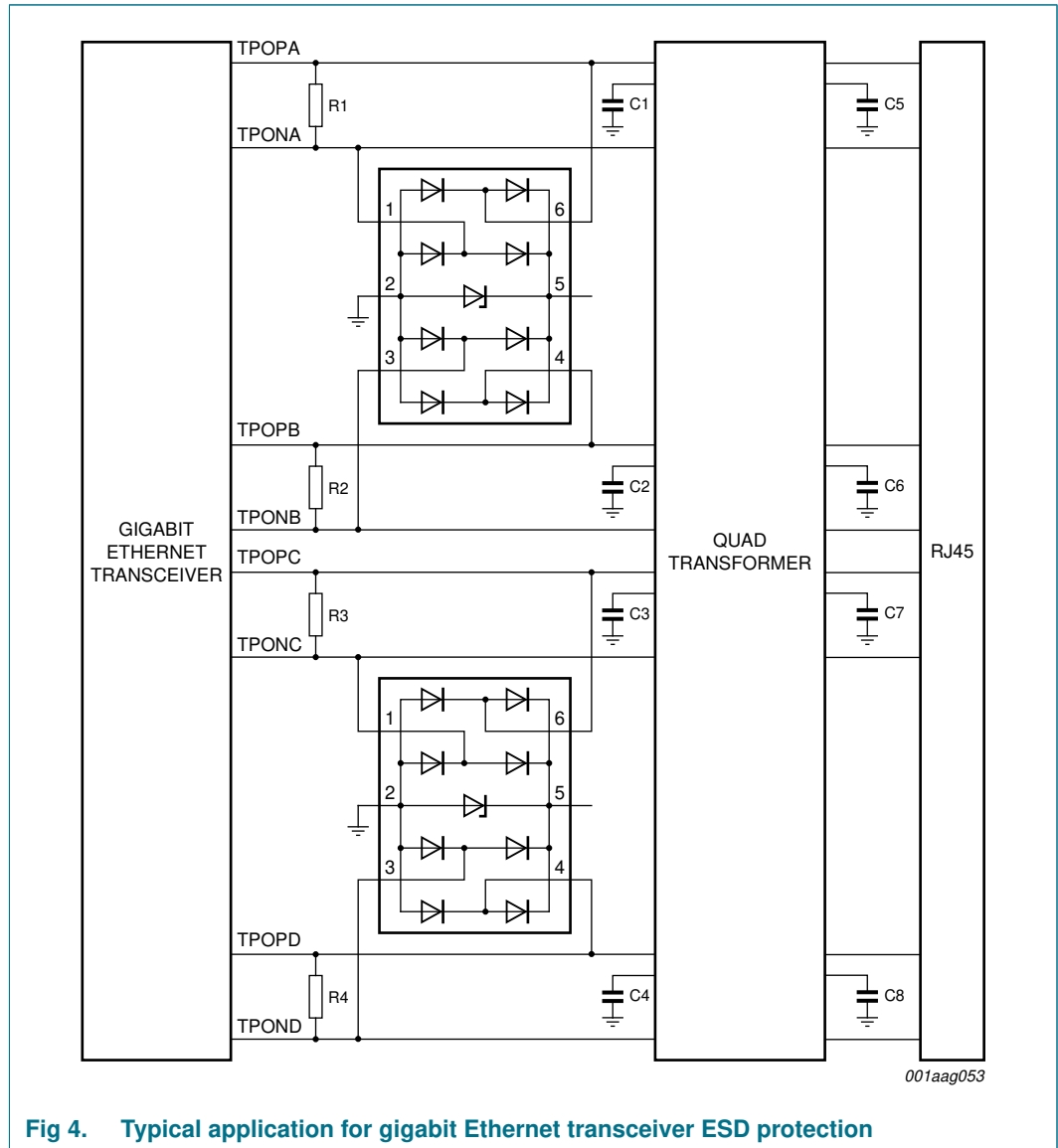
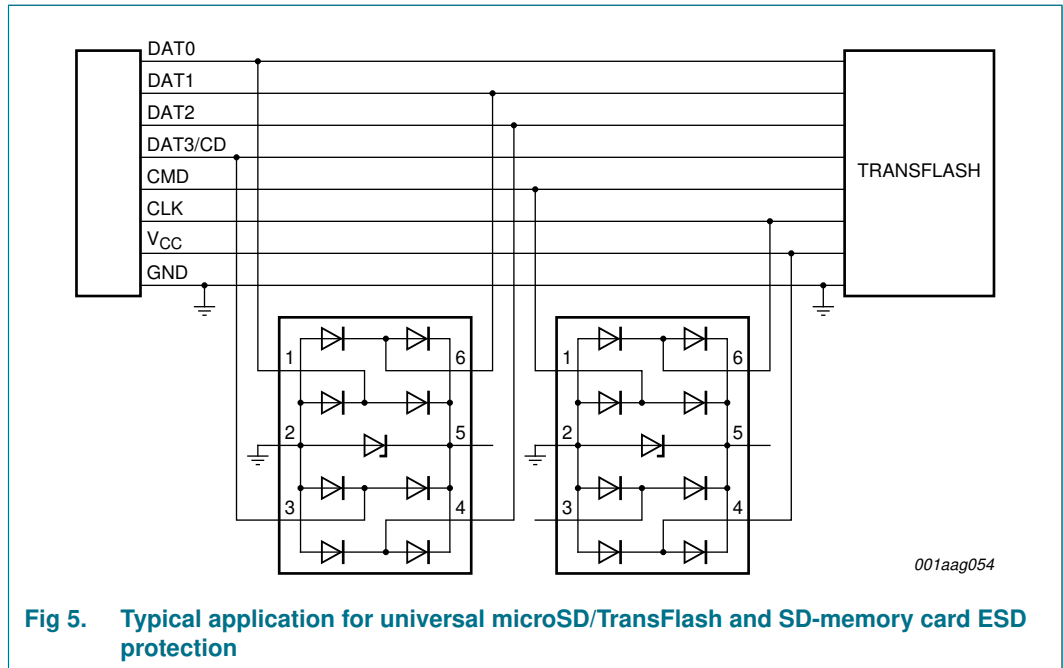

Fig 4. Typical application for gigabit Ethernet transceiver ESD protection

7.5 Universal microSD/TransFlash and SD-memory card protection

The PRTR5V0U4Y protects each data line of the microSD/TransFlash device against ESD.



8. Package outline

Plastic surface-mounted package; 6 leads

SOT363

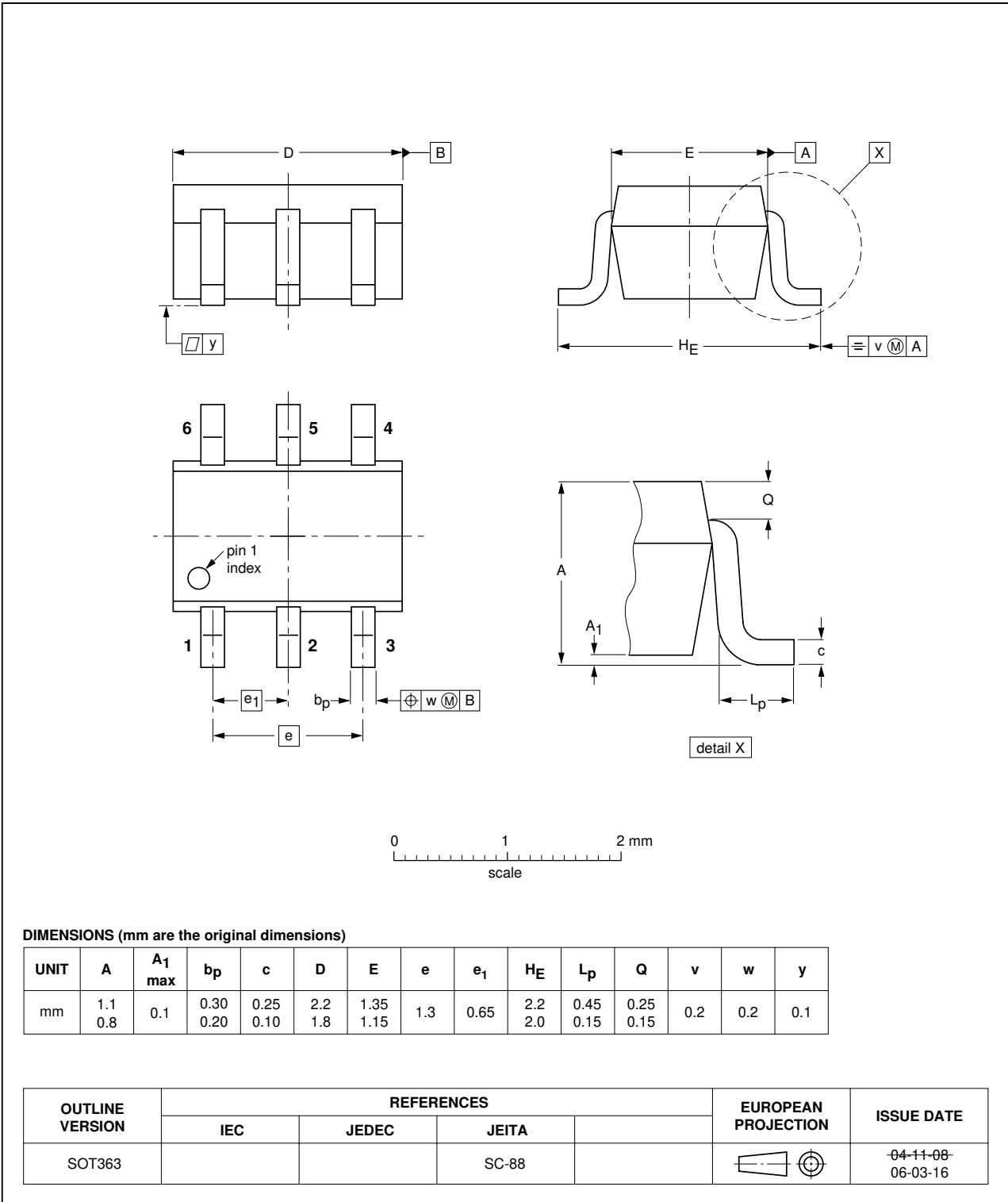

Fig 6. Package outline SOT363 (SC-88)

9. Abbreviations

Table 6. Abbreviations

Acronym	Description
DVI	Digital Video Interface
ESD	ElectroStatic Discharge
HDMI	High Definition Multimedia interface
LAN	Local Area Network
OTG	On-The-Go
PCS	Personal Computing System
PDA	Personal Digital Assistant
RoHS	Restriction of Hazardous Substances
SIM	Subscriber Identity Module
USB	Universal Serial Bus
WAN	Wide Area Network

10. Revision history

Table 7. Revision history

Document ID	Release date	Data sheet status	Change notice	Supersedes
PRTR5V0U4Y_1	20080508	Product data sheet	-	-

11. Legal information

11.1 Data sheet status

Document status ^{[1][2]}	Product status ^[3]	Definition
Objective [short] data sheet	Development	This document contains data from the objective specification for product development.
Preliminary [short] data sheet	Qualification	This document contains data from the preliminary specification.
Product [short] data sheet	Production	This document contains the product specification.

[1] Please consult the most recently issued document before initiating or completing a design.

[2] The term 'short data sheet' is explained in section "Definitions".

[3] The product status of device(s) described in this document may have changed since this document was published and may differ in case of multiple devices. The latest product status information is available on the Internet at URL <http://www.nxp.com>.

11.2 Definitions

Draft — The document is a draft version only. The content is still under internal review and subject to formal approval, which may result in modifications or additions. NXP Semiconductors does not give any representations or warranties as to the accuracy or completeness of information included herein and shall have no liability for the consequences of use of such information.

Short data sheet — A short data sheet is an extract from a full data sheet with the same product type number(s) and title. A short data sheet is intended for quick reference only and should not be relied upon to contain detailed and full information. For detailed and full information see the relevant full data sheet, which is available on request via the local NXP Semiconductors sales office. In case of any inconsistency or conflict with the short data sheet, the full data sheet shall prevail.

11.3 Disclaimers

General — Information in this document is believed to be accurate and reliable. However, NXP Semiconductors does not give any representations or warranties, expressed or implied, as to the accuracy or completeness of such information and shall have no liability for the consequences of use of such information.

Right to make changes — NXP Semiconductors reserves the right to make changes to information published in this document, including without limitation specifications and product descriptions, at any time and without notice. This document supersedes and replaces all information supplied prior to the publication hereof.

Suitability for use — NXP Semiconductors products are not designed, authorized or warranted to be suitable for use in medical, military, aircraft, space or life support equipment, nor in applications where failure or

malfunction of an NXP Semiconductors product can reasonably be expected to result in personal injury, death or severe property or environmental damage. NXP Semiconductors accepts no liability for inclusion and/or use of NXP Semiconductors products in such equipment or applications and therefore such inclusion and/or use is at the customer's own risk.

Applications — Applications that are described herein for any of these products are for illustrative purposes only. NXP Semiconductors makes no representation or warranty that such applications will be suitable for the specified use without further testing or modification.

Limiting values — Stress above one or more limiting values (as defined in the Absolute Maximum Ratings System of IEC 60134) may cause permanent damage to the device. Limiting values are stress ratings only and operation of the device at these or any other conditions above those given in the Characteristics sections of this document is not implied. Exposure to limiting values for extended periods may affect device reliability.

Terms and conditions of sale — NXP Semiconductors products are sold subject to the general terms and conditions of commercial sale, as published at <http://www.nxp.com/profile/terms>, including those pertaining to warranty, intellectual property rights infringement and limitation of liability, unless explicitly otherwise agreed to in writing by NXP Semiconductors. In case of any inconsistency or conflict between information in this document and such terms and conditions, the latter will prevail.

No offer to sell or license — Nothing in this document may be interpreted or construed as an offer to sell products that is open for acceptance or the grant, conveyance or implication of any license under any copyrights, patents or other industrial or intellectual property rights.

11.4 Trademarks

Notice: All referenced brands, product names, service names and trademarks are the property of their respective owners.

12. Contact information

For more information, please visit: <http://www.nxp.com>

For sales office addresses, please send an email to: salesaddresses@nxp.com

13. Contents

1	Product profile	1
1.1	General description	1
1.2	Features	1
1.3	Applications	1
2	Pinning information	2
3	Ordering information	2
4	Limiting values	2
5	Recommended operating conditions	2
6	Characteristics	3
7	Application information	3
7.1	IEEE 1394a/b protection	3
7.2	Universal serial bus 2.0 protection	4
7.3	Universal SIM-card protection	4
7.4	Gigabit Ethernet transceiver protection	5
7.5	Universal microSD/TransFlash and SD-memory card protection	6
8	Package outline	7
9	Abbreviations	8
10	Revision history	8
11	Legal information	9
11.1	Data sheet status	9
11.2	Definitions	9
11.3	Disclaimers	9
11.4	Trademarks	9
12	Contact information	9
13	Contents	10

Please be aware that important notices concerning this document and the product(s) described herein, have been included in section 'Legal information'.



© NXP B.V. 2008.

All rights reserved.

For more information, please visit: <http://www.nxp.com>

For sales office addresses, please send an email to: salesaddresses@nxp.com

Date of release: 8 May 2008

Document identifier: PRTR5V0U4Y_1