



Chipsmall Limited consists of a professional team with an average of over 10 year of expertise in the distribution of electronic components. Based in Hongkong, we have already established firm and mutual-benefit business relationships with customers from,Europe,America and south Asia,supplying obsolete and hard-to-find components to meet their specific needs.

With the principle of "Quality Parts,Customers Priority,Honest Operation,and Considerate Service",our business mainly focus on the distribution of electronic components. Line cards we deal with include Microchip,ALPS,ROHM,Xilinx,Pulse,ON,Everlight and Freescale. Main products comprise IC,Modules,Potentiometer,IC Socket,Relay,Connector.Our parts cover such applications as commercial,industrial, and automotives areas.

We are looking forward to setting up business relationship with you and hope to provide you with the best service and solution. Let us make a better world for our industry!



Contact us

Tel: +86-755-8981 8866 Fax: +86-755-8427 6832

Email & Skype: info@chipsmall.com Web: www.chipsmall.com

Address: A1208, Overseas Decoration Building, #122 Zhenhua RD., Futian, Shenzhen, China



Intellimod™ Module Dual-In-Line Intelligent Power Module 20 Amperes/600 Volts

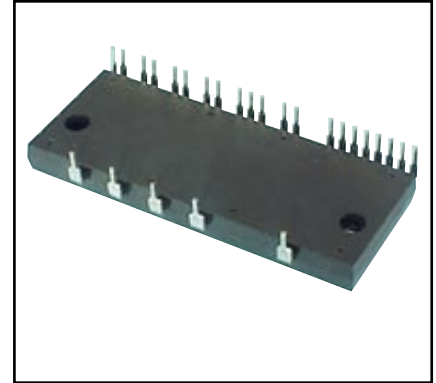
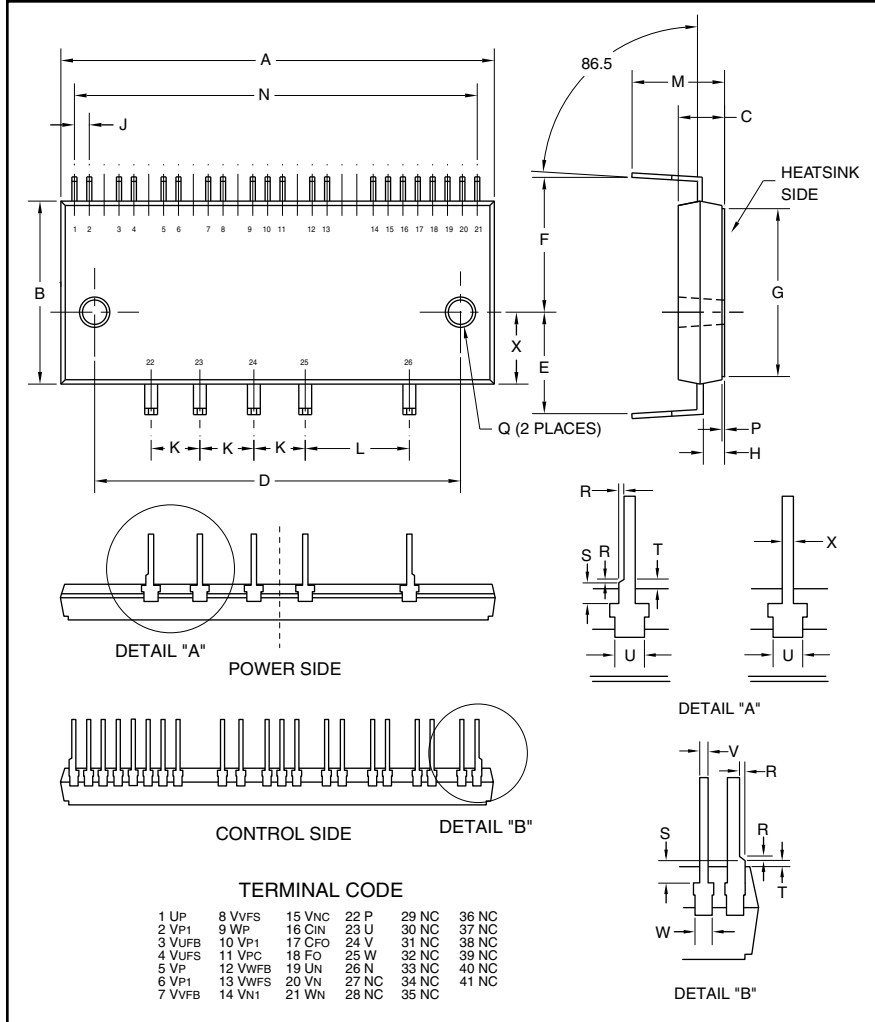

Description:

DIP and mini-DIP IPMs are intelligent power modules that integrate power devices, drivers, and protection circuitry in an ultra compact dual-in-line transfer-mold package for use in driving small three phase motors. Use of 4th generation IGBTs, DIP packaging, and application specific HVICs allow the designer to reduce inverter size and overall design time.

Features:

- Compact Packages
- Single Power Supply
- Integrated HVICs
- Direct Connection to CPU

Applications:

- Washing Machines
- Refrigerators
- Air Conditioners
- Small Servo Motors
- Small Motor Control

Ordering Information:

PS21245-EP is a 600V, 20 Ampere DIP Intelligent Power Module. Note: P suffix designates lead-free leadframe.

Outline Drawing and Circuit Diagram

Dimensions	Inches	Millimeters
A	3.07±0.02	79.0±0.5
B	1.22±0.02	31.0±0.5
C	0.32±0.02	8.0±0.5
D	2.64±0.01	67.0±0.3
E	0.53±0.01 Dia.	13.4±0.2 Dia.
F	0.84±0.02	21.4±0.5
G	1.10±0.02	28.0±0.5
H	0.15±0.01	3.8±0.2
J	0.11±0.01	2.8±0.3
K	0.39±0.01	10.0±0.3
L	0.79±0.01	20.0±0.3

Dimensions	Inches	Millimeters
M	0.50±0.04	12.8±1.0
N	2.98	75.6
P	0.02±0.01	0.5±0.2
Q	0.18±0.01 Dia.	4.5±0.2 Dia.
R	0.02 Max.	0.5 Max.
S	0.08	2.0
T	0.03±0.002	0.6±0.05
U	0.1	2.5
V	0.03±0.01	0.8±0.2
W	0.07	1.75 Max.
X	0.4±0.01	1.0±0.2

PS21245-EP
Intellimod™ Module
Dual-In-Line Intelligent Power Module
 20 Amperes/600 Volts

Absolute Maximum Ratings, $T_j = 25^\circ\text{C}$ unless otherwise specified

Characteristics	Symbol	PS21245-EP	Units
Power Device Junction Temperature*	T_j	-20 to 150	$^\circ\text{C}$
Storage Temperature	T_{stg}	-40 to 125	$^\circ\text{C}$
Case Operating Temperature (See T_C Measure Point Illustration)	T_C	-20 to 100	$^\circ\text{C}$
Mounting Torque, M4 Mounting Screws	—	13	in-lb
Module Weight (Typical)	—	54	Grams
Heatsink Flatness	—	-50 to 100	μm
Self-protection Supply Voltage Limit (Short Circuit Protection Capability)**	$V_{\text{CC(prot.)}}$	400	Volts
Isolation Voltage, AC 1 minute, 60Hz Sinusoidal, Connection Pins to Heatsink Plate	V_{ISO}	2500	Volts

*The maximum junction temperature rating of the power chips integrated within the DIP-IPM is 150°C ($@T_C \leq 100^\circ\text{C}$). However, to ensure safe operation of the DIP-IPM, the average junction temperature should be limited to $T_{j(\text{avg})} \leq 125^\circ\text{C}$ ($@T_C \leq 100^\circ\text{C}$).

** $V_D = V_{\text{DB}} = 13.5 \sim 16.5\text{V}$, Inverter Part, $T_j = 125^\circ\text{C}$, Non-repetitive, Less than $2\mu\text{s}$

IGBT Inverter Sector

Collector-Emitter Voltage	V_{CES}	600	Volts
Collector Current, \pm ($T_C = 25^\circ\text{C}$)	I_C	20	Amperes
Peak Collector Current, \pm ($T_C = 25^\circ\text{C}$, Instantaneous Value (Pulse))	I_{CP}	40	Amperes
Supply Voltage (Applied between P - N)	V_{CC}	450	Volts
Supply Voltage, Surge (Applied between P - N)	$V_{\text{CC(surge)}}$	500	Volts
Collector Dissipation ($T_C = 25^\circ\text{C}$, per 1 Chip)	P_C	56	Watts

Control Sector

Supply Voltage (Applied between $V_{\text{P1-VPC}}$, $V_{\text{N1-VNC}}$)	V_D	20	Volts
Supply Voltage (Applied between $V_{\text{UFB-VUFS}}$, $V_{\text{VFB-VVFS}}$, $V_{\text{WFB-VWFS}}$)	V_{DB}	20	Volts
Input Voltage (Applied between U_P , V_P , W_P - V_{PC} , U_N , V_N , W_N - V_{NC})	V_{CIN}	-0.5 ~ 5.5	Volts
Fault Output Supply Voltage (Applied between F_O - V_{NC})	V_{FO}	-0.5 ~ $V_D+0.5$	Volts
Fault Output Current (Sink Current at F_O Terminal)	I_{FO}	15	mA
Current Sensing Input Voltage (Applied between C_{IN} - V_{NC})	V_{SC}	-0.5 ~ $V_D+0.5$	Volts

PS21245-EP
Intellimod™ Module
Dual-In-Line Intelligent Power Module
 20 Amperes/600 Volts

Electrical and Mechanical Characteristics, $T_j = 25^\circ\text{C}$ unless otherwise specified

Characteristics	Symbol	Test Conditions	Min.	Typ.	Max.	Units
IGBT Inverter Sector						
Collector Cutoff Current	I_{CES}	$V_{CE} = V_{CES}, T_j = 25^\circ\text{C}$	—	—	1.0	mA
		$V_{CE} = V_{CES}, T_j = 125^\circ\text{C}$	—	—	10	mA
Diode Forward Voltage	V_{EC}	$T_j = 25^\circ\text{C}, -I_C = 20\text{A}, V_{CIN} = 5\text{V}$	—	2.2	3.0	Volts
Collector-Emitter Saturation Voltage	$V_{CE(sat)}$	$I_C = 20\text{A}, T_j = 25^\circ\text{C}, V_D = V_{DB} = 15\text{V}, V_{CIN} = 0\text{V}$	—	1.55	2.15	Volts
		$I_C = 20\text{A}, T_j = 125^\circ\text{C}, V_D = V_{DB} = 15\text{V}, V_{CIN} = 0\text{V}$	—	1.65	2.25	Volts
Inductive Load Switching Times	t_{on}	$V_{CC} = 300\text{V}, V_D = 15\text{V},$	0.1	0.8	1.3	μS
	t_{rr}	$I_C = 20\text{A}, T_j = 125^\circ\text{C}, V_{CIN} = 5\text{V(off)}, 0\text{V(on)},$	—	0.1	—	μS
	$t_{C(on)}$	Inductive Load (Upper-Lower Arm),	—	0.5	0.9	μS
	t_{off}	Note: t_{on}, t_{off} includes delay time of	—	1.5	2.7	μS
	$t_{C(off)}$	the internal control circuit.	—	1.0	1.9	μS

T_C Measure Point

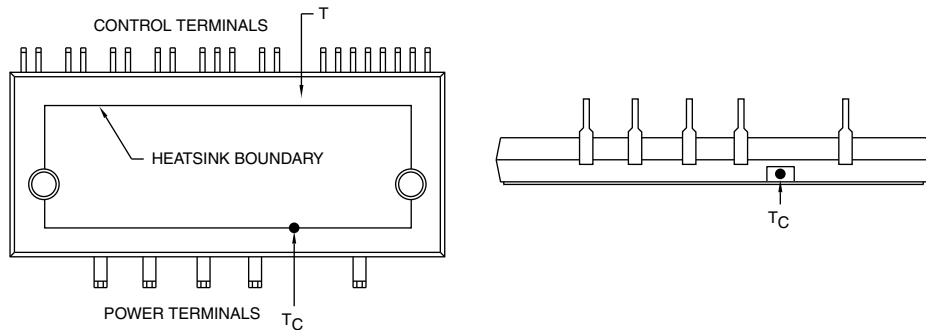

PS21245-EP
Intellimod™ Module
Dual-In-Line Intelligent Power Module
 20 Amperes/600 Volts

Electrical and Mechanical Characteristics, $T_j = 25^\circ\text{C}$ unless otherwise specified

Characteristics	Symbol	Test Conditions	Min.	Typ.	Max.	Units
Control Sector						
Supply Voltage	V_D	Applied between V_{P1} - V_{PC} , V_{N1} - V_{NC}	13.5	15.0	16.5	Volts
	V_{DB}	Applied between V_{UFB} - V_{UFS} , V_{VFB} - V_{VFS} , V_{WFB} - V_{WFS}	13.5	15.0	16.5	Volts
Circuit Current	I_D	$V_D = 15\text{V}$, $V_{CIN} = 5\text{V}$, $V_{DB} = 15\text{V}$, Total of V_{P1} - V_{PC} , V_{N1} - V_{NC}	—	4.25	8.50	mA
		$V_D = 15\text{V}$, $V_{CIN} = 5\text{V}$, $V_{DB} = 15\text{V}$, V_{UFB} - V_{UFS} , V_{VFB} - V_{VFS} , V_{WFB} - V_{WFS}	—	0.50	1.00	mA
Fault Output Voltage	V_{FOH}	$V_{SC} = 0\text{V}$, F_O Circuit: 10k Ω to 5V Pull-up	4.9	—	—	Volts
	V_{FOL}	$V_{SC} = 1\text{V}$, F_O Circuit: 10k Ω to 5V Pull-up	—	0.8	1.2	Volts
	$V_{FO(sat)}$	$V_{SC} = 1\text{V}$, $I_{FO} = 15\text{mA}$	0.8	1.2	1.8	Volts
PWM Input Frequency	f_{PWM}	$T_C \leq 100^\circ\text{C}$, $T_j \leq 125^\circ\text{C}$	—	15	—	kHz
Allowable Dead Time	t_{DEAD}	Relates to Corresponding Input Signal for Blocking Arm Shoot-through ($-20^\circ\text{C} \leq T_C \leq 100^\circ\text{C}$)	2.5	—	—	μs
Short Circuit Trip Level*	$V_{SC(ref)}$	$T_j = 25^\circ\text{C}$, $V_D = 15\text{V}^*$	0.45	0.5	0.55	Volts
Supply Circuit Under-voltage	UV_{DBt}	Trip Level, $T_j \leq 125^\circ\text{C}$	10.0	—	12.0	Volts
	UV_{DBr}	Reset Level, $T_j \leq 125^\circ\text{C}$	10.5	—	12.5	Volts
	UV_{Dt}	Trip Level, $T_j \leq 125^\circ\text{C}$	10.3	—	12.5	Volts
	UV_{Dr}	Reset Level, $T_j \leq 125^\circ\text{C}$	10.8	—	13.0	Volts
Fault Output Pulse Width**	t_{FO}	$C_{FO} = 22\text{nF}$	1.0	1.8	—	mS
ON Threshold Voltage (H-side)	$V_{th(on)}$	Applied between U_P , V_P , W_P - V_{PC}	0.8	1.4	2.0	Volts
OFF Threshold Voltage (H-side)	$V_{th(off)}$	U_P , V_P , W_P - V_{PC}	2.5	3.0	4.0	Volts
ON Threshold Voltage (L-side)	$V_{th(on)}$	Applied between U_N , V_N , W_N - V_{NC}	0.8	1.4	2.0	Volts
OFF Threshold Voltage (L-side)	$V_{th(off)}$	U_N , V_N , W_N - V_{NC}	2.5	3.0	4.0	Volts

* Short Circuit protection is functioning only at the low-arms. Please select the value of the external shunt resistor such that the SC trip level is less than 25.5A.

**Fault signal is asserted when the low-arm short circuit or control supply under-voltage protective functions operate. The fault output pulse-width t_{FO} depends on the capacitance value of C_{FO} according to the following approximate equation: $C_{FO} = (12.2 \times 10^{-6}) \times t_{FO} \{F\}$.



Powerex, Inc., 200 Hillis Street, Youngwood, Pennsylvania 15697-1800 (724) 925-7272

PS21245-EP
Intellimod™ Module
Dual-In-Line Intelligent Power Module
 20 Amperes/600 Volts

Thermal Characteristics

Characteristic	Symbol	Condition	Min.	Typ.	Max.	Units
Junction to Case	$R_{th(j-c)Q}$	Each IGBT	—	—	2.2	°C/Watt
	$R_{th(j-c)D}$	Each FWDi	—	—	4.5	°C/Watt
Contact Thermal Resistance	$R_{th(c-f)}$	Case to Fin Per Module. Thermal Grease Applied	—	—	0.067	°C/Watt

Recommended Conditions for Use

Characteristic	Symbol	Condition	Min.	Typ.	Value	Units
Supply Voltage	V_{CC}	Applied between P-N Terminals	0	300	400	Volts
Control Supply Voltage	V_D	Applied between $V_{P1}-V_{PC}$, $V_{N1}-V_{NC}$	13.5	15.0	16.5	Volts
	V_{DB}	Applied between $V_{UFB}-V_{UFS}$, $V_{VFB}-V_{VFS}$, $V_{WFB}-V_{WFS}$	13.5	15.0	16.5	Volts
Control Supply dv/dt	dV_D/dt , dV_{DB}/dt		-1	—	1	V/ μ s
Input ON Voltage	$V_{CIN(on)}$	Applied between U_P , V_P , W_P-V_{PC}			0 ~ 0.65	Volts
Input OFF Voltage	$V_{CIN(off)}$	Applied between U_N , V_N , W_N-V_{NC}			4.0 ~ 5.5	Volts
PWM Input Frequency	f_{PWM}	$T_C \leq 100^\circ\text{C}$, $T_j \leq 125^\circ\text{C}$	—	5	—	kHz
Arm Shoot-through Blocking Time	t_{DEAD}	For Each Input Signal	2.5	—	—	μ S

PS21245-EP
Intellimod™ Module
Dual-In-Line Intelligent Power Module
 20 Amperes/600 Volts

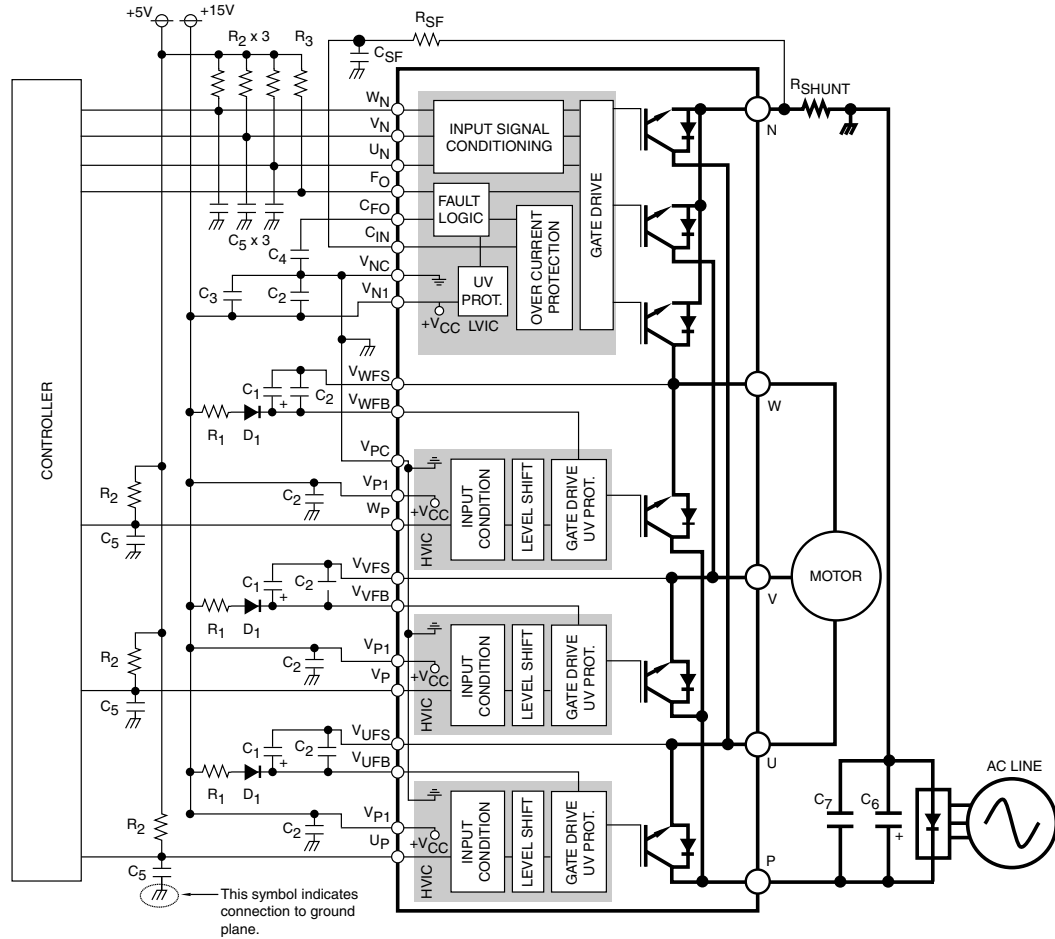

Component Selection:

Dsgn.	Typ. Value	Description
D ₁	1A, 600V	Boot strap supply diode – Ultra fast recovery
C ₁	10-100uF, 50V	Boot strap supply reservoir – Electrolytic, long life, low Impedance, 105°C (Note 5)
C ₂	0.22-2.0uF, 50V	Local decoupling/High frequency noise filters – Multilayer ceramic (Note 8)
C ₃	1-100uF, 50V	Control power supply filter – Electrolytic, long life, low Impedance, 105°C
C ₄	22nF, 50V	Fault lock-out timing capacitor – Multilayer ceramic (Note 4)
C ₅	100-1000pF, 50V	Input signal noise filter – Multilayer ceramic (Note 1)
C ₆	200-2000uF, 450V	Main DC bus filter capacitor – Electrolytic, long life, high ripple current, 105°C
C ₇	0.1-0.22uF, 450V	Surge voltage suppression capacitor – Polyester/Polypropylene film (Note 9)
CSF	1000pF, 50V	Short circuit detection filter capacitor – Multilayer Ceramic (Note 6, Note 7)
RSF	1.8k ohm	Short circuit detection filter resistor (Note 6, Note 7)
RSHUNT	5-100 mohm	Current sensing resistor - Non-inductive, temperature stable, tight tolerance (Note 10)
R ₁	1-100 ohm	Boot strap supply inrush limiting resistor (Note 5)
R ₂	4.7k ohm	Control input pull-up resistor (Note 1, Note 2)
R ₃	5.1k ohm	Fault output signal pull-up resistor (Note 3)

Notes:

- 1) To prevent input signal oscillations minimize wiring length to controller (~2cm). Additional RC filtering (C5 etc.) may be required. If filtering is added be careful to maintain proper dead time. See application notes for details.
- 2) Internal HVIC provides high voltage level shifting allowing direct connection of all six driving signals to the controller.
- 3) F_O output is an open collector type. This signal should be pulled high with 5.1k ohm resistor (R3).
- 4) C4 sets the fault output duration and lock-out time. $C4 = 12.2E^{-6} \times t_{FO} \times t_{FO}$, 22nF gives ~1.8ms
- 5) Boot strap supply component values must be adjusted depending on the PWM frequency and technique.
- 6) Wiring length associated with R_{SHUNT}, R_{SF}, C_{SF} must be minimized to avoid improper operation of the OC function.
- 7) R_{SF}, C_{SF} set over current protection trip time. Recommend time constant is 1.5us-2.0us. See application notes.
- 8) Local decoupling/high frequency filter capacitors must be connected as close as possible to the modules pins.
- 9) The length of the DC link wiring between C6, C7, the DIP's P terminal and the shunt must be minimized to prevent excessive transient voltages. In particular C7 should be mounted as close to the DIP as possible.
- 10) Use high quality, tight tolerance current sensing resistor. Connect resistor as close as possible to the DIP's N terminal. Be careful to check for proper power rating. See application notes for calculation of resistance value.