



Chipsmall Limited consists of a professional team with an average of over 10 year of expertise in the distribution of electronic components. Based in Hongkong, we have already established firm and mutual-benefit business relationships with customers from,Europe,America and south Asia,supplying obsolete and hard-to-find components to meet their specific needs.

With the principle of “Quality Parts,Customers Priority,Honest Operation,and Considerate Service”,our business mainly focus on the distribution of electronic components. Line cards we deal with include Microchip,ALPS,ROHM,Xilinx,Pulse,ON,Everlight and Freescale. Main products comprise IC,Modules,Potentiometer,IC Socket,Relay,Connector.Our parts cover such applications as commercial,industrial, and automotives areas.

We are looking forward to setting up business relationship with you and hope to provide you with the best service and solution. Let us make a better world for our industry!



Contact us

Tel: +86-755-8981 8866 Fax: +86-755-8427 6832

Email & Skype: info@chipsmall.com Web: www.chipsmall.com

Address: A1208, Overseas Decoration Building, #122 Zhenhua RD., Futian, Shenzhen, China



PS21A79

TRANSFER-MOLD TYPE
INSULATED TYPE

PS21A79

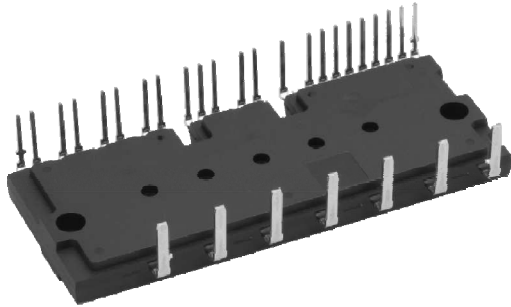

MAIN FUNCTION AND RATINGS

- 3 phase inverter with N-side open emitter structure
- 600V / 50A (CSTBT)

APPLICATION

- AC100 ~ 200Vrms class, motor control

INTEGRATED DRIVE, PROTECTION AND SYSTEM CONTROL FUNCTIONS

- For P-side : Drive circuit, High voltage high-speed level shifting, Control supply under-voltage (UV) protection
- For N-side : Drive circuit, Control supply under-voltage protection (UV), Short circuit protection (SC),
- Fault signaling : Corresponding to SC fault (N-side IGBT), UV fault (N-side supply)
- Temperature monitoring : Analog output of LVIC temperature
- Input interface : 3, 5V line, Schmitt trigger receiver circuit (High Active)
- UL Approved : File No. E80276

MAXIMUM RATINGS (T_j = 25°C, unless otherwise noted)

INVERTER PART

Symbol	Parameter	Condition	Ratings	Unit
V _{CC}	Supply voltage	Applied between P-NU, NV, NW	450	V
V _{CC(surge)}	Supply voltage (surge)	Applied between P-NU, NV, NW	500	V
V _{CES}	Collector-emitter voltage		600	V
±I _C	Each IGBT collector current	T _C = 25°C	50	A
±I _{CP}	Each IGBT collector current (peak)	T _C = 25°C, less than 1ms	100	A
P _C	Collector dissipation	T _C = 25°C, per 1 chip	142	W
T _j	Junction temperature		-20~+150	°C

CONTROL (PROTECTION) PART

Symbol	Parameter	Condition	Ratings	Unit
V _D	Control supply voltage	Applied between V _{P1} -V _{PC} , V _{N1} -V _{NC}	20	V
V _{DB}	Control supply voltage	Applied between V _{UFB} -V _{UFS} , V _{VFB} -V _{VFS} , V _{WFB} -V _{WFS}	20	V
V _{IN}	Input voltage	Applied between U _P , V _P , W _P -V _{PC} , U _N , V _N , W _N -V _{NC}	-0.5~V _D +0.5	V
V _{FO}	Fault output supply voltage	Applied between F _O -V _{NC}	-0.5~V _D +0.5	V
I _{FO}	Fault output current	Sink current at F _O terminal	1	mA
V _{SC}	Current sensing input voltage	Applied between C _{IN} -V _{NC}	-0.5~V _D +0.5	V

TOTAL SYSTEM

Symbol	Parameter	Condition	Ratings	Unit
V _{CC(PROT)}	Self protection supply voltage limit (Short circuit protection capability)	V _D = 13.5~16.5V, Inverter Part T _j = 125°C, non-repetitive, less than 2μs	400	V
T _C	Module case operation temperature	(Note 1)	-20~+100	°C
T _{stg}	Storage temperature		-40~+125	°C
V _{iso}	Isolation voltage	60Hz, Sinusoidal, AC 1minute, between connected all pins and heat-sink plate	2500	V _{rms}

Note 1: T_C measurement point is described in Fig.1.

THERMAL RESISTANCE

Symbol	Parameter	Condition	Limits			Unit
			Min.	Typ.	Max.	
R _{th(j-c)Q}	Junction to case thermal resistance (Note 2)	Inverter IGBT part (per 1/6 module)	-	-	0.88	°C/W
R _{th(j-c)F}		Inverter FWDi part (per 1/6 module)	-	-	1.78	°C/W

Note 2: Grease with good thermal conductivity and long-term endurance should be applied evenly with about +100μm~+200μm on the contacting surface of DIPIPM and heat-sink. The contacting thermal resistance between DIPIPM case and heat sink R_{th(c-f)} is determined by the thickness and the thermal conductivity of the applied grease. For reference, R_{th(c-f)} is about 0.2°C/W (per 1/6 module, grease thickness: 20μm, thermal conductivity: 1.0W/m·k).

Fig. 1: T_c MEASUREMENT POINT

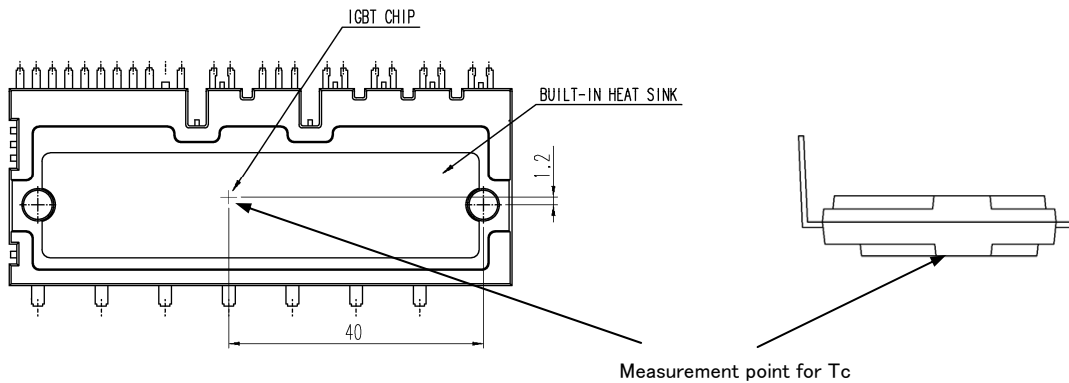

ELECTRICAL CHARACTERISTICS (T_j = 25°C, unless otherwise noted)
INVERTER PART

Symbol	Parameter	Condition	Limits			Unit	
			Min.	Typ.	Max.		
V _{CE(sat)}	Collector-emitter saturation voltage	V _D =V _{DB} = 15V V _{IN} = 5V, I _C = 50A	T _j = 25°C T _j = 125°C	- -	1.55 1.65	2.05 2.10	V
V _{EC}	FWDi forward voltage	-I _C = 50A, V _{IN} = 0V		-	1.70	2.20	V
t _{on}	Switching times	V _{CC} = 300V, V _D = V _{DB} = 15V I _C = 50A, T _j = 125°C, V _{IN} = 0→5 V Inductive Load (upper-lower arm)		1.80	2.40	3.60	μs
t _{C(on)}				-	0.40	0.60	μs
t _{off}				-	3.00	4.20	μs
t _{C(off)}				-	0.60	1.20	μs
t _{rr}				-	0.30	-	μs
I _{CES}	Collector-emitter cut-off current	V _{CE} =V _{CES}	T _j = 25°C T _j = 125°C	- -	- -	1 10	mA

CONTROL (PROTECTION) PART

Symbol	Parameter	Condition	Limits			Unit		
			Min.	Typ.	Max.			
I _D	Circuit current	Total of V _{P1} -V _{PC} , V _{N1} -V _{NC}	V _D = 15V, V _{IN} = 0V V _D = 15V, V _{IN} = 5V	- -	- -	5.50 5.50	mA	
I _{DB}	Circuit current	V _{UFB} -V _{UFS} , V _{VFB} -V _{VFS} , V _{WFB} -V _{WFS}	V _D = V _{DB} = 15V, V _{IN} = 0V V _D = V _{DB} = 15V, V _{IN} = 5V	- -	- -	0.55 0.55	mA	
I _{SC}	Short circuit trip level	-20°C≤T _j ≤125°C, R _s = 40.2Ω (±1%), Not connecting outer shunt resistors to NU, NV, NW terminals (Note 3)		85	-	-	A	
UV _{DBt}	Control supply under-voltage protection	T _j ≤125°C	P-side	Trip level	10.0	-	12.0	V
UV _{DBr}				Reset level	10.5	-	12.5	V
UV _{Dt}			N-side	Trip level	10.3	-	12.5	V
UV _{Dr}				Reset level	10.8	-	13.0	V
V _{FOH}	Fault output voltage	V _{SC} = 0V, F _O terminal pull-up to 5V by 10kΩ		4.9	-	-	V	
V _{FOL}		V _{SC} = 1V, I _{FO} = 1mA		-	-	0.95	V	
t _{FO}	Fault output pulse width	C _{FO} =22nF (Note 4)		1.6	2.4	-	ms	
I _{IN}	Input current	V _{IN} = 5V		0.7	1.0	1.5	mA	
V _{th(on)}	ON threshold voltage	Applied between U _P , V _P , W _P -V _{PC} , U _N , V _N , W _N -V _{NC}		2.1	2.3	2.6	V	
V _{th(off)}	OFF threshold voltage			0.8	1.4	2.1	V	
V _{OT}	Temperature output	LVIC temperature = 85°C (Note 5)		3.57	3.63	3.69	V	

Note 3 : Short circuit protection can work for N-side IGBTs only. I_{sc} level can change by sense resistance. For details, please refer the application note for this DIPIPM or contact us. And in that case, it should be for sense resistor to be larger resistance than the value mentioned above.

4 : Fault signal is output when short circuit or N-side control supply under-voltage protective functions operate. The fault output pulse-width t_{FO} depends on the capacitance value of C_{FO}. (C_{FO} (typ.) = t_{FO} x (9.1 x 10⁹) [F])

5 : DIPIPM don't shutdown IGBTs and output fault signal automatically when temperature rises excessively. When temperature exceeds the protective level that user defined, controller (MCU) should stop the DIPIPM. And this output might exceed 5V when temperature rises excessively, so it is recommended for protection of control part like MCU to insert a clamp Di between supply (e.g. 5V) for control part and this output. Temperature of LVIC vs. V_{OT} output characteristics is described in Fig.2

Fig.2 Temperature of LVIC - V_{OT} output characteristics

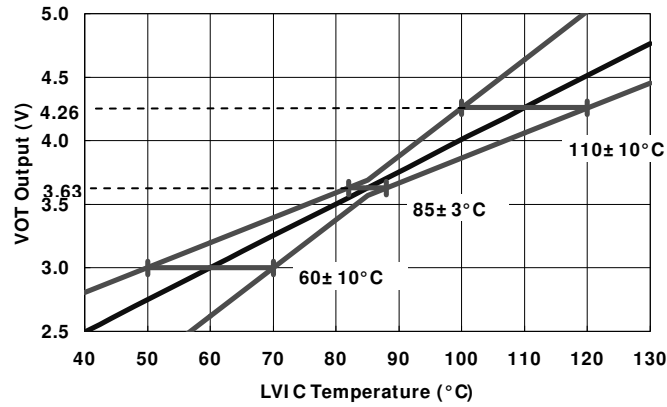

MECHANICAL CHARACTERISTICS AND RATINGS

Parameter	Condition		Limits			Unit	
			Min.	Typ.	Max.		
Mounting torque	Mounting screw : M4	Recommended	1.18N·m	0.98	1.18	1.47	N·m
Terminal pulling strength	Load 19.6N		EIAJ-ED-4701	10	-	-	s
Terminal bending strength	Load 9.8N, 90deg. bend		EIAJ-ED-4701	2	-	-	times
Weight				-	46	-	g
Heat-sink flatness		(Note 6)		-50	-	100	μm

Note 6: Measurement point of heat-sink flatness

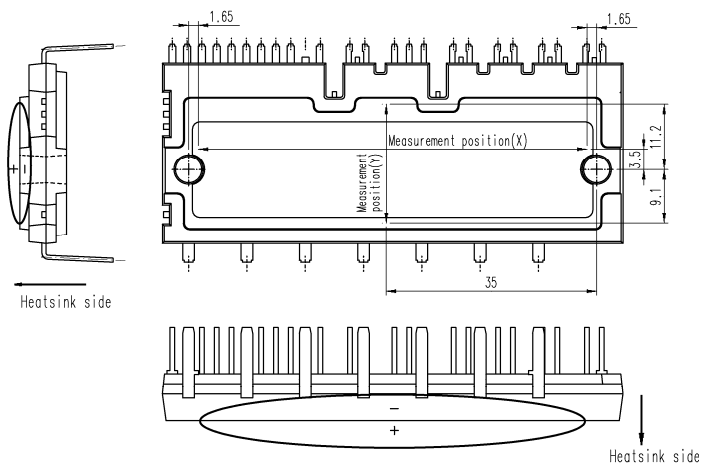

RECOMMENDED OPERATION CONDITIONS

Symbol	Parameter	Condition	Limits			Unit	
			Min.	Typ.	Max.		
V_{CC}	Supply voltage	Applied between P-NU, NV, NW	0	300	400	V	
V_D	Control supply voltage	Applied between $V_{P1}-V_{PC}$, $V_{N1}-V_{NC}$	13.5	15.0	16.5	V	
V_{DB}	Control supply voltage	Applied between $V_{UFB}-V_{UFS}$, $V_{VFB}-V_{VFS}$, $V_{WFB}-V_{WFS}$	13.0	15.0	18.5	V	
$\Delta V_D, \Delta V_{DB}$	Control supply variation		-1	-	+1	V/ μ s	
t_{dead}	Arm shoot-through blocking time	For each input signal, $T_C \leq 100^\circ\text{C}$	2.2	-	-	μ s	
f_{PWM}	PWM input frequency	$T_C \leq 100^\circ\text{C}$, $T_J \leq 125^\circ\text{C}$	-	-	20	kHz	
I_o	Allowable r.m.s. current	$V_{CC} = 300\text{V}$, $V_D = 15\text{V}$, P.F = 0.8, Sinusoidal PWM $T_C \leq 100^\circ\text{C}$, $T_J \leq 125^\circ\text{C}$ (Note 7)	$f_{PWM} = 5\text{kHz}$	-	-	23.6	Arms
			$f_{PWM} = 15\text{kHz}$	-	-	13.8	
PWIN(on)	Minimum input pulse width	$200 \leq V_{CC} \leq 350\text{V}$, $13.5 \leq V_D \leq 16.5\text{V}$, $13.0 \leq V_{DB} \leq 18.5\text{V}$, $-20^\circ\text{C} \leq T_C \leq 100^\circ\text{C}$, N line wiring inductance less than 10nH (Note 9)	(Note 8)	1.1	-	-	μ s
PWIN(off)			$I_C \leq 50\text{A}$	3.0	-	-	
			$50 < I_C \leq 85\text{A}$	5.0	-	-	
V_{NC}	V_{NC} variation	Between $V_{NC}-\text{NU}$, NV, NW (including surge)	-5.0	-	+5.0	V	
T_J	Junction temperature		-20	-	+125	$^\circ\text{C}$	

Note 7: The allowable r.m.s. current value depends on the actual application conditions.

8: DIIPM might not make response to the input on signal with pulse width less than PWIN (on).

9: IPM might make no response or delayed response (at P-side IGBT only) for the input signal with off pulse width less than PWIN(off). Please refer Fig. 3 about delayed response.

Fig. 3 About Delayed Response Against Shorter Input Off Signal Than PWIN(off) (P-side only)

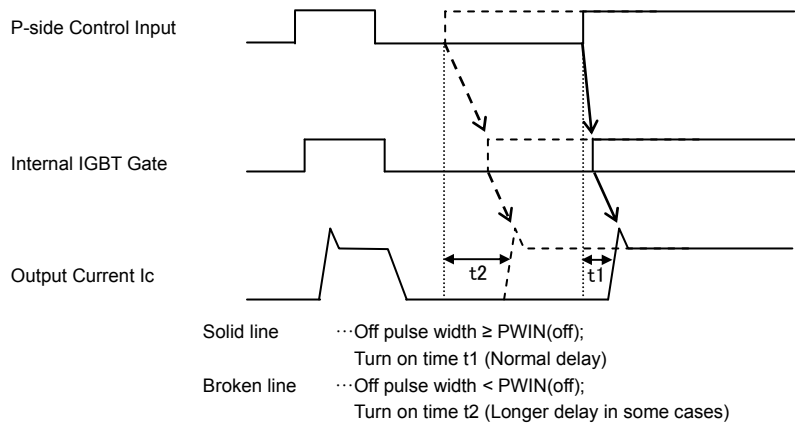

Fig. 4 INTERNAL CIRCUIT

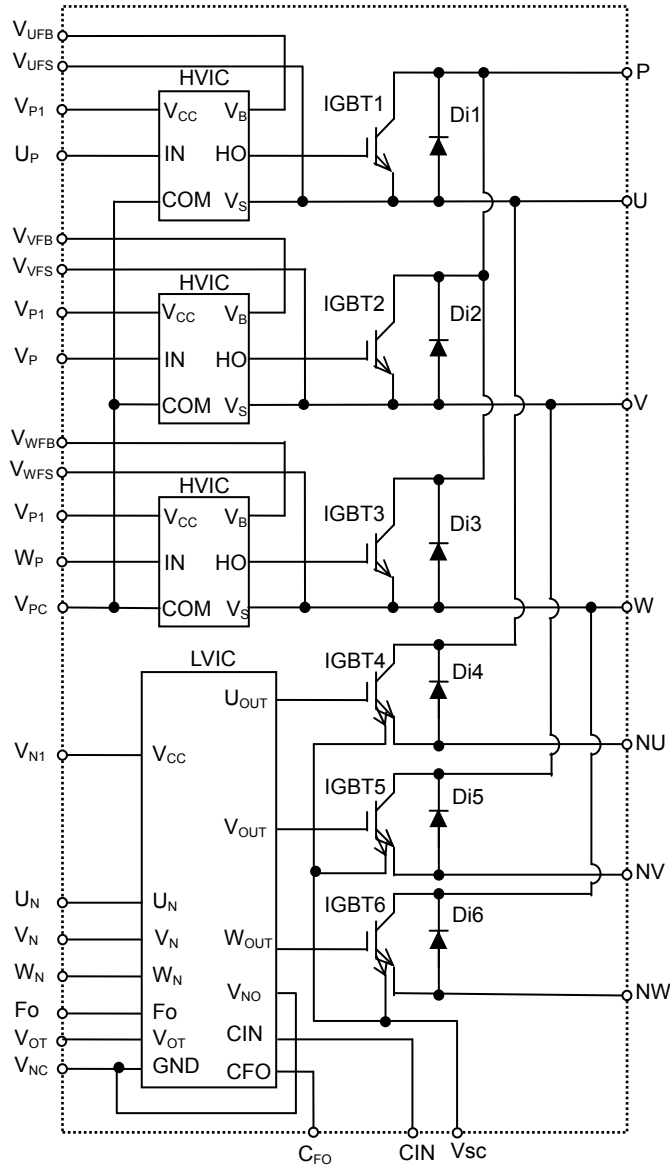
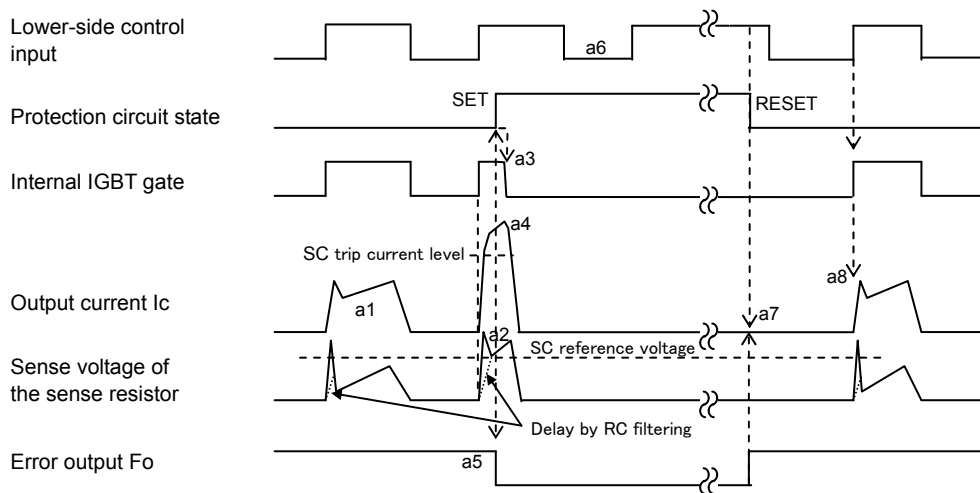

Fig. 5 TIMING CHARTS OF THE DIIPM PROTECTIVE FUNCTIONS

[A] Short-Circuit Protection (N-side only with the external sense resistor and RC filter)

- a1. Normal operation: IGBT ON and outputs current.
- a2. Short circuit current detection (SC trigger) (It is recommended to set RC time constant 1.5~2.0 μ s so that IGBT shut down within 2.0 μ s when SC.)
- a3. All N-side IGBT's gates are hard interrupted.
- a4. All N-side IGBTs turn OFF.
- a5. Fo outputs with a fixed pulse width determined by the external capacitor C_{Fo}.
- a6. Input = "L": IGBT OFF
- a7. Fo finishes output, but IGBTs don't turn on until inputting next ON signal (L→H).
- (IGBT of each phase can return to normal state by inputting ON signal to each phase.)
- a8. Normal operation: IGBT ON and outputs current.



[B] Under-Voltage Protection (N-side, UV_D)

- b1. Control supply voltage V_D exceeds under voltage reset level (UV_{Dr}), but IGBT turns ON when inputting next ON signal (L→H).
(IGBT of each phase can return to normal state by inputting ON signal to each phase.)
- b2. Normal operation: IGBT ON and outputs current.
- b3. V_D level drops to under voltage trip level. (UV_{Dt}).
- b4. All N-side IGBTs turn OFF in spite of control input condition.
- b5. Fo outputs for the period determined by the capacitance C_{Fo}, but output is extended during V_D keeps below UV_{Dr}.
- b6. V_D level reaches UV_{Dr}.
- b7. Normal operation: IGBT ON and outputs current.

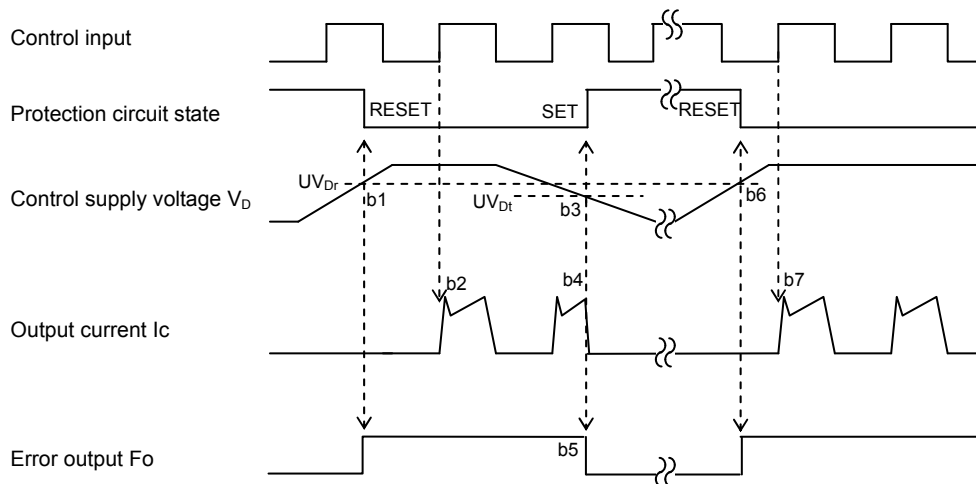

[C] Under-Voltage Protection (P-side, UV_{DB})

- c1. Control supply voltage V_{DB} rises. After the voltage reaches under voltage reset level UV_{DBr} , IGBT can turn on when inputting next ON signal (L→H).
- c2. Normal operation: IGBT ON and outputs current.
- c3. V_{DB} level drops to under voltage trip level (UV_{DBt}).
- c4. IGBT of corresponding phase only turns OFF in spite of control input signal level, but there is no F_o signal output.
- c5. V_{DB} level reaches UV_{DBr} .
- c6. Normal operation: IGBT ON and outputs current.

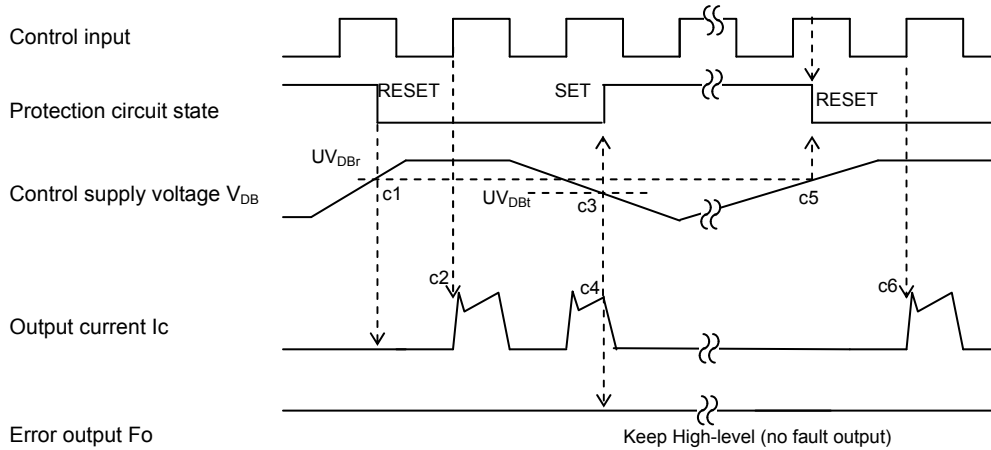
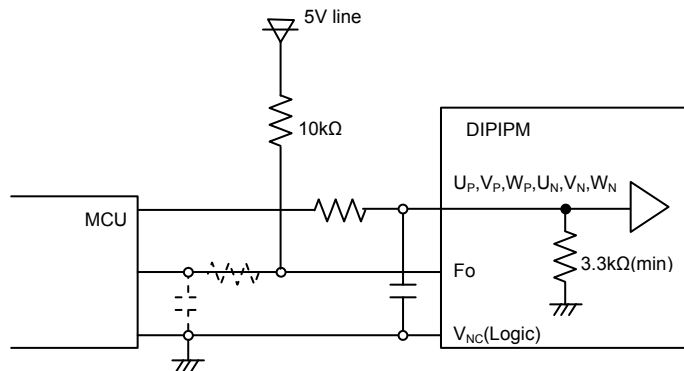

Fig. 6 MCU I/O INTERFACE CIRCUIT



Note)

Design for input RC filter depends on the PWM control scheme used in the application and the wiring impedance of the printed circuit board. The DIPIPM input signal interface integrates a $3.3k\Omega(\text{min})$ pull-down resistor. Therefore, when using RC filter, be careful to satisfy the turn-on threshold voltage requirement.

F_o output is open drain type. It should be pulled up to the positive side of 5V or 15V power supply with the resistor that limits F_o sink current I_{F_o} under 1mA. In the case of pulling up to 5V supply, over $5.1k\Omega$ is needed. ($10k\Omega$ is recommended.)

Fig. 7 AN EXAMPLE OF APPLICATION CIRCUIT

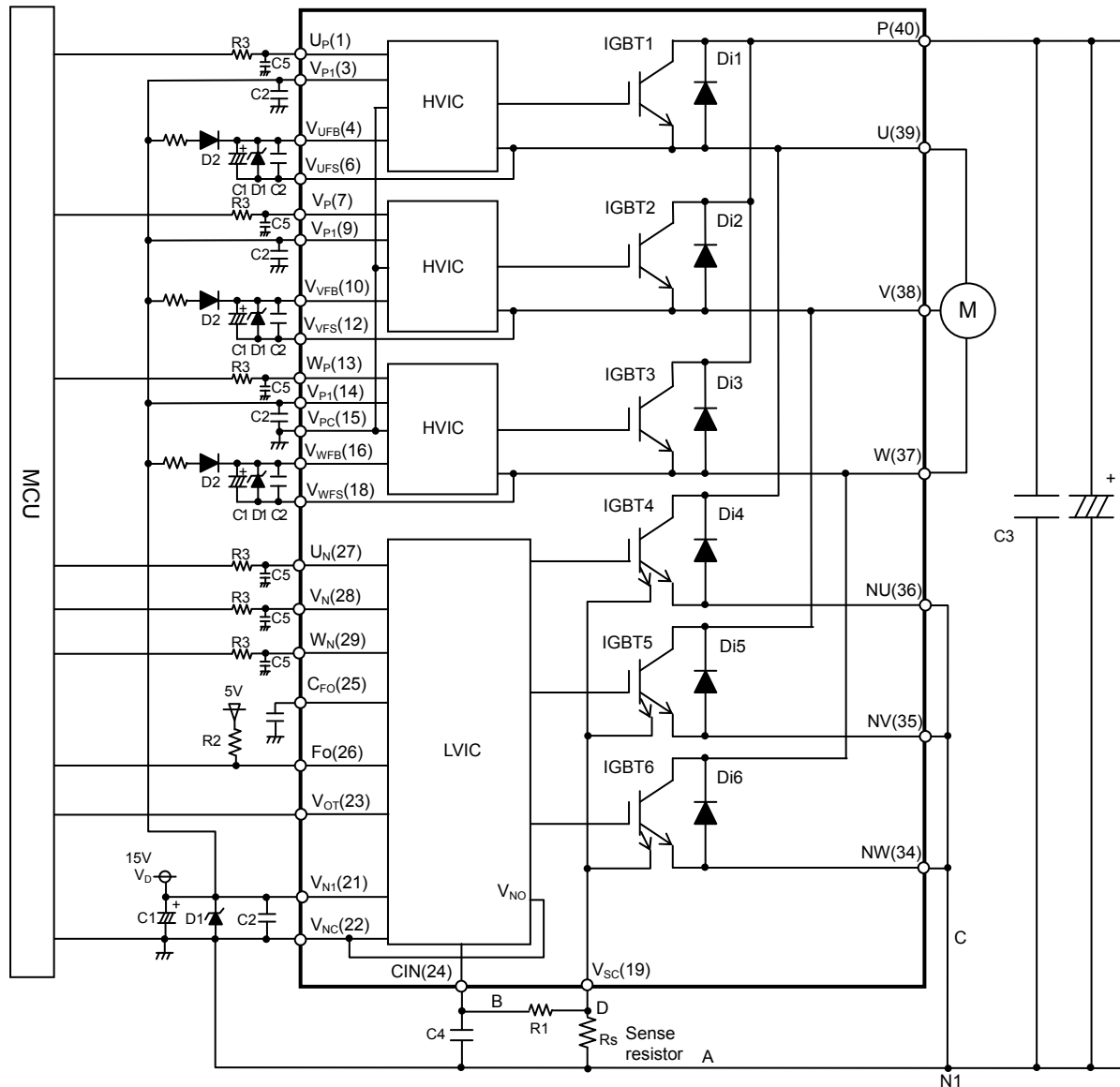

Note

- 1 :If control GND is connected to power GND by broad pattern, it may cause malfunction by power GND fluctuation. It is recommended to connect control GND and power GND at only a point at which NU, NV, NW are connected to power GND line.
- 2 :To prevent surge destruction, the wiring between the smoothing capacitor and the P,N1 terminals should be as short as possible. Generally inserting a 0.1μ~0.22μF snubber capacitor C3 between the P-N1 terminals is recommended.
- 3 :The time constant R1C4 of RC filter for preventing protection circuit malfunction should be selected in the range of 1.5μs~2μs. SC interrupting time might vary with the wiring pattern. Tight tolerance, temp-compensated type is recommended for R1,C4. When R1 is too small, it will leads to delay of protection. So R1 should be min. 10 times larger resistance than Rs. (Over 100 times is recommended.)
- 4 :All capacitors should be mounted as close to the terminals of the DIPIM as possible. (C1: good temperature, frequency characteristic electrolytic type, and C2: 0.22μ~2.0μF, good temperature, frequency and DC bias characteristic ceramic type are recommended.)
- 5 :It is recommended to insert a Zener diode D1 (24V/1W) between each pair of control supply terminals to prevent surge destruction.
- 6 :To prevent erroneous SC protection, the wiring from V_{sc} terminal to CIN filter should be divided at the point D that is close to the terminal of sense resistor. And the wiring should be patterned as short as possible.
- 7 :For sense resistor, the variation within 1%(including temperature characteristics), low inductance type is recommended. And the over 1/8W is recommended, but it is necessary to evaluate in your real system finally.
- 8 :To prevent erroneous operation, the wiring of A, B, C should be as short as possible.
- 9 :Fo output is open drain type. It should be pulled up to the positive side of 5V or 15V power supply with the resistor that limits Fo sink current I_{Fo} under 1mA. In the case pull up to 5V supply, over R2=5.1kΩ is needed. (10kΩ is recommended.)
- 10 :Error signal output width (t_{Fo}) can be set by the capacitor connected to C_{Fo} terminal. C_{Fo}(typ.) = t_{Fo} × (9.1 × 10⁻⁶) (F)
- 11 :High voltage (V_{RRM} =600V or more) and fast recovery type (trr<less than 100ns or less) diode D2 should be used in the bootstrap circuit.
- 12 :If high frequency noise superimposed to the control supply line, IC malfunction might happen and cause erroneous operation. To avoid such problem, voltage ripple of control supply line should meet dV/dt ≤+/-1V/μs, Vripples≤2Vp-p.
- 13 :Input drive is High-Active type. There is a 3.3kΩ(min.) pull-down resistor integrated in the IC input circuit. To prevent malfunction, the wiring of each input should be patterned as short as possible. When using RC filter R3C5, it is necessary to confirm the input signal level to meet the turn-on and turn-off threshold voltage. Thanks to HVIC inside the module, direct coupling to MCU without any opto-coupler or transformer isolation is possible.

PS21A79

TRANSFER-MOLD TYPE
INSULATED TYPE

Fig. 8 PACKAGE OUTLINES

Dimensions in mm

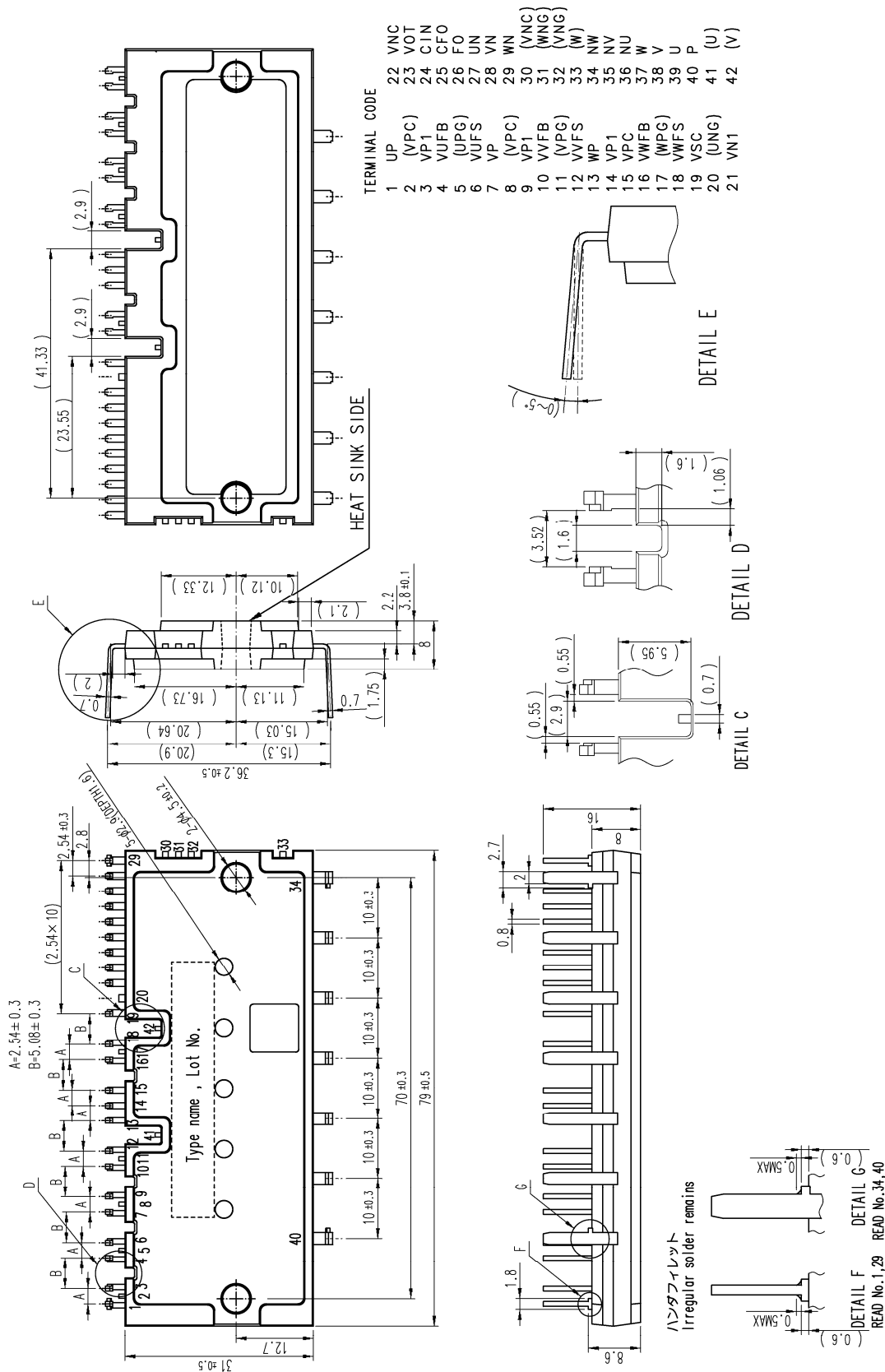

Keep safety first in your circuit designs!

Mitsubishi Electric Corporation puts the maximum effort into making semiconductor products better and more reliable, but these are always the possibility that trouble may occur with them. Trouble with semiconductors may lead to personal injury, fire or property damage. Remember to give due consideration to safety when making your circuit designs, with appropriate measures such as (1) placement of substitutive, auxiliary circuits, (2) use of non-flammable material or (3) prevention against any malfunction or mishap.

Notice regarding these materials

These materials are intended as reference to assist our customers in the selection of the Mitsubishi semiconductor product best suited to the customer's application; they do not convey any license under any intellectual property rights, or any other rights, belonging to Mitsubishi Electric Corporation or third party.

Mitsubishi Electric Corporation assumes no responsibility for any damage, or infringement of any third-party's rights, originating in the use of any product data, diagrams, chart, programs, algorithms, or circuit application examples contained in these materials.

All information contained in these materials, including product data, diagrams, charts, programs and algorithms represents information on products at the time of publication of these materials, and are subject to change by Mitsubishi Electric Corporation without notice due to product improvements or other reasons. It is therefore recommended that customers contact Mitsubishi Electric Corporation or an authorized Mitsubishi Semiconductor product distributor for the latest product information before purchasing a product listed herein. The information described here may contain inaccuracies or typographical errors. Mitsubishi Electric Corporation assumes no responsibility for any damage, liability, or other loss rising from these inaccuracies or errors. Please also pay attention to information published by Mitsubishi Electric Corporation by various means, including the Mitsubishi Semiconductor home page (<http://www.mitsubishichips.com>)

When using any or all of the information contained in these materials, including product data, diagrams, charts, programs and algorithms, please be sure to evaluate all information as a total system before making a final decision on the applicability of the information and products. Mitsubishi Electric Corporation assumes no responsibility for any damage, liability or other loss resulting from the information contained herein.

Mitsubishi Electric Corporation semiconductors are not designed or manufactured for use in a device or system that is used under circumstances in which human life is potentially at stake. Please contact Mitsubishi Electric Corporation or an authorized Mitsubishi Semiconductor product distributor when considering the use of a product contained herein for any specific purposes, such as apparatus or systems for transportation, vehicular, medical, aerospace, nuclear, or undersea repeater use.

The prior written approval of Mitsubishi Electric Corporation is necessary to reprint or reproduce in whole or in part these materials.

If these products or technologies are subject to the Japanese export control restrictions, they must be exported under a license from the Japanese government and cannot be imported into a country other than the approved destination. Any diversion or reexport contrary to the export control laws and regulations of Japan and/or the country of destination is prohibited.

Please contact Mitsubishi Electric Corporation or an authorized Mitsubishi Semiconductor product distributor for further details on these materials or the products contained therein.

DIPIPM and CSTBT are registered trademarks of MITSUBISHI ELECTRIC CORPORATION.