



Chipsmall Limited consists of a professional team with an average of over 10 year of expertise in the distribution of electronic components. Based in Hongkong, we have already established firm and mutual-benefit business relationships with customers from,Europe,America and south Asia,supplying obsolete and hard-to-find components to meet their specific needs.

With the principle of “Quality Parts,Customers Priority,Honest Operation,and Considerate Service”,our business mainly focus on the distribution of electronic components. Line cards we deal with include Microchip,ALPS,ROHM,Xilinx,Pulse,ON,Everlight and Freescale. Main products comprise IC,Modules,Potentiometer,IC Socket,Relay,Connector.Our parts cover such applications as commercial,industrial, and automotives areas.

We are looking forward to setting up business relationship with you and hope to provide you with the best service and solution. Let us make a better world for our industry!



Contact us

Tel: +86-755-8981 8866 Fax: +86-755-8427 6832

Email & Skype: info@chipsmall.com Web: www.chipsmall.com

Address: A1208, Overseas Decoration Building, #122 Zhenhua RD., Futian, Shenzhen, China



FEATURES

- **1 CHANNEL TYPE:**
1a output
- **2 CHANNEL TYPE:**
1a + 1a output
- **DESIGNED FOR AC/DC SWITCHING LINE CHANGER**
- **SMALL PACKAGE:**
6 and 8 pin DIP
- **LOW OFFSET VOLTAGE**
- **LOW LED OPERATING CURRENT:**
 $I_F = 2 \text{ mA}$
- **SURFACE MOUNT AVAILABLE**

DESCRIPTION

PS7122-1A,-2A and PS7122L-1A,-2A are solid state relays containing a GaAs LED on the light emitting side (input side) and MOSFETs on the output side. They are suitable for analog signal control because of their low offset and high linearity.

APPLICATIONS

- **EXCHANGE EQUIPMENT**
- **MEASUREMENT EQUIPMENT**
- **FA/OA EQUIPMENT**

ELECTRICAL CHARACTERISTICS ($T_A = 25 \text{ }^\circ\text{C}$)

PART NUMBER			PS7122-1A,-2A, PS7122L-1A,-2A			
	SYMBOLS	PARAMETERS	UNITS	MIN	TYP	MAX
Diode	V_F	Forward Voltage, $I_F = 10 \text{ mA}$	V		1.2	1.4
	I_R	Reverse Current, $V_R = 5 \text{ V}$	μA			5.0
MOS FET	I_{LOFF}	Off-State Leakage Current, $V_D = 200 \text{ V}$	μA		0.03	1.0
	C_{out}	Output Capacitance, $V_D = 0 \text{ V}$, $f = 1 \text{ MHz}$	pF/ch		165	
Coupled	I_{Fon}	LED On-state Current, $I_L = 200 \text{ mA}$	mA			2.0
	R_{ON1}	On-State Resistance, $I_F = 10 \text{ mA}$, $I_L = 10 \text{ mA}$	Ω		3.0	5.0
	R_{ON2}					
	t_{ON}	Turn-on Time ¹ $I_F = 10 \text{ mA}$, $V_L = 5 \text{ V}$, $R_L = 500 \Omega$, $PW \geq 10 \text{ ms}$	ms		0.6	2.0
	t_{OFF}	Turn-off Time ¹ $I_F = 10 \text{ mA}$, $V_L = 5 \text{ V}$, $R_L = 500 \Omega$, $PW \geq 10 \text{ ms}$	ms		0.06	0.2
	Ri-o	Isolation Resistance, $V_{i-o} = 1.0 \text{ kVdc}$	Ω		10^9	
	Cl-o	Isolation Capacitance, $V = 0 \text{ V}$, $f = 1 \text{ MHz}$	pF/ch		1.1	

Note:

1. Test Circuit for Switching Time

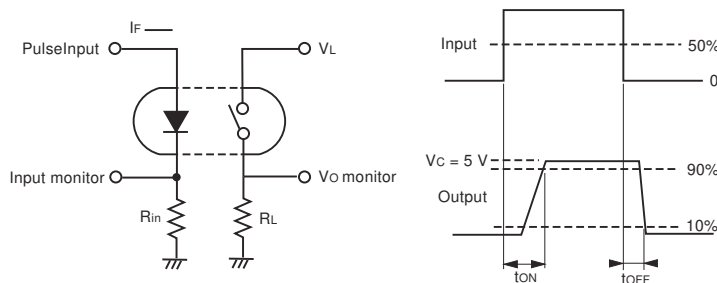

PS7122-1A, PS7122L-1A

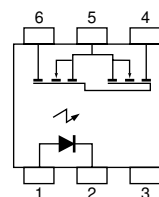

PS7122-2A, PS7122L-2A

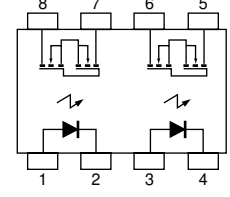

PS7122-1A,-2A, PS7122L-1A,-2A

ABSOLUTE MAXIMUM RATINGS¹ (T_A = 25°C)

SYMBOLS	PARAMETERS	UNITS	RATINGS	
			PS7122-1A PS7122L-1A	PS7122-2A PS7122L-2A
Diode				
I _F	Forward Current (DC)	mA	50	
V _R	Reverse Voltage	V	5.0	
P _D	Power Dissipation	mW/ch	50	
I _{FP}	Peak Forward Current ²	A	1	
MOSFET				
V _L	Break Down Voltage	V	200	
I _L	Continuous Load Current ³			
	Connection A	mA	200	
	Connection B	mA	350	–
	Connection C	mA	500	–
I _{LP}	Pulse Load Current ⁴		400	
	AC/DC Connection	mA		
P _D	Power Dissipation	mW/ch	560	375
COUPLED				
BV	Isolation Voltage ⁵	Vr.m.s.	1500	
P _T	Total Power Dissipation	mW	610	850
T _A	Operating Ambient Temp.	°C	-40 to +80	
T _{STG}	Storage Temperature	°C	-40 to +100	

Notes:

1. Operation in excess of any one of these parameters may result in permanent damage.
2. PW = 100 μs, Duty Cycle = 1 %
3. Conditions: I_F ≥ 2 mA. The following types of load connections are available:

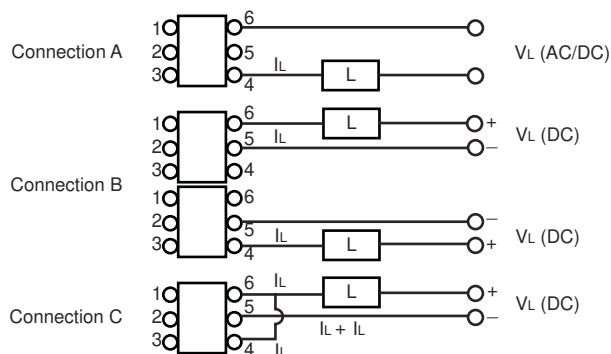

4. PW = 100 ms, 1 shot.
3. AC voltage for 1 minute at T_A = 25 °C, RH = 60 % between input and output.

RECOMMENDED OPERATING CONDITIONS (T_A = 25°C)

PART NUMBER		PS7122-1A,-2A, PS7122L-1A,-2A			
SYMBOLS	PARAMETERS	UNITS	MIN	TYP	MAX
I _F	LED Operating Current	mA	2	10	20
V _F	LED Off Voltage	V	0		0.5

ORDERING INFORMATION

PART NUMBER	PACKAGE	PACKING STYLE
PS7122-1A	6-pin DIP	Magazine case 50 pcs
PS7122L-1A		
PS7122L-1A-E3	8-pin DIP	Embossed tape 1000 pcs/reel
PS7122L-1A-E4		
PS7122-2A	8-pin DIP	Magazine case 50 pcs
PS7122L-2A		
PS7122L-2A-E3	8-pin DIP	Embossed tape 1000 pcs/reel
PS7122L-2A-E4		

OUTLINE DIMENSIONS (Units in mm)

PS7122-1A

PS7122L-1A

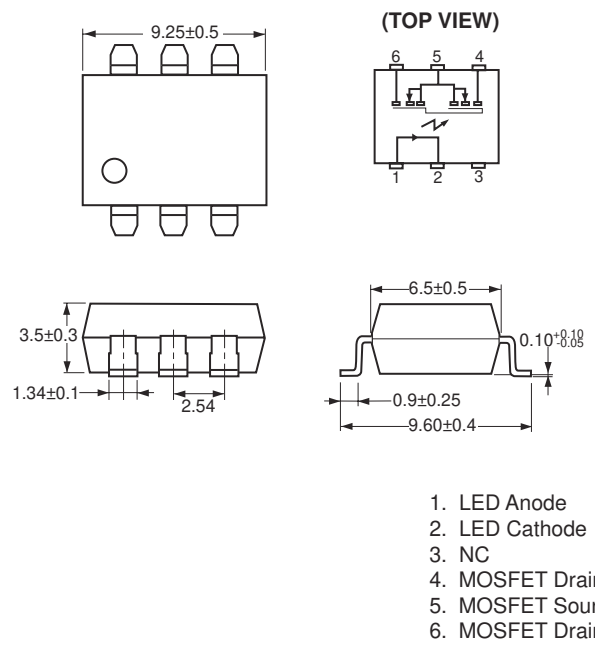
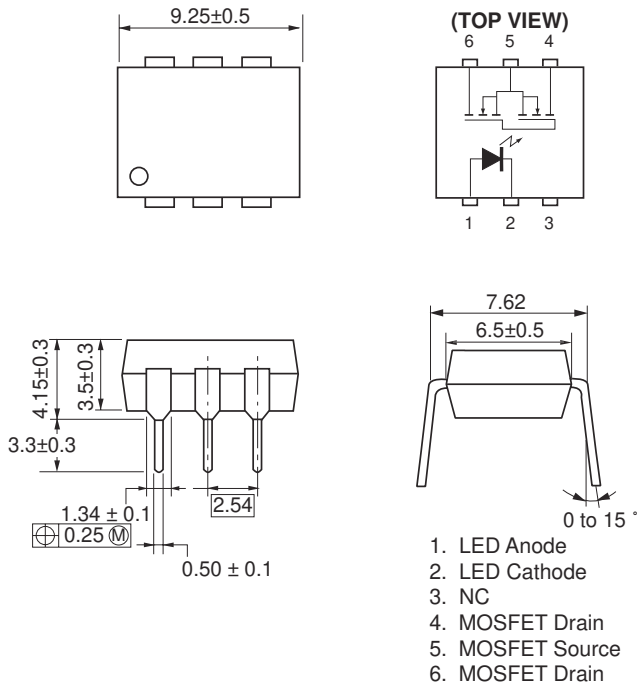

PS7122-2A

PS7122L-2A

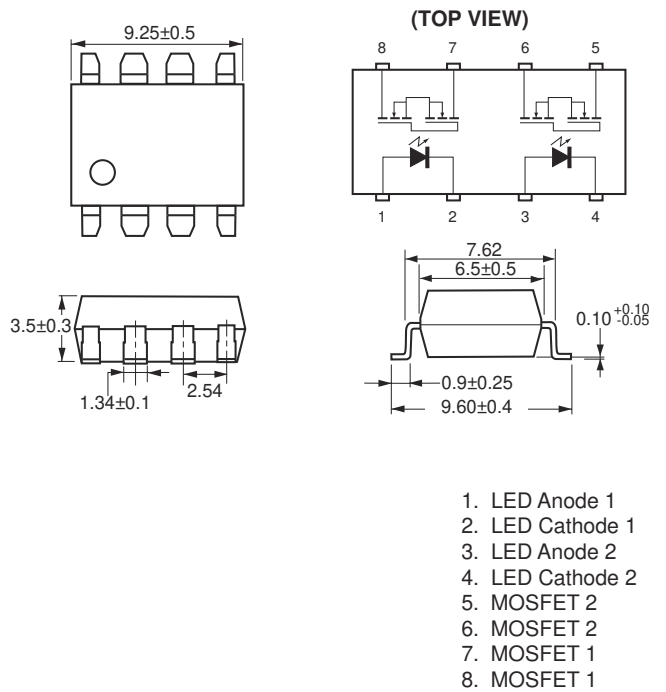
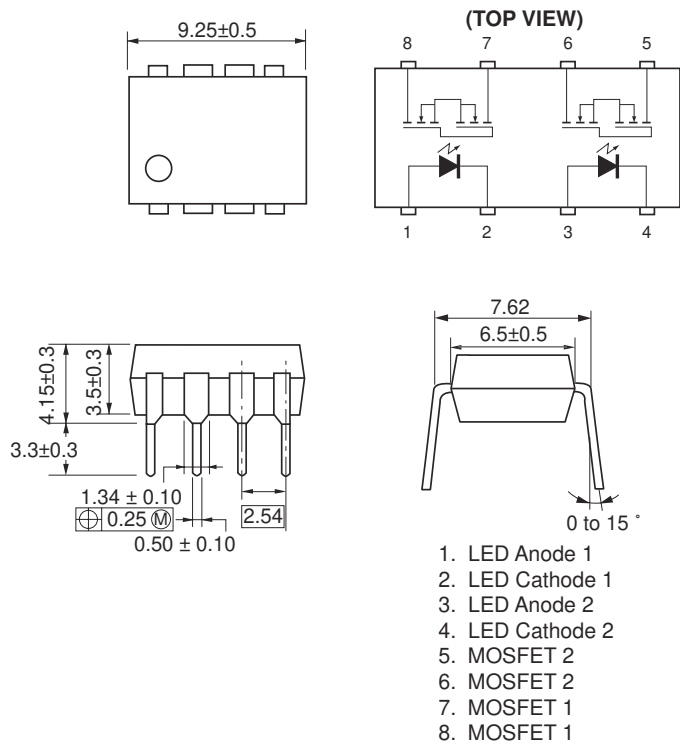

TYPICAL PERFORMANCE CURVES (TA = 25 °C)

MAXIMUM FORWARD CURRENT vs. AMBIENT TEMPERATURE

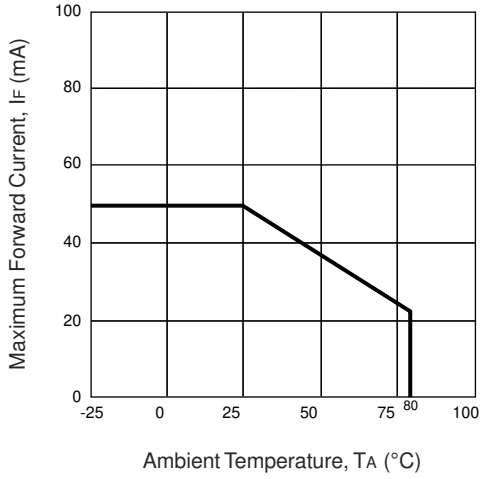

MAXIMUM LOAD CURRENT vs. AMBIENT TEMPERATURE

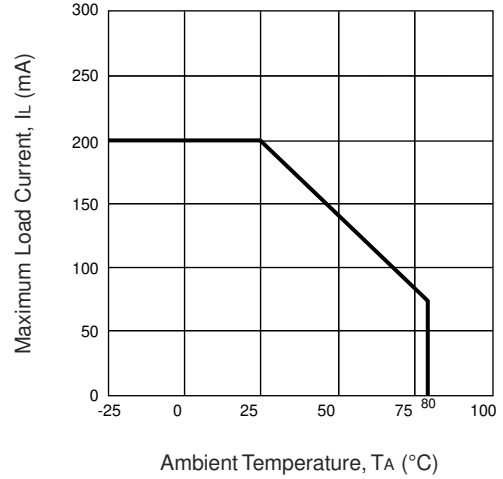

FORWARD VOLTAGE vs. AMBIENT TEMPERATURE

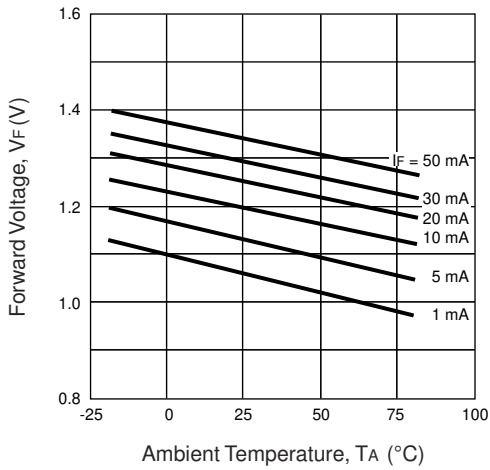

OUTPUT CAPACITANCE vs. APPLIED VOLTAGE

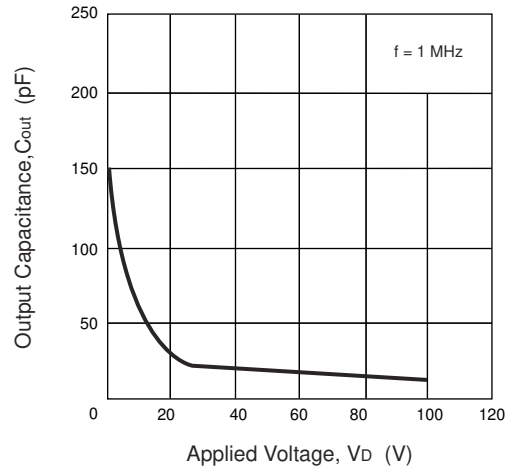

NORMALIZED ON-STATE RESISTANCE vs. AMBIENT TEMPERATURE

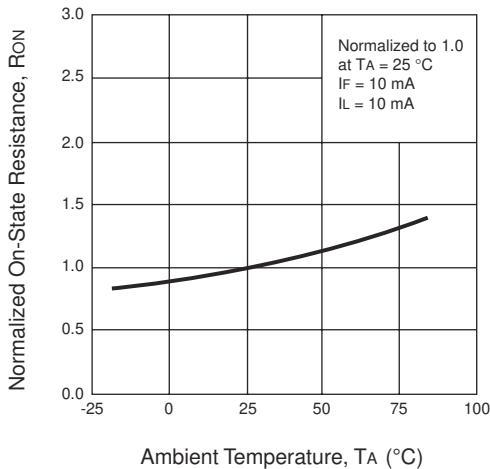

ON-STATE RESISTANCE DISTRIBUTION

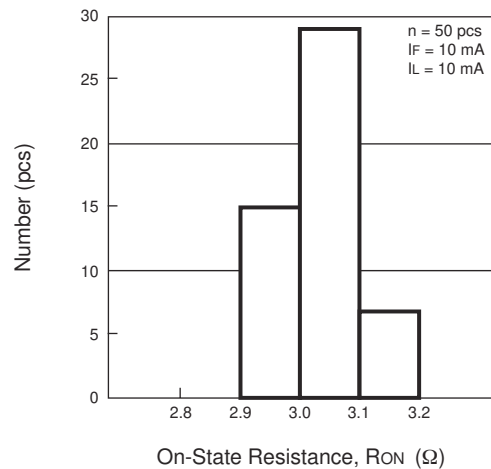

TYPICAL PERFORMANCE CURVES (TA = 25 °C)

OFF-STATE LEAKAGE CURRENT vs. APPLIED VOLTAGE

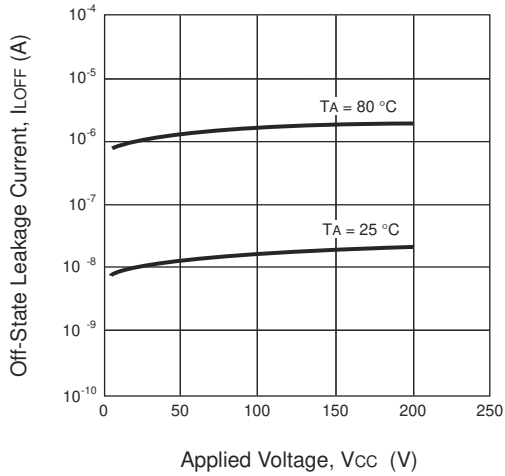

LOAD CURRENT vs. LOAD VOLTAGE

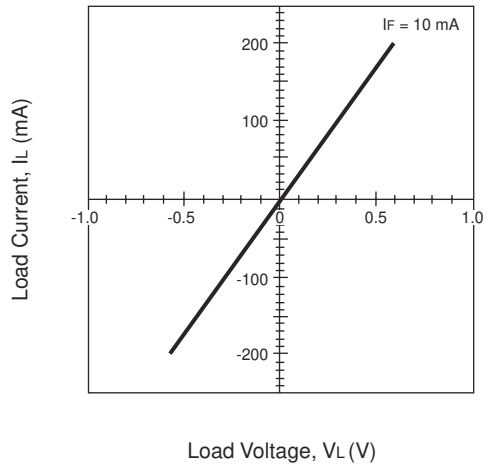

TURN-ON TIME VS. FORWARD CURRENT

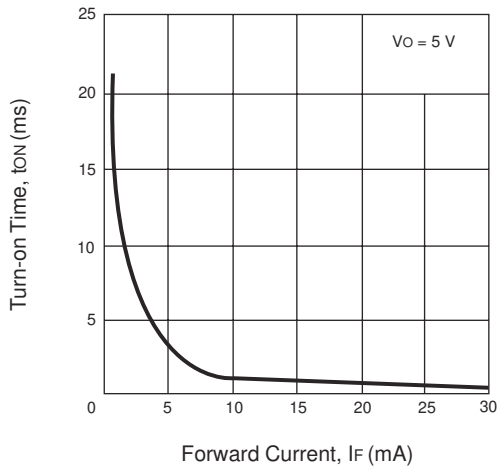

TURN-OFF TIME VS. FORWARD CURRENT

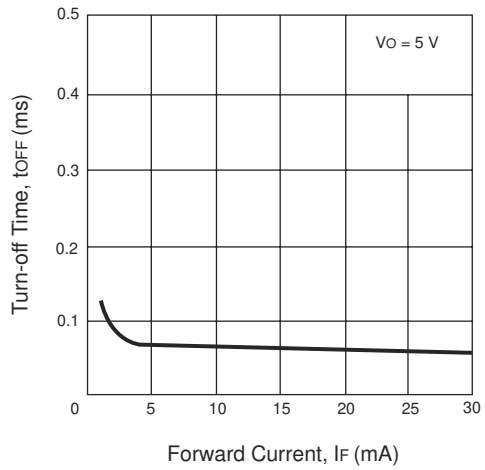

TURN-ON TIME DISTRIBUTION

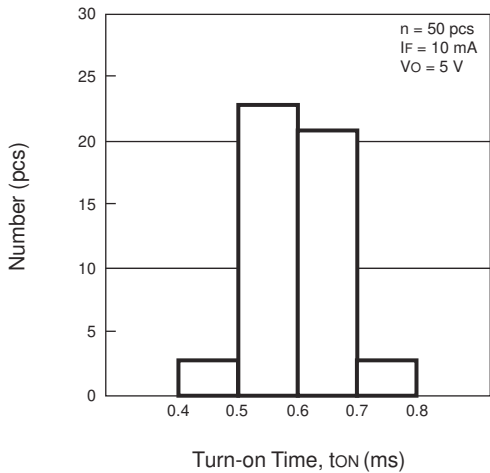

TURN-OFF TIME DISTRIBUTION

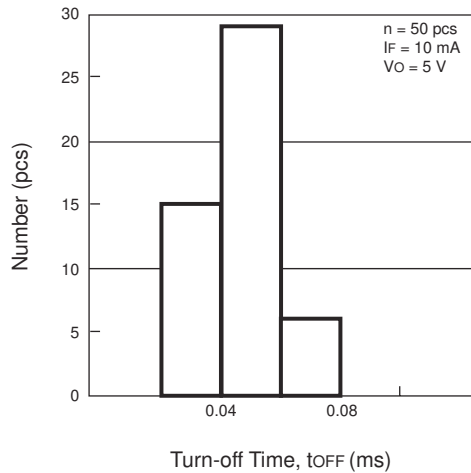

TYPICAL PERFORMANCE CURVES ($T_A = 25\text{ }^\circ\text{C}$)

NORMALIZED TURN-ON TIME vs. AMBIENT TEMPERATURE

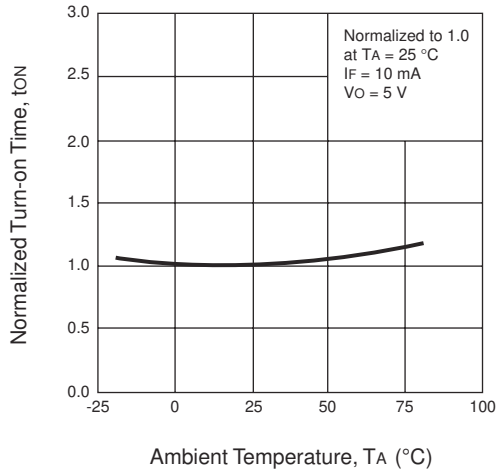

NORMALIZED TURN-OFF TIME vs. AMBIENT TEMPERATURE

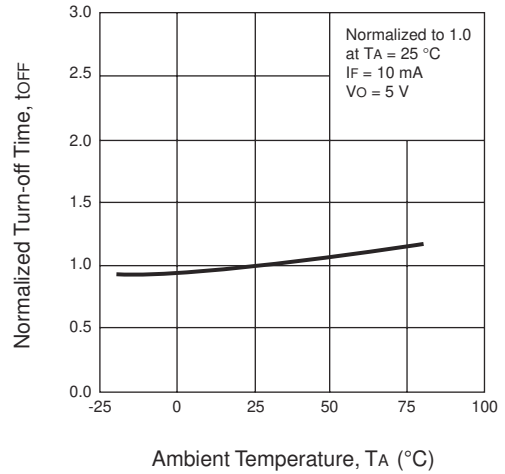

TAPING SPECIFICATIONS (Units in mm)

OUTLINE AND DIMENSIONS (TAPE)

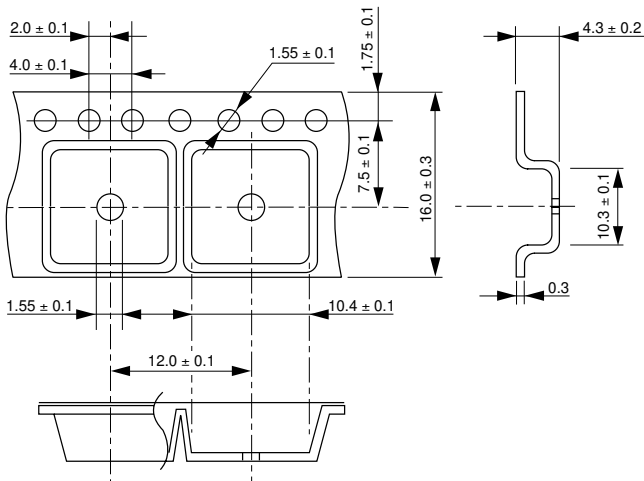

OUTLINE AND DIMENSIONS (REEL)

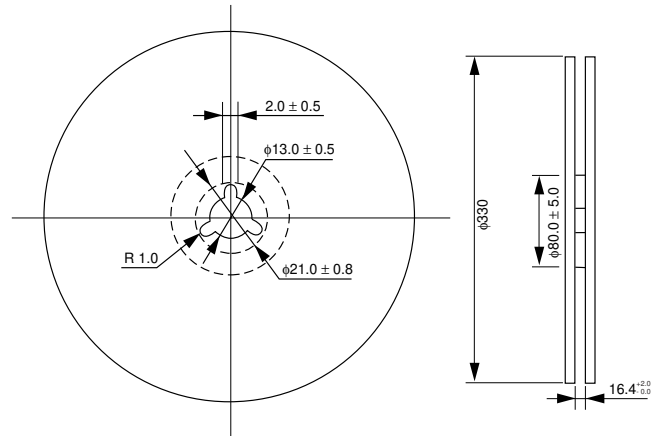

Notes:
 1. Packaging : 1000 pcs/reel

TAPING DIRECTION

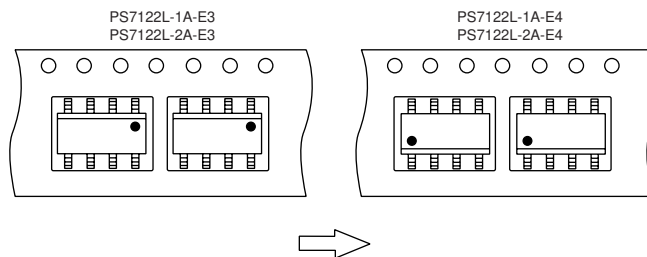

RECOMMENDED SOLDERING CONDITIONS

(1) Infrared reflow soldering

- Peak reflow temperature 235 °C or below (package surface temperature)
- Time of temperature higher than 210 °C 30 seconds or less
- Number of reflows Two
- Flux Rosin flux containing small amount of chlorine
(The flux with a maximum chlorine content of 0.2 Wt % is recommended.)

Recommended Temperature Profile of Infrared Reflow

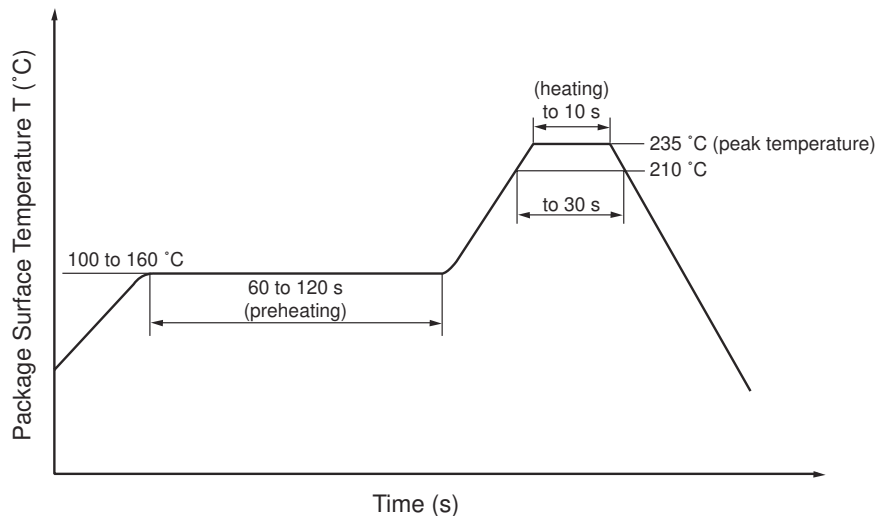

(2) Dip soldering

- Temperature 260 °C or below (molten solder temperature)
- Time 10 seconds or less
- Number of times One
- Flux Rosin flux containing small amount of chlorine
(The flux with a maximum chlorine content of 0.2 Wt % is recommended.)

(3) Cautions

- Fluxes
Avoid removing the residual flux with freon-based cleaning solvent.

EXCLUSIVE NORTH AMERICAN AGENT FOR **NEC** RF, MICROWAVE & OPTOELECTRONIC SEMICONDUCTORS

CEL CALIFORNIA EASTERN LABORATORIES • Headquarters • 4590 Patrick Henry Drive • Santa Clara, CA 95054-1817 • (408) 988-3500 • Telex 34-6393 • FAX (408) 988-0279
24-Hour Fax-On-Demand: 800-390-3232 (U.S. and Canada only) • Internet: <http://WWW.CEL.COM>

DATA SUBJECT TO CHANGE WITHOUT NOTICE

08/15/2001