



Chipsmall Limited consists of a professional team with an average of over 10 year of expertise in the distribution of electronic components. Based in Hongkong, we have already established firm and mutual-benefit business relationships with customers from,Europe,America and south Asia,supplying obsolete and hard-to-find components to meet their specific needs.

With the principle of "Quality Parts,Customers Priority,Honest Operation,and Considerate Service",our business mainly focus on the distribution of electronic components. Line cards we deal with include Microchip,ALPS,ROHM,Xilinx,Pulse,ON,Everlight and Freescale. Main products comprise IC,Modules,Potentiometer,IC Socket,Relay,Connector.Our parts cover such applications as commercial,industrial, and automotives areas.

We are looking forward to setting up business relationship with you and hope to provide you with the best service and solution. Let us make a better world for our industry!



Contact us

Tel: +86-755-8981 8866 Fax: +86-755-8427 6832

Email & Skype: info@chipsmall.com Web: www.chipsmall.com

Address: A1208, Overseas Decoration Building, #122 Zhenhua RD., Futian, Shenzhen, China



6, 8 PIN DIP SLOW SWITCHING TYPE 1-CH, 2-CH OPTICAL COUPLED MOSFET

PS7522-1A
PS7522-2A
PS7522L-1A
PS7522L-2A

FEATURES

- **1 CHANNEL TYPE:**
1a output
OR 2 CHANNEL TYPE:
1a + 1a output
- **LOW LED OPERATING CURRENT:**
 $I_F = 1 \text{ mA}$
- **DESIGNED FOR AC/DC SWITCHING LINE CHANGER**
- **SMALL PACKAGE:**
6, 8 Pin DIP
- **SLOW TURN-ON TIME, SLOW TURN-OFF TIME:**
($t_{on} = 12 \text{ ms MAX}$, $t_{off} = 6.5 \text{ ms MAX}$)
- **LOW OFFSET VOLTAGE**
- **SURFACE MOUNT TYPE LEAD AVAILABLE:**
PS7522L-1A, 2A

DESCRIPTION

PS7522-1A,-2A and PS7522L-1A,-2A are solid state relays containing GaAs LEDs on the light emitting side (input side) and MOSFETs on the output side.

They are suitable for analog signal control because of their slow switching speed at turn-on or turn-off.

APPLICATIONS

- EXCHANGE EQUIPMENT
- MEASUREMENT EQUIPMENT
- FA/OA EQUIPMENT

ELECTRICAL CHARACTERISTICS ($T_A = 25^\circ\text{C}$)

PART NUMBER			PS7522-1A, 2A, PS7522L-1A, 2A			
SYMBOLS		PARAMETERS	UNITS	MIN	TYP	MAX
Diode	V_F	Forward Voltage, $I_F = 1.4 \text{ mA}$	V		1.1	1.4
	I_R	Reverse Current, $V_R = 5 \text{ V}$	μA			5.0
MOSFET	I_{Loff}	Off-State Leakage Current, $V_D = 200 \text{ V}$	μA		0.03	1.0
	C_{OUT}	Output Capacitance, $V_D = 0 \text{ V}$, $f = 1 \text{ MHz}$	pF/ch		165	
Coupled	I_{Foff}	LED On-state Current, $I_L = 200 \text{ mA}$	mA			1.0
	R_{on1}	On-State Resistance, $I_F = 1.4 \text{ mA}$, $I_L = 10 \text{ mA}$	Ω		3.0	5.0
	t_{on}	Turn-On Time ¹ , $I_F = 1.4 \text{ mA}$, $V_O = 60 \text{ V}$, $PW \geq 50 \text{ ms}$	ms		8.5	12
	t_{off}	Turn-Off Time ¹ , $I_F = 1.4 \text{ mA}$, $V_O = 60 \text{ V}$, $PW \geq 50 \text{ ms}$	ms		3.0	6.5
	t_r	Rise time, $I_F = 1.4 \text{ mA}$, $V_O = 60 \text{ V}$, $PW \geq 50 \text{ ms}$	ms	0.80	2.78	
	t_f	Fall time, $I_F = 1.4 \text{ mA}$, $V_O = 60 \text{ V}$, $PW \geq 50 \text{ ms}$	ms	0.4	0.8	
	R_{I-O}	Isolation Resistance, $V_{in-out} = 1.0 \text{ kVDC}$	Ω	10^9		
C_{I-O}	Isolation Capacitance, $V = 0 \text{ V}$, $f = 1 \text{ MHz}$	pF/ch		1.1		

Note:

1. Test circuit for Switching Time

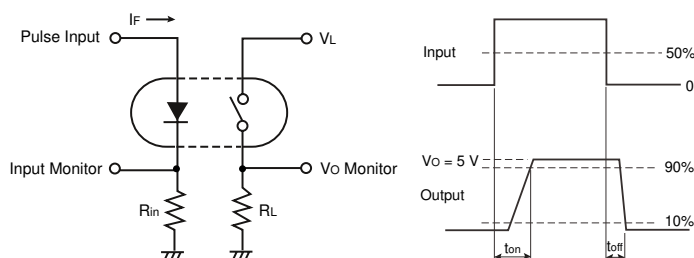

PS7522-1A, PS7522L-1A

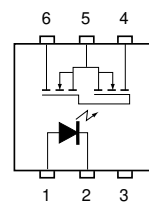

PS7522-2A, PS7522L-2A

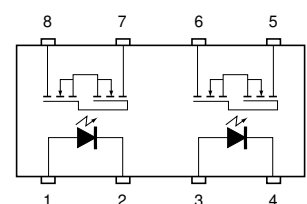

PS7522-1A, -2A, PS7522L-1A, -2A

ABSOLUTE MAXIMUM RATINGS¹ (T_A = 25°C)

SYMBOLS	PARAMETERS	UNITS	RATINGS	
			PS7522-1A PS7522L-1A	PS7522-2A PS7522L-2A
Diode				
V _R	Reverse Voltage	V	5	
I _F	Forward Current (DC)	mA	50	
P _D	Power Dissipation	mW/ch	50	
I _{FP}	Peak Forward Current ²	A	1	
MOSFET				
V _L	Break Down Voltage	V	200	
I _L	Continuous Load Current ³	Connection A	200	
		Connection B	350	–
		Connection C	400	–
I _{LP}	Pulse Load Current ⁴ (AC/DC Connection)	mA	400	
P _D	Power Dissipation	mW/ch	560	375
Coupled				
BV	Isolation Voltage ⁵	Vr.m.s.	1500	
P _T	Total Power Dissipation	mW	610	850
T _A	Operating Ambient Temp.	°C	-40 to +80	
T _{STG}	Storage Temperature	°C	-40 to +100	

Notes:

- Operation in excess of any one of these parameters may result in permanent damage.
- PW = 100 μs, Duty Cycle = 1%.
- Conditions: I_F ≥ 2 mA. The following types of load connections are available.

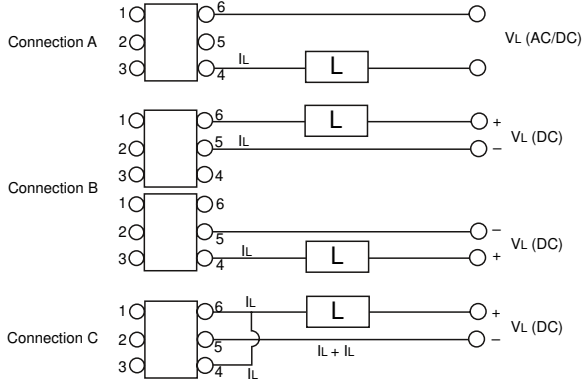

- PW = 100 ms, 1 shot.
- AC voltage for 1 minute at T_A = 25 °C, RH = 60 % between input and output.

RECOMMENDED OPERATING CONDITIONS (T_A = 25 °C)

SYMBOL	PARAMETER	UNITS	MIN	TYP	MAX
I _F	LED Operating Current	mA	1	10	20
V _F	LED Off Voltage	V	0		0.5

ORDERING INFORMATION

PART NUMBER	PACKAGE	PACKING STYLE
PS7522-1A	6 Pin DIP	Magazine case, 50 pcs
PS7522L-1A		Embossed Tape, 1000 pcs/reel
PS7522L-1A-E3		
PS7522L-1A-E4		
PS7522-2A	8 Pin DIP	Magazine case, 50 pcs
PS7522L-2A		Embossed Tape, 1000 pcs/reel
PS7522L-2A-E3		
PS7522L-2A-E4		

TYPICAL PERFORMANCE CURVES ($T_A = 25^\circ\text{C}$)

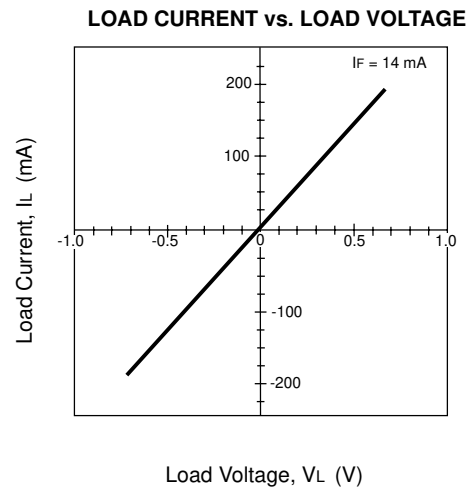
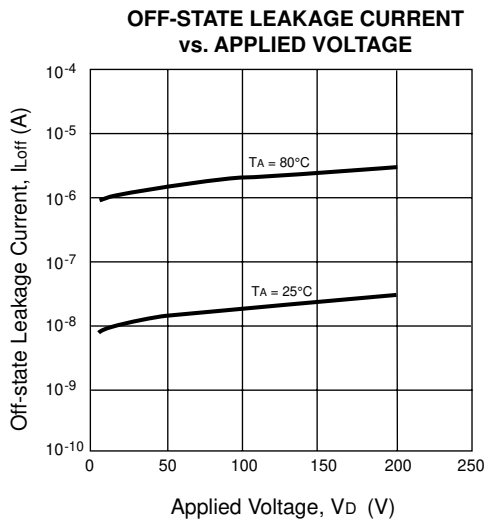
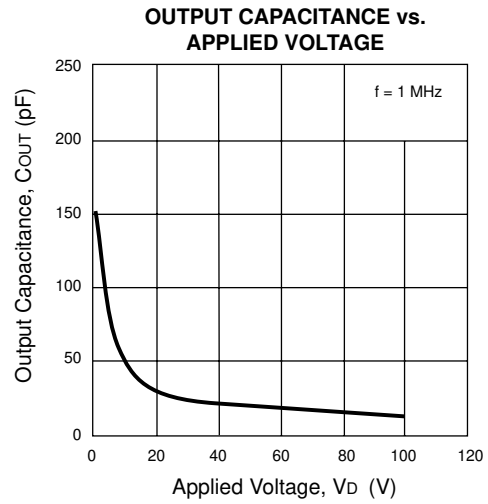
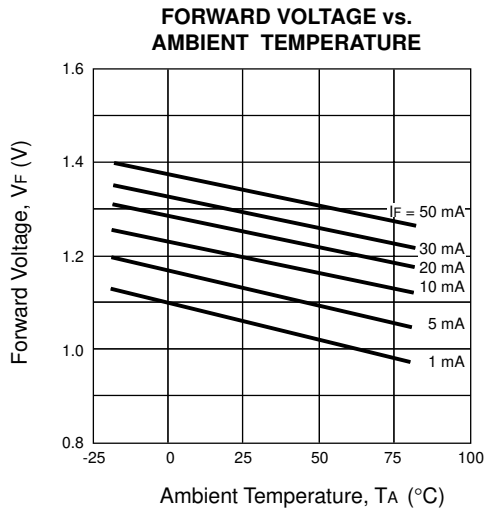
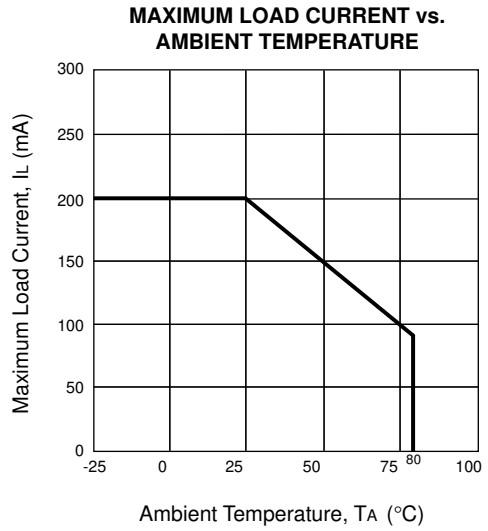
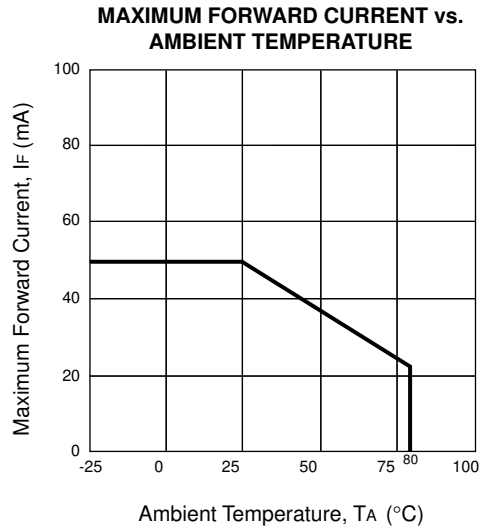

TYPICAL PERFORMANCE CURVES (TA = 25 °C)

NORMALIZED ON-STATE RESISTANCE vs. AMBIENT TEMPERATURE

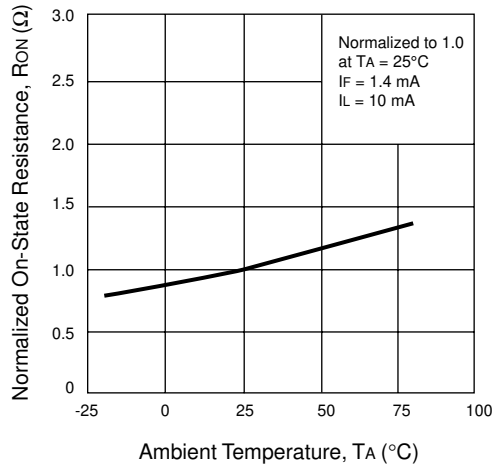

ON-STATE RESISTANCE DISTRIBUTION

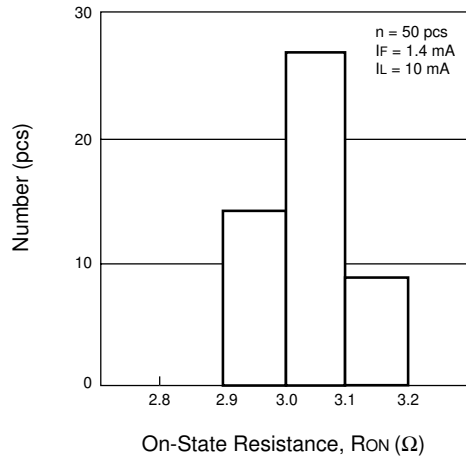

TURN-ON TIME vs. FORWARD CURRENT

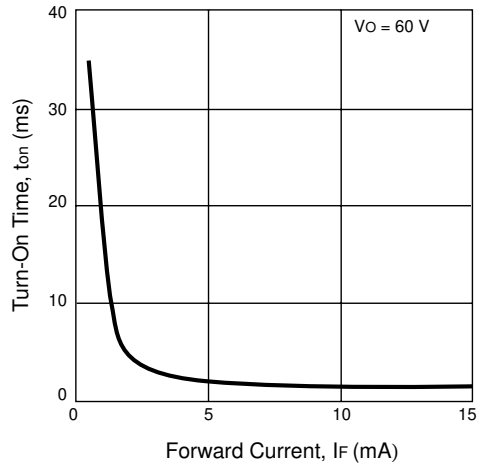

TURN-OFF TIME vs. FORWARD CURRENT

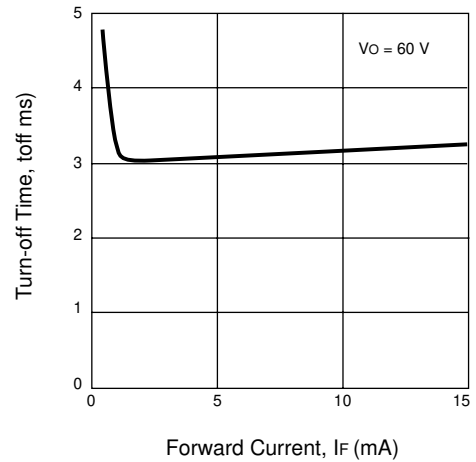

TURN-ON TIME DISTRIBUTION

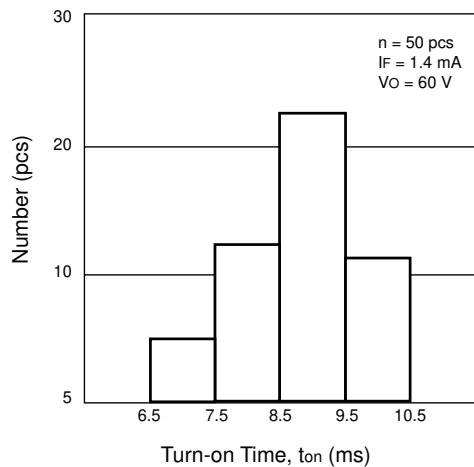

TURN-OFF TIME DISTRIBUTION

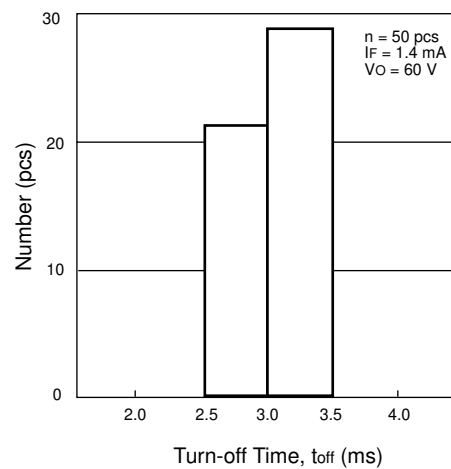

TYPICAL PERFORMANCE CURVES (TA = 25 °C)

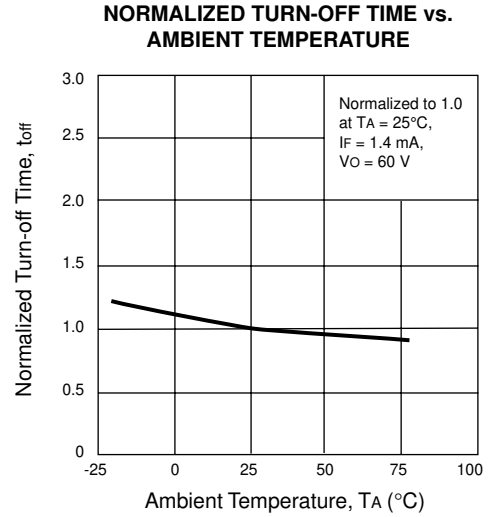
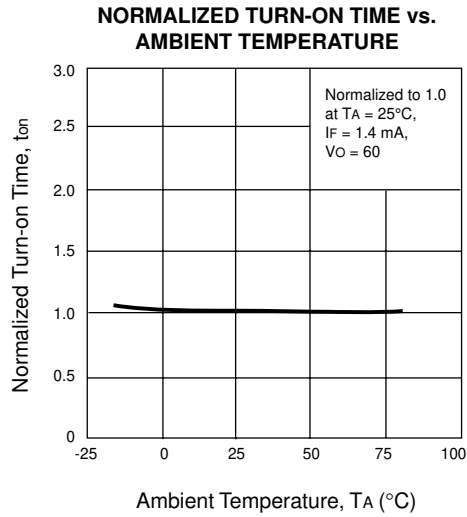

OUTLINE DIMENSIONS (Units in mm)

PS7522-1A

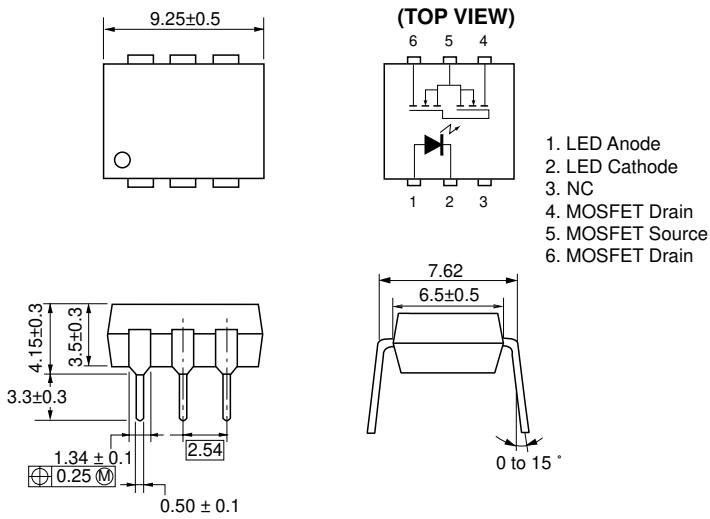

PS7522L-1A

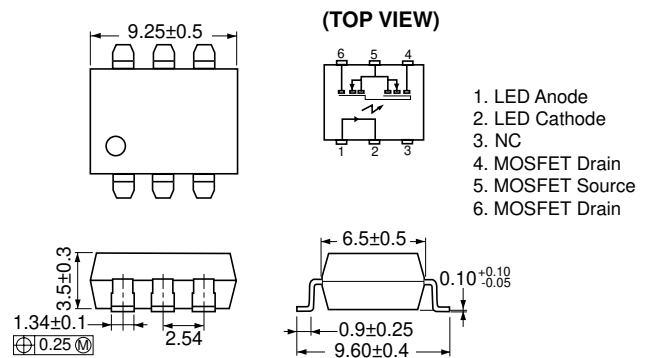

PS7522-2A

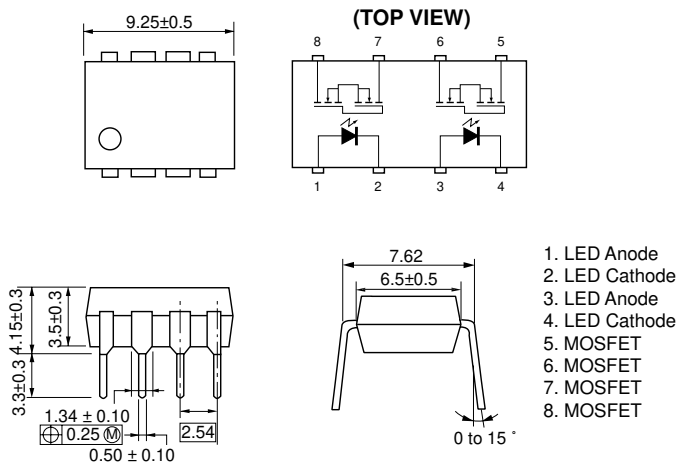

PS7522L-2A

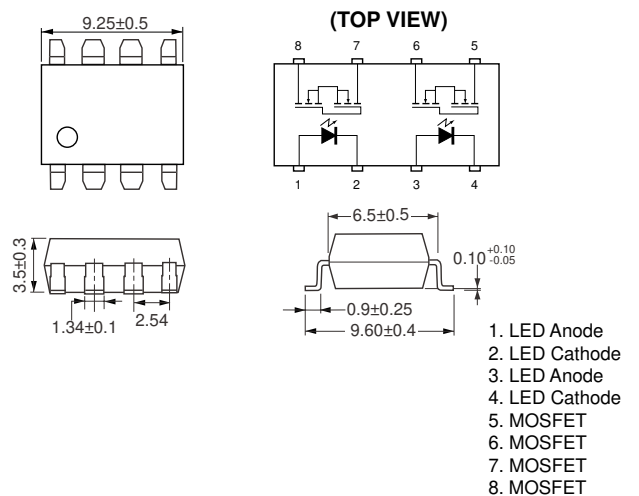

RECOMMENDED SOLDERING CONDITIONS

(1) Infrared reflow soldering

- Peak reflow temperature 235 °C or below (package surface temperature)
- Time of temperature higher than 210 °C 30 seconds or less
- Number of reflows Two
- Flux Rosin flux containing small amount of chlorine
(The flux with a maximum chlorine content of 0.2 Wt % is recommended.)

Recommended Temperature Profile of Infrared Reflow

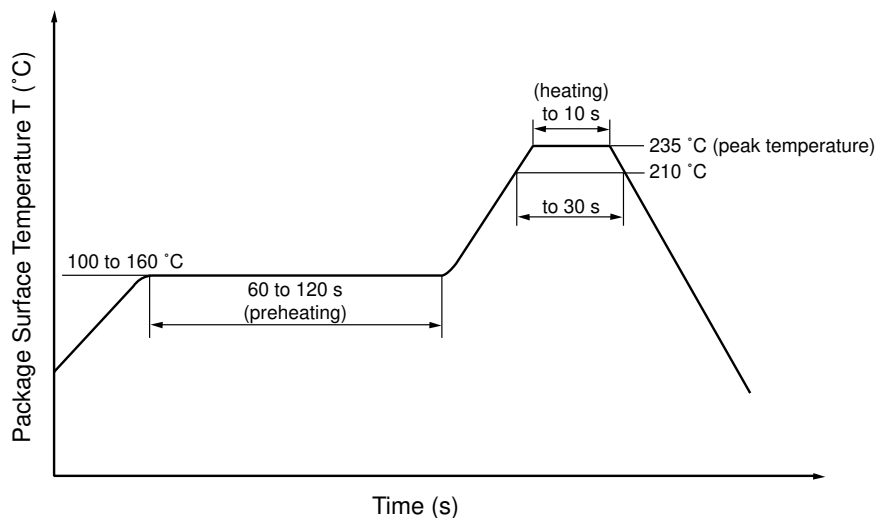

(2) Dip soldering

- Temperature 260 °C or below (molten solder temperature)
- Time 10 seconds or less
- Number of times One
- Flux Rosin flux containing small amount of chlorine
(The flux with a maximum chlorine content of 0.2 Wt % is recommended.)

(3) Cautions

- Fluxes
Avoid removing the residual flux with freon-based cleaning solvent.