



Chipsmall Limited consists of a professional team with an average of over 10 year of expertise in the distribution of electronic components. Based in Hongkong, we have already established firm and mutual-benefit business relationships with customers from,Europe,America and south Asia,supplying obsolete and hard-to-find components to meet their specific needs.

With the principle of “Quality Parts,Customers Priority,Honest Operation,and Considerate Service”,our business mainly focus on the distribution of electronic components. Line cards we deal with include Microchip,ALPS,ROHM,Xilinx,Pulse,ON,Everlight and Freescale. Main products comprise IC,Modules,Potentiometer,IC Socket,Relay,Connector.Our parts cover such applications as commercial,industrial, and automotives areas.

We are looking forward to setting up business relationship with you and hope to provide you with the best service and solution. Let us make a better world for our industry!



Contact us

Tel: +86-755-8981 8866 Fax: +86-755-8427 6832

Email & Skype: info@chipsmall.com Web: www.chipsmall.com

Address: A1208, Overseas Decoration Building, #122 Zhenhua RD., Futian, Shenzhen, China





PHOTOCOUPLER PS9401-2

0.6 A OUTPUT CURRENT, HIGH CMR, 16-PIN SSOP (SO-16) 2 CHANNEL IGBT GATE DRIVE PHOTOCOUPLER

-NEPOC Series-

DESCRIPTION

The PS9401-2 is optical coupled isolators containing a GaAlAs LED on the input side and a photo diode and a photo diode, a signal processing circuit and a power output transistor on the output side on one chip.

The PS9401-2 is designed specifically for high common mode transient immunity (CMR) and high switching speed. It is suitable for driving IGBTs and MOS FETs.

The PS9401-2 integrated dual channel into a 16-pin plastic SSOP (Shrink Small Outline Package). And the PS9401-2 is suitable for high density applications.

FEATURES

- Integrated dual channel into a 16-pin SSOP
- Peak output current (0.6 A MAX., 0.4 A MIN.)
- High speed switching ($t_{PLH}/t_{PHL} = 0.7 \mu s$ MAX.)
- High common mode transient immunity ($CM_H, CM_L = \pm 15 kV/\mu s$ MIN.)
- Pb-Free product

APPLICATIONS

- IGBT, Power MOS FET Gate Driver
- Industrial inverter
- IH (Induction Heating)
- PDP

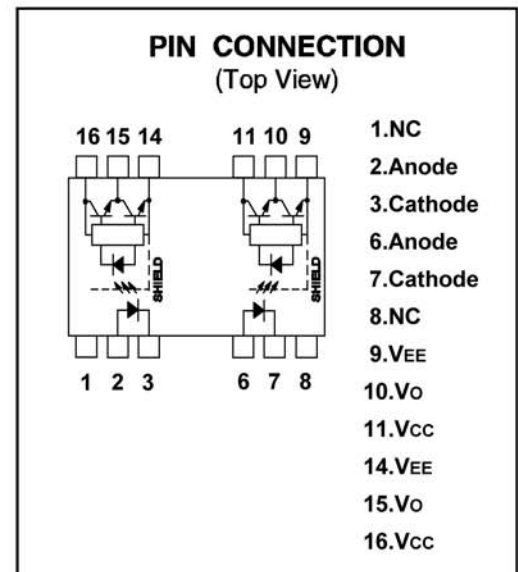

The information in this document is subject to change without notice. Before using this document, please confirm that this is the latest version.

PACKAGE DIMENSIONS (UNIT: mm)

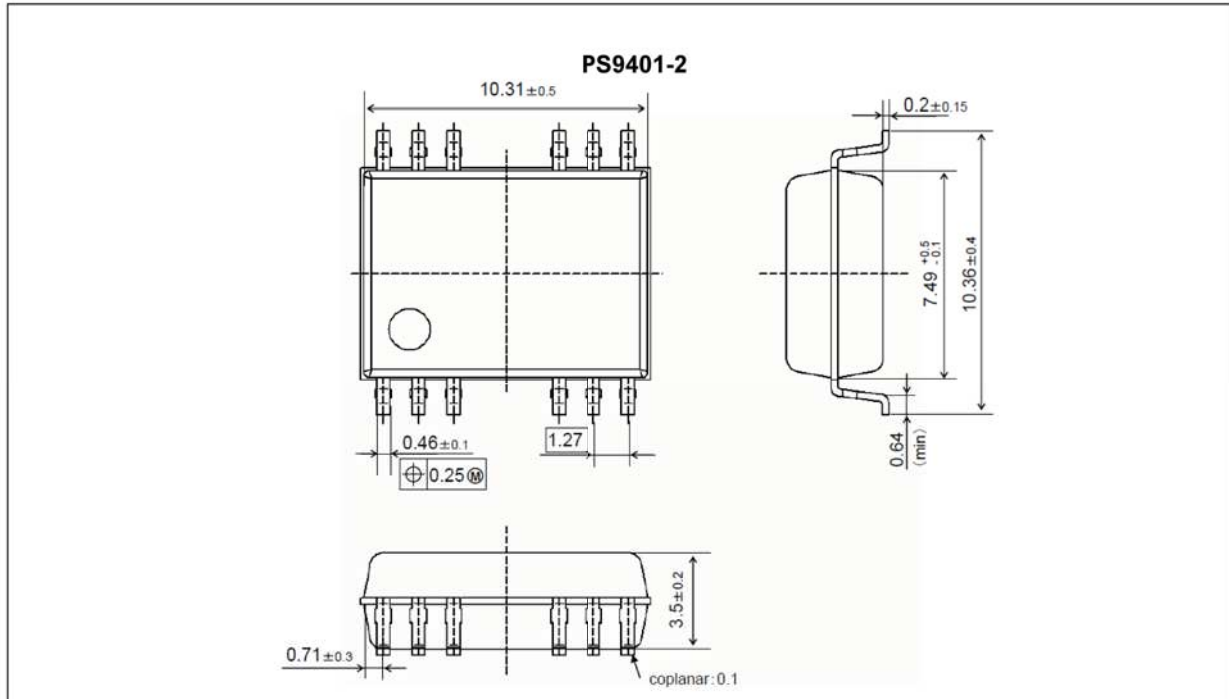

MARKING EXAMPLE

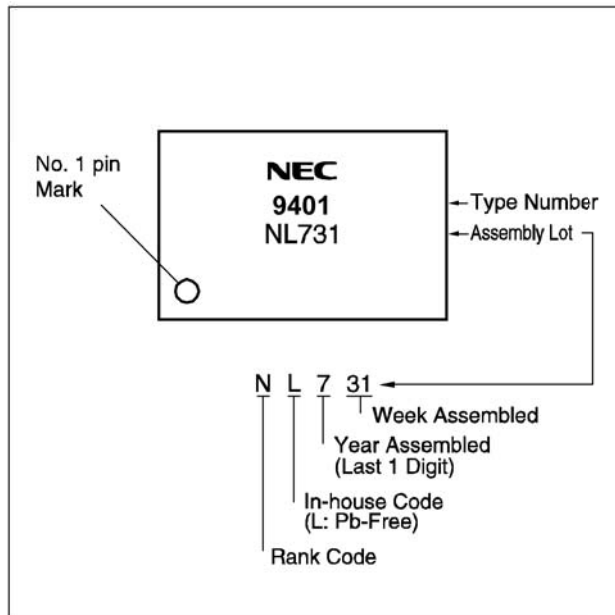

PHOTOCOUPLER CONSTRUCTION

Parameter	PS9401-2
Air Distance (MIN.)	8 mm
Outer Creepage Distance (MIN.)	8 mm
Isolation Distance (MIN.)	0.4 mm

ABSOLUTE MAXIMUM RATINGS (T_A = 25°C, unless otherwise specified)

Parameter		Symbol	Ratings	Unit
Diode	Forward Current *1	I _F	25	mA
	Peak Transient Forward Current (Pulse Width < 1 μs)	I _{F (TRAN)}	1.0	A
	Reverse Voltage	V _R	5	V
Detector	High Level Peak Output Current *1	I _{OH (PEAK)}	0.6	A
	Low Level Peak Output Current *1	I _{OL (PEAK)}	0.6	A
	Supply Voltage	(V _{CC} - V _{EE})	0 to 35	V
	Output Voltage	V _O	0 to V _{CC}	V
	Power Dissipation	P _C	250	mW
Isolation Voltage *2		BV	5 000	Vr.m.s.
Insulation Viltage (Output - Output) *3		V _{O-O}	1 500	Vr.m.s.
Total Power Dissipation		P _T	360	mW
Operating Frequency *4		f	25	kHz
Operating Ambient Temperature		T _A	-40 to +100	°C
Storage Temperature		T _{stg}	-55 to +125	°C

*1 Maximum pulse width = 10 μs, Maximum duty cycle = 0.2%

*2 AC voltage for 1 minute at T_A = 25°C, RH = 60% between input and output.

Pins 1-8 shorted together, 9-16 shorted together.

*3 V_{O-O} is measured with Pins 9-11 shorted together, 14-16 shorted together.

*4 I_{OH (PEAK)} ≤ 0.4 A (≤ 2.0 μs), I_{OL (PEAK)} ≤ 0.4 A (≤ 2.0 μs)

RECOMMENDED OPERATING CONDITIONS

Parameter	Symbol	MIN.	TYP.	MAX.	Unit
Supply Voltage	(V _{CC} - V _{EE})	10		30	V
Forward Current (ON)	I _{F (ON)}	8		12	mA
Forward Voltage (OFF)	V _{F (OFF)}	-2		0.8	V
Operating Ambient Temperature	T _A	-40		100	°C

ELECTRICAL CHARACTERISTICS (T_A = -40 to +100°C, V_{CC} = 10 to 30 V, V_{EE} = GND, I_{F(ON)} = 8 to 12 mA, V_{F(OFF)} = -2 to 0.8 V, unless otherwise specified)

Parameter		Symbol	Conditions	MIN.	TYP.* ¹	MAX.	Unit
Diode	Forward Voltage	V _F	I _F = 10 mA, T _A = 25°C	1.2	1.56	1.9	V
	Reverse Current	I _R	V _R = 3 V, T _A = 25°C			10	μA
Detector	High Level Output Current	I _{OH}	V _O = (V _{CC} - 4 V) ^{*2}	0.2			A
			V _O = (V _{CC} - 10 V) ^{*3}	0.4	0.5		
	Low Level Output Current	I _{OL}	V _O = (V _{EE} + 2.5 V) ^{*2}	0.2	0.4		A
			V _O = (V _{EE} + 10 V) ^{*3}	0.4	0.5		
	High Level Output Voltage	V _{OH}	I _O = -100 mA ^{*4}	V _{CC} - 4.0	V _{CC} - 1.8		V
	Low Level Output Voltage	V _{OL}	I _O = 100 mA		0.4	1.0	V
	High Level Supply Current	I _{CCH}	I _O = 0 mA ^{*5}		0.7	3.0	mA
	Low Level Supply Current	I _{CCL}	I _O = 0 mA ^{*5}		1.2	3.0	mA
Coupled	Threshold Input Current (L → H)	I _{FLH}	I _O = 0 mA, V _O > 5 V			5.0	mA
	Threshold Input Voltage (H → L)	V _{FHL}	I _O = 0 mA, V _O < 5 V	0.8			V
	Isolation Capaitance	C _{I-O}	f = 1 MHz, V _F = 0 V, T _A = 25°C		60		pF

*1 Typical values at T_A = 25°C, V_{CC} - V_{EE} = 30V.

*2 Maximum pulse width = 50 μs, Maximum duty cycle = 0.5%.

*3 Maximum pulse width = 10 μs, Maximum duty cycle = 0.2%

*4 V_{OH} is measured with the DC load current in this testing.

*5 The I_{CCH} and I_{CCL} increases when operating frequency and Q_β of the driven IGBT increases.

**SWITCHING CHARACTERISTICS ($T_A = -40$ to $+100^\circ\text{C}$, $V_{CC} = 10$ to 30 V, $V_{EE} = \text{GND}$,
 $I_F(\text{ON}) = 8$ to 12 mA, $V_F(\text{OFF}) = -2$ to 0.8 V, unless otherwise specified)**

Parameter	Symbol	Conditions	MIN.	TYP.**1	MAX.	Unit
Propagation Delay Time (L → H)	t_{PLH}	$I_F = 10$ mA, $V_{CC} = 30$ V	0.1	0.2	0.7	μs
Propagation Delay Time (H → L)	t_{PHL}	$R_G = 47 \Omega$, $C_G = 3$ nF, $f = 10$ kHz,	0.1	0.2	0.7	μs
Pulse Width Distortion (PWD)	$ t_{PHL} - t_{PLH} $	Duty Cycle = 50%**2			0.5	μs
Propagation Delay Time (Difference Between Any Two Products)	$t_{PHL} - t_{PLH}$		-0.5		0.5	μs
Rise Time	t_r			50		ns
Fall Time	t_f			50		ns
Common Mode Transient Immunity at High Level Output*3	CM_H	$T_A = 25^\circ\text{C}$, $I_F = 10$ mA, $V_{CC} = 30$ V, $V_{O(\text{MIN})} = 26$ V, $V_{CM} = 1.5$ k V	15			kV/ μs
Common Mode Transient Immunity at Low Level Output*3	CM_L	$T_A = 25^\circ\text{C}$, $I_F = 0$ mA, $V_{CC} = 30$ V, $V_{O(\text{MAX})} = 1$ V, $V_{CM} = 1.5$ k V	15			kV/ μs

*1 Typical values at $T_A = 25^\circ\text{C}$, $V_{CC} - V_{EE} = 30$ V.

*2 This load condition is equivalent to the IGBT load at 1 200 V/25 A.

*3 Connect pin 1 and pin 8 to the LED common.

NOTES ON HANDLING

Cautions regarding noise

Be aware that when voltage is applied suddenly between the photocoupler's input and output at startup, the output transistor may enter the on state, even if the voltage is within the absolute maximum ratings.

USAGE CAUTIONS

1. This product is weak for static electricity by designed with high-speed integrated circuit so protect against static electricity when handling.
2. Board designing
 - (1) By-pass capacitor of more than 0.1 μF is used between V_{CC} and GND near device. Also, ensure that the distance between the leads of the photocoupler and capacitor is no more than 10 mm.
 - (2) In order to avoid malfunctions and characteristics degradation, IGBT collector or emitter traces should not be closed to the LED input.
3. Make sure the rise/fall time of the forward current is 0.5 μs or less.
4. In order to avoid malfunctions, make sure the rise/fall slope of the supply voltage is 3 V/ μs or less.
5. Avoid storage at a high temperature and high humidity.

- **The information in this document is current as of October, 2007. The information is subject to change without notice. For actual design-in, refer to the latest publications of NEC Electronics data sheets or data books, etc., for the most up-to-date specifications of NEC Electronics products. Not all products and/or types are available in every country. Please check with an NEC Electronics sales representative for availability and additional information.**
- No part of this document may be copied or reproduced in any form or by any means without the prior written consent of NEC Electronics. NEC Electronics assumes no responsibility for any errors that may appear in this document.
- NEC Electronics does not assume any liability for infringement of patents, copyrights or other intellectual property rights of third parties by or arising from the use of NEC Electronics products listed in this document or any other liability arising from the use of such products. No license, express, implied or otherwise, is granted under any patents, copyrights or other intellectual property rights of NEC Electronics or others.
- Descriptions of circuits, software and other related information in this document are provided for illustrative purposes in semiconductor product operation and application examples. The incorporation of these circuits, software and information in the design of a customer's equipment shall be done under the full responsibility of the customer. NEC Electronics assumes no responsibility for any losses incurred by customers or third parties arising from the use of these circuits, software and information.
- While NEC Electronics endeavors to enhance the quality, reliability and safety of NEC Electronics products, customers agree and acknowledge that the possibility of defects thereof cannot be eliminated entirely. To minimize risks of damage to property or injury (including death) to persons arising from defects in NEC Electronics products, customers must incorporate sufficient safety measures in their design, such as redundancy, fire-containment and anti-failure features.
- NEC Electronics products are classified into the following three quality grades: "Standard", "Special" and "Specific".

The "Specific" quality grade applies only to NEC Electronics products developed based on a customer-designated "quality assurance program" for a specific application. The recommended applications of an NEC Electronics product depend on its quality grade, as indicated below. Customers must check the quality grade of each NEC Electronics product before using it in a particular application.

"Standard": Computers, office equipment, communications equipment, test and measurement equipment, audio and visual equipment, home electronic appliances, machine tools, personal electronic equipment and industrial robots.

"Special": Transportation equipment (automobiles, trains, ships, etc.), traffic control systems, anti-disaster systems, anti-crime systems, safety equipment and medical equipment (not specifically designed for life support).

"Specific": Aircraft, aerospace equipment, submersible repeaters, nuclear reactor control systems, life support systems and medical equipment for life support, etc.

The quality grade of NEC Electronics products is "Standard" unless otherwise expressly specified in NEC Electronics data sheets or data books, etc. If customers wish to use NEC Electronics products in applications not intended by NEC Electronics, they must contact an NEC Electronics sales representative in advance to determine NEC Electronics' willingness to support a given application.

(Note)

- (1) "NEC Electronics" as used in this statement means NEC Electronics Corporation and also includes its majority-owned subsidiaries.
- (2) "NEC Electronics products" means any product developed or manufactured by or for NEC Electronics (as defined above).

Caution	GaAs Products	<p>This product uses gallium arsenide (GaAs). GaAs vapor and powder are hazardous to human health if inhaled or ingested, so please observe the following points.</p> <ul style="list-style-type: none">• Follow related laws and ordinances when disposing of the product. If there are no applicable laws and/or ordinances, dispose of the product as recommended below.<ol style="list-style-type: none">1. Commission a disposal company able to (with a license to) collect, transport and dispose of materials that contain arsenic and other such industrial waste materials.2. Exclude the product from general industrial waste and household garbage, and ensure that the product is controlled (as industrial waste subject to special control) up until final disposal.• Do not burn, destroy, cut, crush, or chemically dissolve the product.• Do not lick the product or in any way allow it to enter the mouth.
----------------	---------------	--

Subject: Compliance with EU Directives

CEL certifies, to its knowledge, that semiconductor and laser products detailed below are compliant with the requirements of European Union (EU) Directive 2002/95/EC Restriction on Use of Hazardous Substances in electrical and electronic equipment (RoHS) and the requirements of EU Directive 2003/11/EC Restriction on Penta and Octa BDE.

CEL Pb-free products have the same base part number with a suffix added. The suffix –A indicates that the device is Pb-free. The –AZ suffix is used to designate devices containing Pb which are exempted from the requirement of RoHS directive (*). In all cases the devices have Pb-free terminals. All devices with these suffixes meet the requirements of the RoHS directive.

This status is based on CEL’s understanding of the EU Directives and knowledge of the materials that go into its products as of the date of disclosure of this information.

Restricted Substance per RoHS	Concentration Limit per RoHS (values are not yet fixed)	Concentration contained in CEL devices	
		-A	-AZ
Lead (Pb)	< 1000 PPM	Not Detected	(*)
Mercury	< 1000 PPM	Not Detected	
Cadmium	< 100 PPM	Not Detected	
Hexavalent Chromium	< 1000 PPM	Not Detected	
PBB	< 1000 PPM	Not Detected	
PBDE	< 1000 PPM	Not Detected	

If you should have any additional questions regarding our devices and compliance to environmental standards, please do not hesitate to contact your local representative.

Important Information and Disclaimer: Information provided by CEL on its website or in other communications concerning the substance content of its products represents knowledge and belief as of the date that it is provided. CEL bases its knowledge and belief on information provided by third parties and makes no representation or warranty as to the accuracy of such information. Efforts are underway to better integrate information from third parties. CEL has taken and continues to take reasonable steps to provide representative and accurate information but may not have conducted destructive testing or chemical analysis on incoming materials and chemicals. CEL and CEL suppliers consider certain information to be proprietary, and thus CAS numbers and other limited information may not be available for release.

In no event shall CEL’s liability arising out of such information exceed the total purchase price of the CEL part(s) at issue sold by CEL to customer on an annual basis.

See CEL Terms and Conditions for additional clarification of warranties and liability.