



Chipsmall Limited consists of a professional team with an average of over 10 year of expertise in the distribution of electronic components. Based in Hongkong, we have already established firm and mutual-benefit business relationships with customers from,Europe,America and south Asia,supplying obsolete and hard-to-find components to meet their specific needs.

With the principle of "Quality Parts,Customers Priority,Honest Operation,and Considerate Service",our business mainly focus on the distribution of electronic components. Line cards we deal with include Microchip,ALPS,ROHM,Xilinx,Pulse,ON,Everlight and Freescale. Main products comprise IC,Modules,Potentiometer,IC Socket,Relay,Connector.Our parts cover such applications as commercial,industrial, and automotives areas.

We are looking forward to setting up business relationship with you and hope to provide you with the best service and solution. Let us make a better world for our industry!



## Contact us

Tel: +86-755-8981 8866 Fax: +86-755-8427 6832

Email & Skype: info@chipsmall.com Web: www.chipsmall.com

Address: A1208, Overseas Decoration Building, #122 Zhenhua RD., Futian, Shenzhen, China



# PS9851-1, PS9851-2

HIGH NOISE REDUCTION, 15 Mbps CMOS OUTPUT TYPE  
8-PIN SSOP (SO-8) HIGH-SPEED PHOTOCOUPLER

R08DS0107EJ0400  
Rev4.00  
Apr 09, 2013

## DESCRIPTION

The PS9851-1, PS9851-2 are optically coupled isolators containing GaAlAs LED on the input side and a CMOS output IC on the output side. They are high common mode transient immunity (CMR), high-speed CMOS output type photocouplers designed for high-speed logic interface circuits.

## FEATURES

- High-speed response (15 Mbps)
- Operable at high temperature (-40 to +100°C)
- High common mode transient immunity ( $CM_H, CM_L = \pm 20 \text{ kV}/\mu\text{s}$  TYP.)
- High isolation voltage ( $BV = 2\,500 \text{ V r.m.s.}$ )
- Pulse width distortion ( $|t_{PHL} - t_{PLH}| = 3 \text{ ns}$  TYP.)
- Ordering number of tape product : PS9851-1-F3: 1 500 pcs/reel
- : PS9851-2-F3: 1 500 pcs/reel
- Pb-Free product
- <R> • Safety standards
  - UL approved: No. E72422
  - DIN EN 60747-5-5 (VDE 0884-5) approved (Option)

## APPLICATIONS

- FA Network
- Measurement equipment
- PDP

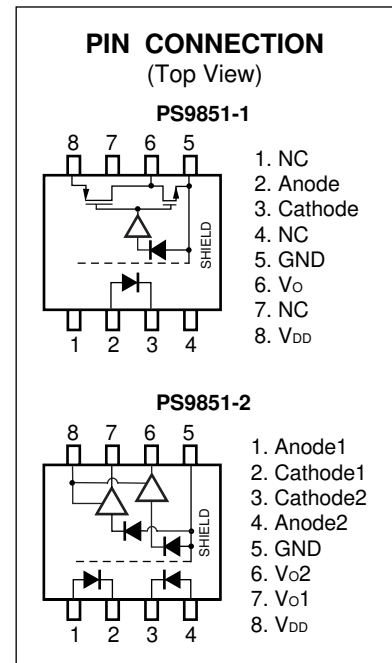

The mark <R> shows major revised points.

The revised points can be easily searched by copying an "<R>" in the PDF file and specifying it in the "Find what:" field.

**PACKAGE DIMENSIONS (UNIT: mm)**

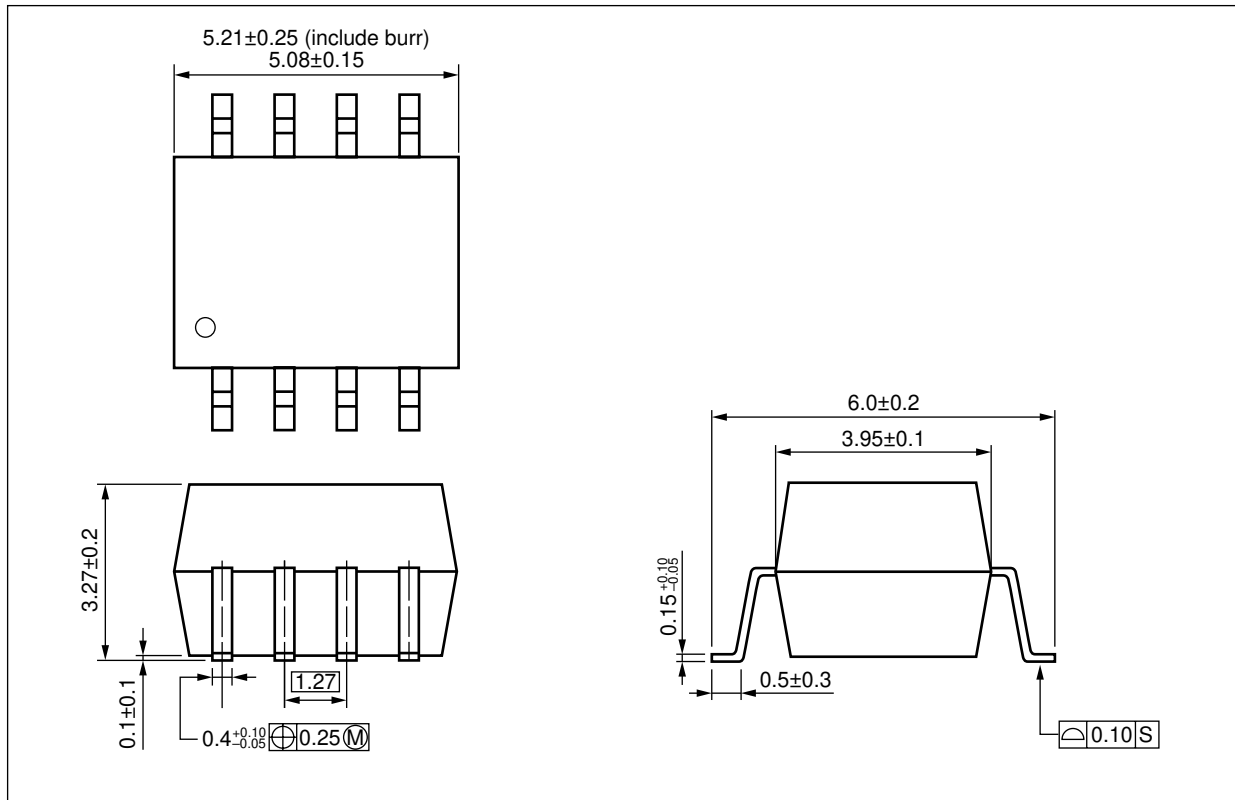

<R> **PHOTOCOUPLER CONSTRUCTION**

Parameter	Unit (MIN.)
Air Distance	4.0 mm
Outer Creepage Distance	4.0 mm
Isolation Distance	0.2 mm

<R> MARKING EXAMPLE

Ni/Pd/Au PLATING

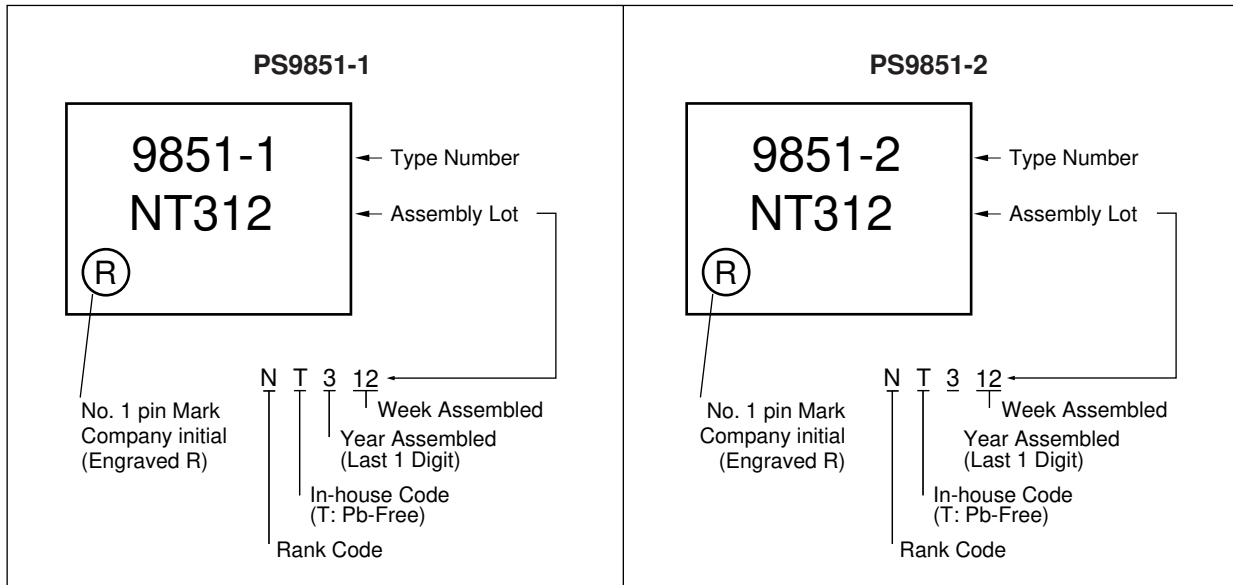

## &lt;R&gt; ORDERING INFORMATION

Part Number	Order Number	Solder Plating Specification	Packing Style	Safety Standard Approval	Application Part Number <sup>*1</sup>
PS9851-1	PS9851-1-AX	Pb-Free (Ni/Pd/Au)	20 pcs (Tape 20 pcs cut)	Standard products (UL approved)	PS9851-1
PS9851-1-F3	PS9851-1-F3-AX		Embossed Tape 1 500 pcs/reel		
PS9851-2	PS9851-2-AX		20 pcs (Tape 20 pcs cut)		PS9851-2
PS9851-2-F3	PS9851-2-F3-AX		Embossed Tape 1 500 pcs/reel		
PS9851-1-V	PS9851-1-V-AX		20 pcs (Tape 20 pcs cut)	DIN EN 60747-5-5 (VDE 0884-5)	PS9851-1
PS9851-1-V-F3	PS9851-1-V-F3-AX		Embossed Tape 1 500 pcs/reel		
PS9851-2-V	PS9851-2-V-AX		20 pcs (Tape 20 pcs cut)	approved(Optional)	PS9851-2
PS9851-2-V-F3	PS9851-2-V-F3-AX		Embossed Tape 1 500 pcs/reel		

Note: \*1. For the application of the Safety Standard, following part number should be used.

**ABSOLUTE MAXIMUM RATINGS (T<sub>A</sub> = 25°C, unless otherwise specified)**

Parameter		Symbol	Ratings	Unit
Diode	Forward Current <sup>*1</sup>	I <sub>F</sub>	20	mA
	Reverse Voltage	V <sub>R</sub>	5	V
Detector	Supply Voltage	V <sub>DD</sub>	0 to 5.5	V
	Output Voltage	V <sub>O</sub>	-0.5 to V <sub>DD</sub> +0.5	V
	Output Current	I <sub>O</sub>	2	mA
Isolation Voltage <sup>*2</sup>		BV	2 500	Vr.m.s.
Operating Ambient Temperature		T <sub>A</sub>	-40 to +100	°C
Storage Temperature		T <sub>stg</sub>	-55 to +125	°C

Notes: \*1. Reduced to 0.33 mA/°C at T<sub>A</sub> = 85°C or more for PS9851-2.

\*2. AC voltage for 1 minute at T<sub>A</sub> = 25°C, RH = 60% between input and output.

Pins 1-4 shorted together, 5-8 shorted together.

**RECOMMENDED OPERATING CONDITIONS (T<sub>A</sub> = 25°C)**

Parameter	Symbol	MIN.	TYP.	MAX.	Unit
Forward Current	I <sub>F</sub>	10		16	mA
Supply Voltage	V <sub>DD</sub>	4.5	5.0	5.5	V

<R> **ELECTRICAL CHARACTERISTICS** ( $T_A = -40$  to  $+100^\circ\text{C}$ ,  $V_{DD} = 4.5$  to  $5.5$  V, unless otherwise specified)

Parameter		Symbol	Conditions	MIN.	TYP.*1	MAX.	Unit		
Diode	Forward Voltage	$V_F$	$I_F = 10$ mA, $T_A = 25^\circ\text{C}$		1.6	1.9	V		
	Reverse Current	$I_R$	$V_R = 3$ V, $T_A = 25^\circ\text{C}$			10	$\mu\text{A}$		
	Terminal Capacitance	$C_t$	$V = 0$ V, $f = 1$ MHz, $T_A = 25^\circ\text{C}$		30		pF		
Detector	High Level Supply Current	$I_{DDH}$	$I_F = 0$ mA (1ch)		2.5	5	mA/ch		
	Low Level Supply Current	$I_{DDL}$	$I_F = 10$ mA (1ch)		2	5			
	High Level Output Voltage	$V_{OH}$	$I_O = -20\mu\text{A}$ , $I_F = 0$ mA	4.0	5.0		V		
	Low Level Output Voltage	$V_{OL}$	$I_O = 20\mu\text{A}$ , $I_F = 10$ mA		0	0.1			
Coupled	Threshold Input Voltage	$I_{FHL}$	$V_O < 1$ V		2.8	6	mA		
	Isolation Resistance	$R_{I-O}$	$V_{I-O} = 1$ kV <sub>DC</sub> , RH = 40 to 60%, $T_A = 25^\circ\text{C}$	$10^{11}$			$\Omega$		
	Isolation Capacitance	$C_{I-O}$	$V = 0$ V, $f = 1$ MHz, $T_A = 25^\circ\text{C}$		0.6		pF		
	Propagation Delay Time (H $\rightarrow$ L) <sup>*2</sup>	$t_{PHL}$	$I_F = 10$ mA, $V_{DD} = 5$ V, $C_L = 15$ pF, CMOS Levels		34	60	ns		
	Propagation Delay Time (L $\rightarrow$ H) <sup>*2</sup>	$t_{PLH}$			37	60			
	Pulse Width Distortion (PWD) <sup>*2</sup>	$ t_{PHL} - t_{PLH} $			3	30			
	Propagation Delay Skew	$t_{PSK}$				40			
	Rise Time	$t_r$			4				
	Fall Time	$t_f$			4				
	Common Mode Transient Immunity at High Level Output <sup>*3</sup>	$ CM_H $		$V_{DD} = 5$ V, $I_F = 0$ mA, $V_{CM} = 1$ kV, $V_O > 4$ V, $T_A = 25^\circ\text{C}$	10	20			kV/ $\mu\text{s}$
	Common Mode Transient Immunity at Low Level Output <sup>*3</sup>	$ CM_L $		$V_{DD} = 5$ V, $I_F = 10$ mA, $V_{CM} = 1$ kV, $V_O < 1$ V, $T_A = 25^\circ\text{C}$	10	20			

## PS9851-1, PS9851-2

Notes: \*1. Typical values at  $T_A = 25^\circ\text{C}$

\*2 Test circuit for propagation delay time

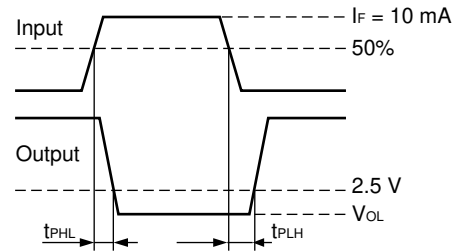
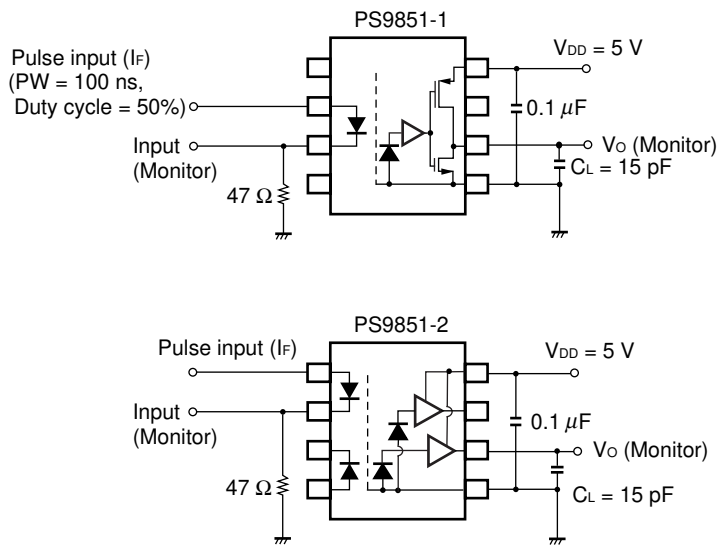

**Remark**  $C_L$  includes probe and stray wiring capacitance.

Notes: \* 3 Test circuit for common mode transient immunity

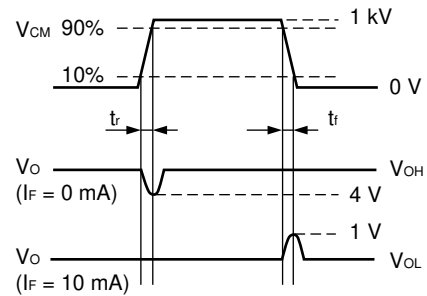
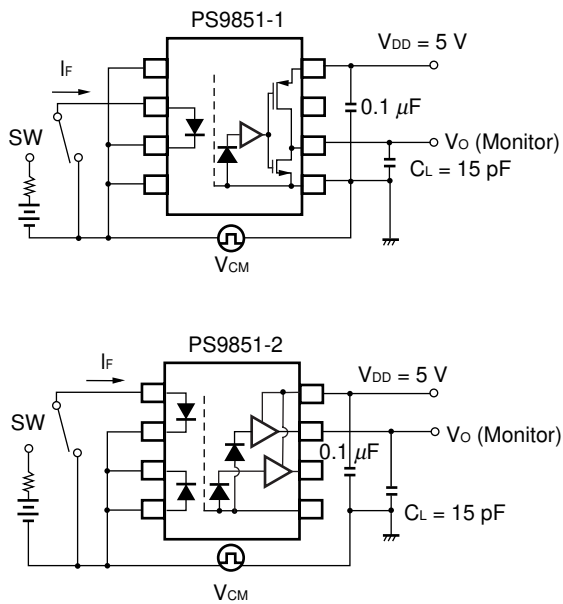

**Remark**  $C_L$  includes probe and stray wiring capacitance.

**TYPICAL CHARACTERISTICS (T<sub>A</sub> = 25°C, unless otherwise specified)**

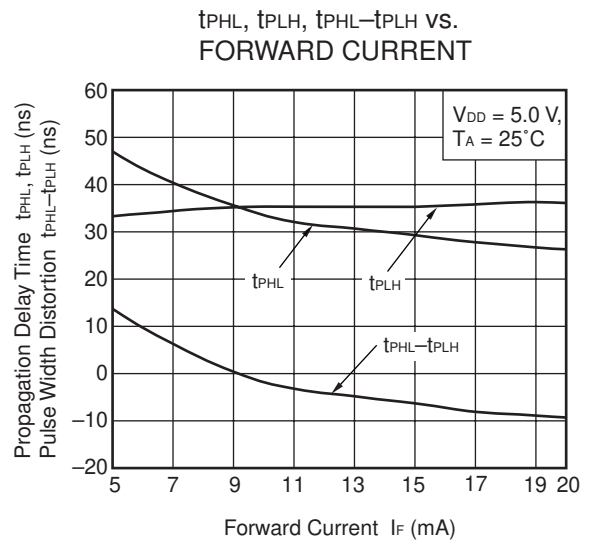
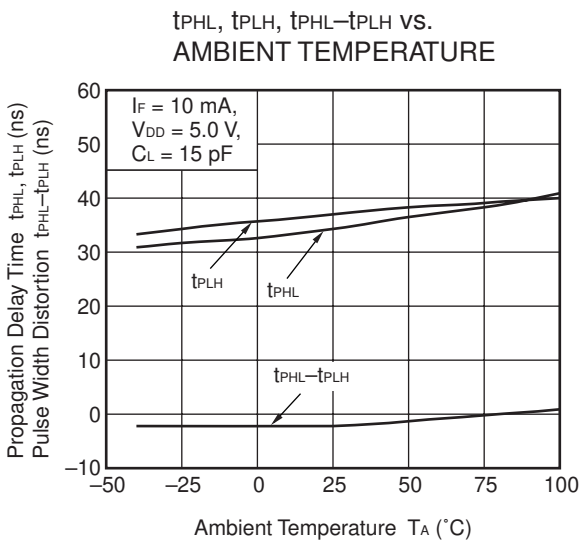
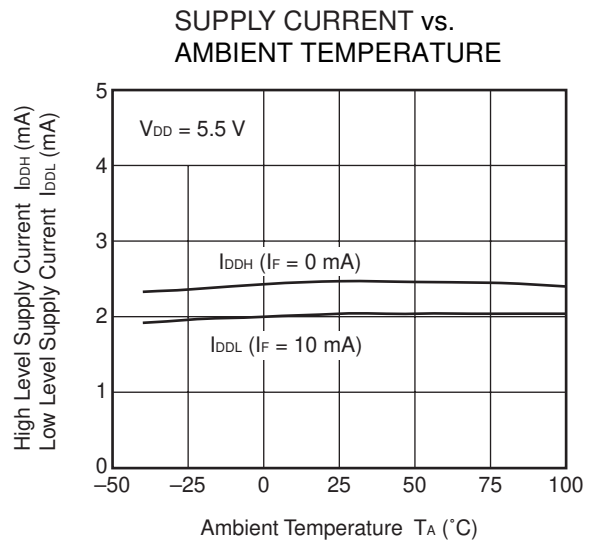
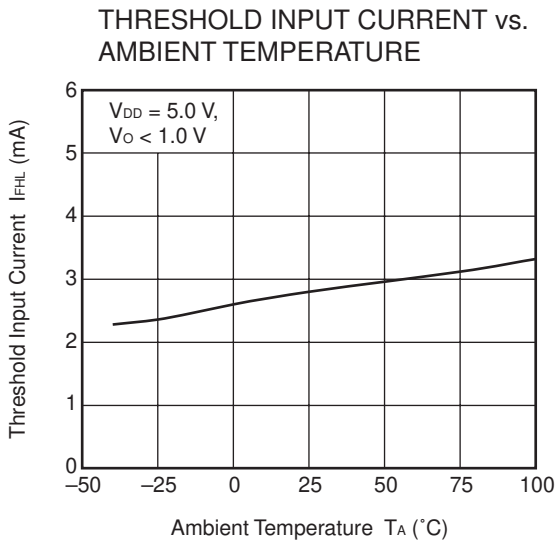
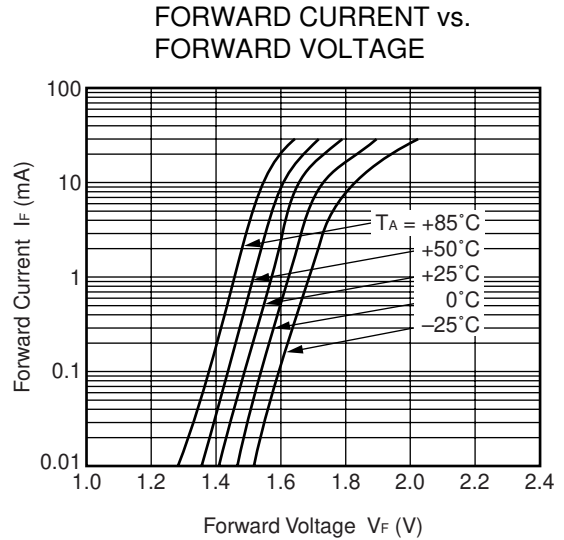
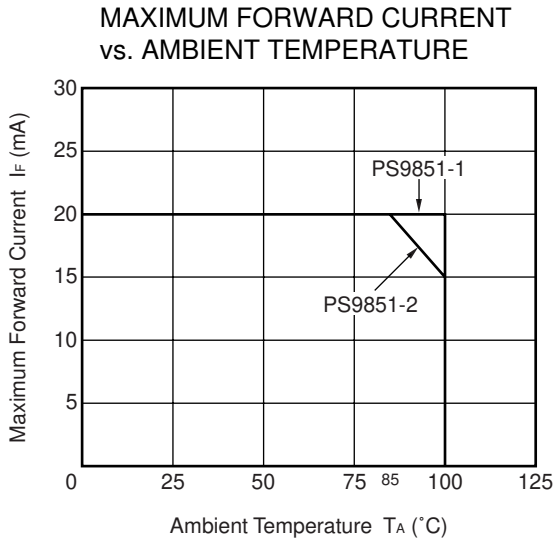

**Remark** The graphs indicate nominal characteristics.



<R> TAPING SPECIFICATIONS (UNIT: mm)

Outline and Dimensions (Tape)

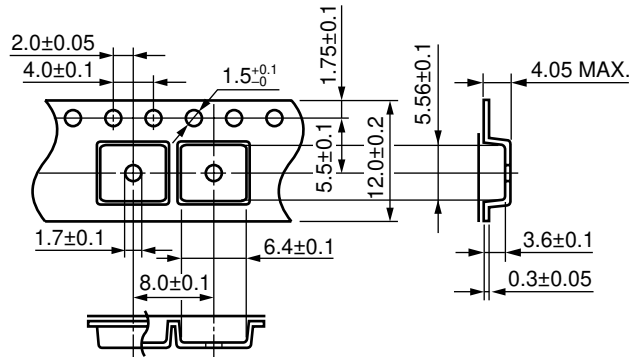

Taping Direction

PS9851-1-F3  
PS9851-2-F3

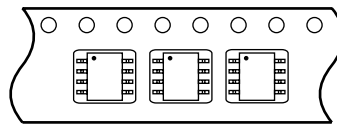

Outline and Dimensions (Reel)

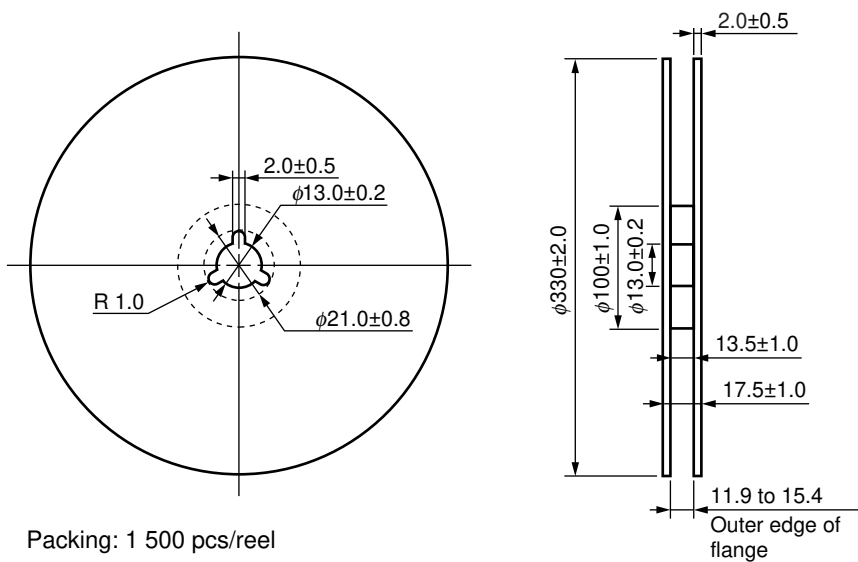

Packing: 1 500 pcs/reel

RECOMMENDED MOUNT PAD DIMENSIONS (UNIT: mm)

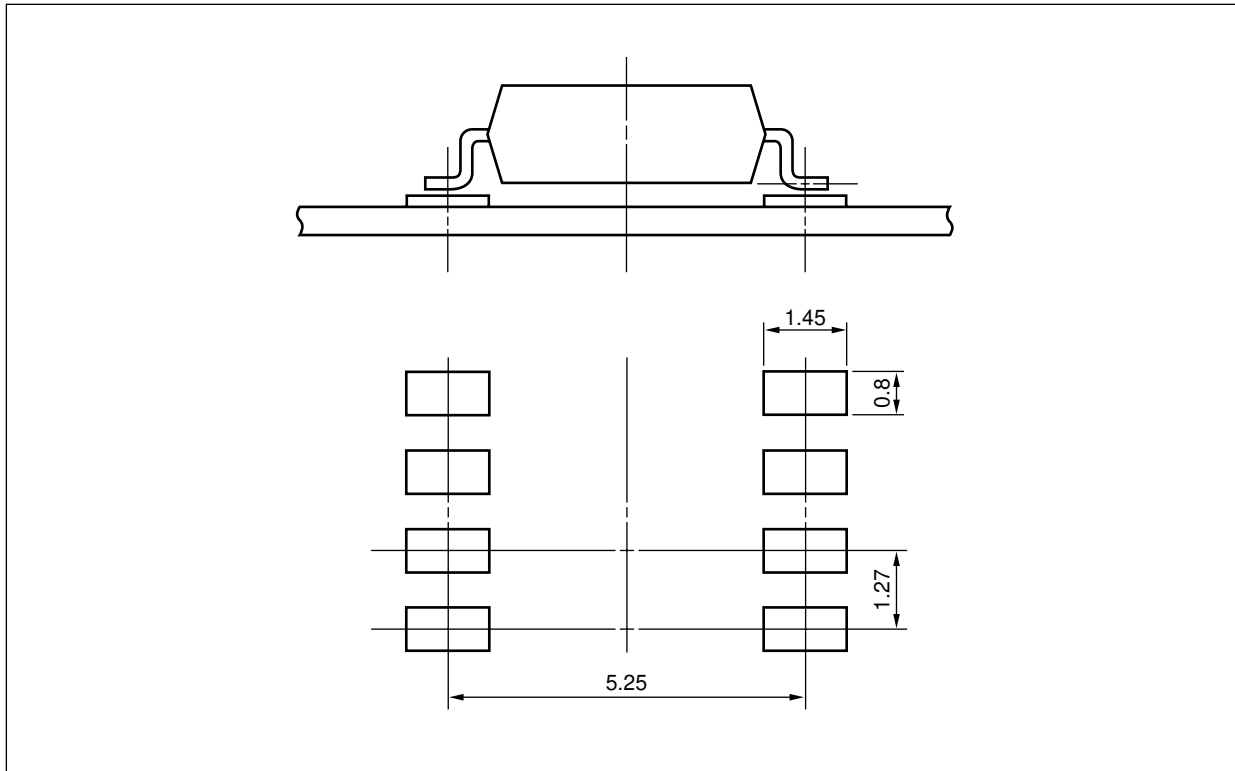

<R> **NOTES ON HANDLING**

## 1. Recommended soldering conditions

## (1) Infrared reflow soldering

- Peak reflow temperature 260°C or below (package surface temperature)
- Time of peak reflow temperature 10 seconds or less
- Time of temperature higher than 220°C 60 seconds or less
- Time to preheat temperature from 120 to 180°C 120±30 s
- Number of reflows Three
- Flux Rosin flux containing small amount of chlorine (The flux with a maximum chlorine content of 0.2 Wt% is recommended.)

Recommended Temperature Profile of Infrared Reflow

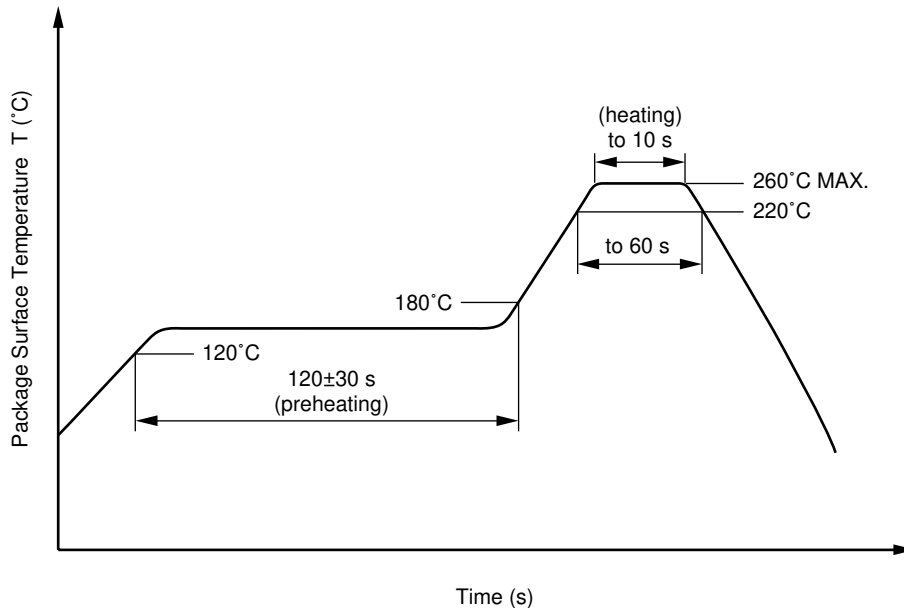

## (2) Wave soldering

- Temperature 260°C or below (molten solder temperature)
- Time 10 seconds or less
- Preheating conditions 120°C or below (package surface temperature)
- Number of times One (Allowed to be dipped in solder including plastic mold portion.)
- Flux Rosin flux containing small amount of chlorine (The flux with a maximum chlorine content of 0.2 Wt% is recommended.)

## (3) Soldering by Soldering Iron

- Peak Temperature (lead part temperature) 350°C or below
- Time (each pin) 3 seconds or less
- Flux Rosin flux containing small amount of chlorine (The flux with a maximum chlorine content of 0.2 Wt% or less is recommended.)

(a) Soldering of leads should be made at the point 1.5 to 2.0 mm from the root of the lead.

## (4) Cautions

- Fluxes  
Avoid removing the residual flux with freon-based and chlorine-based cleaning solvent.

## 2. Cautions Regarding Noise

Be aware that when voltage is applied suddenly between the photocoupler's input and output at startup, the CMOS IC on output side may enter the on state, even if the voltage is within the absolute maximum ratings.

## USAGE CAUTIONS

1. This product is weak for static electricity by designed with high-speed integrated circuit so protect against static electricity when handling.
2. By-pass capacitor of more than 0.1  $\mu\text{F}$  is used between VDD and GND near device. Also, ensure that the distance between the leads of the photocoupler and capacitor is no more than 10 mm.
- <R> 3. When  $V_{\text{DD}}$  is lower than around 2 V, the output( $V_{\text{o}}$ ) of this product is unstable, and this might produce undesirable operation. Be sure to check the operation of an IC or a discrete component that is connected to this product during Power-up and Power-down process. And we recommend to use a disable function (shutdown function ) of the connected IC or a reset IC to avoid this undesirable operation.
4. Avoid storage at a high temperature and high humidity.

## &lt;R&gt; SPECIFICATION OF VDE MARKS LICENSE DOCUMENT

Parameter	Symbol	Spec.	Unit
Climatic test class (IEC 60068-1/DIN EN 60068-1)		40/100/21	
Dielectric strength maximum operating isolation voltage Test voltage (partial discharge test, procedure a for type test and random test) $U_{pr} = 1.6 \times U_{IORM}, P_d < 5 \text{ pC}$	$U_{IORM}$ $U_{pr}$	566 905	$V_{peak}$ $V_{peak}$
Test voltage (partial discharge test, procedure b for all devices) $U_{pr} = 1.875 \times U_{IORM}, P_d < 5 \text{ pC}$	$U_{pr}$	1 061	$V_{peak}$
Highest permissible overvoltage	$U_{TR}$	4 000	$V_{peak}$
Degree of pollution (DIN EN 60664-1 VDE0110 Part 1)		2	
Comparative tracking index (IEC 60112/DIN EN 60112(VDE 0303 Part11))	CTI	175	
Material group (DIN EN 60664-1 VDE0110 Part 1)		III a	
Storage temperature range	$T_{stg}$	-55 to +125	°C
Operating temperature range	$T_A$	-40 to +100	°C
Isolation resistance, minimum value $V_{IO} = 500 \text{ V dc at } T_A = 25^\circ\text{C}$ $V_{IO} = 500 \text{ V dc at } T_A \text{ MAX. at least } 100^\circ\text{C}$	Ris MIN. Ris MIN.	$10^{12}$ $10^{11}$	$\Omega$ $\Omega$
Safety maximum ratings (maximum permissible in case of fault, see thermal derating curve) Package temperature Current (input current $I_F$ , $P_{si} = 0$ ) Power (output or total power dissipation) Isolation resistance $V_{IO} = 500 \text{ V dc at } T_A = T_{si}$	$T_{si}$ $I_{si}$ $P_{si}$ Ris MIN.	150 150 600 $10^9$	°C mA mW $\Omega$

<b>Caution</b>	GaAs Products	<p>This product uses gallium arsenide (GaAs). GaAs vapor and powder are hazardous to human health if inhaled or ingested, so please observe the following points.</p> <ul style="list-style-type: none"><li>• Follow related laws and ordinances when disposing of the product. If there are no applicable laws and/or ordinances, dispose of the product as recommended below.<ol style="list-style-type: none"><li>1. Commission a disposal company able to (with a license to) collect, transport and dispose of materials that contain arsenic and other such industrial waste materials.</li><li>2. Exclude the product from general industrial waste and household garbage, and ensure that the product is controlled (as industrial waste subject to special control) up until final disposal.</li></ol></li><li>• Do not burn, destroy, cut, crush, or chemically dissolve the product.</li><li>• Do not lick the product or in any way allow it to enter the mouth.</li></ul>
----------------	---------------	--

**Revision History****PS9851-1, PS9851-2 Data Sheet**

<b>Rev.</b>	<b>Date</b>	<b>Description</b>	
		<b>Page</b>	<b>Summary</b>
1.00	Jun 21, 2004	–	First edition issued
2.00	Aug 22, 2008	–	Second edition issued
3.00	Aug 27, 2008	–	Third edition issued
4.00	Apr 09, 2013	Throughout	Renesas format is applied to this data sheet.
		p.1	Modification of FEATURES
		p.2	Addition of PHOTOCOUPLER CONSTRUCTION
		p.3	Modification of MARKING EXAMPLE
		p.4	Modification of ORDERING INFORMATION
		pp.5, 6	Modification of ELECTRICAL CHARACTERISTICS
		p.8	Modification of TAPING SPECIFICATIONS
		pp.10, 11	Modification of NOTES ON HANDLING
p.12	Modification of SPECIFICATION OF VDE MARKS LICENSE DOCUMENT		

All trademarks and registered trademarks are the property of their respective owners.

## Notice

1. Descriptions of circuits, software and other related information in this document are provided only to illustrate the operation of semiconductor products and application examples. You are fully responsible for the incorporation of these circuits, software, and information in the design of your equipment. Renesas Electronics assumes no responsibility for any losses incurred by you or third parties arising from the use of these circuits, software, or information.
2. Renesas Electronics has used reasonable care in preparing the information included in this document, but Renesas Electronics does not warrant that such information is error free. Renesas Electronics assumes no liability whatsoever for any damages incurred by you resulting from errors in or omissions from the information included herein.
3. Renesas Electronics does not assume any liability for infringement of patents, copyrights, or other intellectual property rights of third parties by or arising from the use of Renesas Electronics products or technical information described in this document. No license, express, implied or otherwise, is granted hereby under any patents, copyrights or other intellectual property rights of Renesas Electronics or others.
4. You should not alter, modify, copy, or otherwise misappropriate any Renesas Electronics product, whether in whole or in part. Renesas Electronics assumes no responsibility for any losses incurred by you or third parties arising from such alteration, modification, copy or otherwise misappropriation of Renesas Electronics product.
5. Renesas Electronics products are classified according to the following two quality grades: "Standard" and "High Quality". The recommended applications for each Renesas Electronics product depends on the product's quality grade, as indicated below.  
"Standard": Computers; office equipment; communications equipment; test and measurement equipment; audio and visual equipment; home electronic appliances; machine tools; personal electronic equipment; and industrial robots etc.  
"High Quality": Transportation equipment (automobiles, trains, ships, etc.); traffic control systems; anti-disaster systems; anti-crime systems; and safety equipment etc.  
Renesas Electronics products are neither intended nor authorized for use in products or systems that may pose a direct threat to human life or bodily injury (artificial life support devices or systems, surgical implantations etc.), or may cause serious property damages (nuclear reactor control systems, military equipment etc.). You must check the quality grade of each Renesas Electronics product before using it in a particular application. You may not use any Renesas Electronics product for any application for which it is not intended. Renesas Electronics shall not be in any way liable for any damages or losses incurred by you or third parties arising from the use of any Renesas Electronics product for which the product is not intended by Renesas Electronics.
6. You should use the Renesas Electronics products described in this document within the range specified by Renesas Electronics, especially with respect to the maximum rating, operating supply voltage range, movement power voltage range, heat radiation characteristics, installation and other product characteristics. Renesas Electronics shall have no liability for malfunctions or damages arising out of the use of Renesas Electronics products beyond such specified ranges.
7. Although Renesas Electronics endeavors to improve the quality and reliability of its products, semiconductor products have specific characteristics such as the occurrence of failure at a certain rate and malfunctions under certain use conditions. Further, Renesas Electronics products are not subject to radiation resistance design. Please be sure to implement safety measures to guard them against the possibility of physical injury, and injury or damage caused by fire in the event of the failure of a Renesas Electronics product, such as safety design for hardware and software including but not limited to redundancy, fire control and malfunction prevention, appropriate treatment for aging degradation or any other appropriate measures. Because the evaluation of microcomputer software alone is very difficult, please evaluate the safety of the final products or systems manufactured by you.
8. Please contact a Renesas Electronics sales office for details as to environmental matters such as the environmental compatibility of each Renesas Electronics product. Please use Renesas Electronics products in compliance with all applicable laws and regulations that regulate the inclusion or use of controlled substances, including without limitation, the EU RoHS Directive. Renesas Electronics assumes no liability for damages or losses occurring as a result of your noncompliance with applicable laws and regulations.
9. Renesas Electronics products and technology may not be used for or incorporated into any products or systems whose manufacture, use, or sale is prohibited under any applicable domestic or foreign laws or regulations. You should not use Renesas Electronics products or technology described in this document for any purpose relating to military applications or use by the military, including but not limited to the development of weapons of mass destruction. When exporting the Renesas Electronics products or technology described in this document, you should comply with the applicable export control laws and regulations and follow the procedures required by such laws and regulations.
10. It is the responsibility of the buyer or distributor of Renesas Electronics products, who distributes, disposes of, or otherwise places the product with a third party, to notify such third party in advance of the contents and conditions set forth in this document, Renesas Electronics assumes no responsibility for any losses incurred by you or third parties as a result of unauthorized use of Renesas Electronics products.
11. This document may not be reproduced or duplicated in any form, in whole or in part, without prior written consent of Renesas Electronics.
12. Please contact a Renesas Electronics sales office if you have any questions regarding the information contained in this document or Renesas Electronics products, or if you have any other inquiries.  
(Note 1) "Renesas Electronics" as used in this document means Renesas Electronics Corporation and also includes its majority-owned subsidiaries.  
(Note 2) "Renesas Electronics product(s)" means any product developed or manufactured by or for Renesas Electronics.



### SALES OFFICES

Renesas Electronics Corporation

<http://www.renesas.com>

Refer to "<http://www.renesas.com/>" for the latest and detailed information.

**California Eastern Laboratories, Inc.**  
4590 Patrick Henry Drive, Santa Clara, California 95054, U.S.A.  
Tel: +1-408-919-2500, Fax: +1-408-988-0279

**Renesas Electronics Europe Limited**  
Dukes Meadow, Millboard Road, Bourne End, Buckinghamshire, SL8 5FH, U.K  
Tel: +44-1628-651-700, Fax: +44-1628-651-804

**Renesas Electronics Europe GmbH**  
Arcadiastrasse 10, 40472 Düsseldorf, Germany  
Tel: +49-211-65030, Fax: +49-211-6503-1327

**Renesas Electronics (China) Co., Ltd.**  
7th Floor, Quantum Plaza, No.27 ZhiChunLu Haidian District, Beijing 100083, P.R.China  
Tel: +86-10-8235-1155, Fax: +86-10-8235-7679

**Renesas Electronics (Shanghai) Co., Ltd.**  
Unit 204, 205, AZIA Center, No.1233 Lujiazui Ring Rd., Pudong District, Shanghai 200120, China  
Tel: +86-21-5877-1818, Fax: +86-21-6887-7858 / -7898

**Renesas Electronics Hong Kong Limited**  
Unit 1601-1613, 16/F., Tower 2, Grand Century Place, 193 Prince Edward Road West, Mongkok, Kowloon, Hong Kong  
Tel: +852-2886-9318, Fax: +852 2886-9022/9044

**Renesas Electronics Taiwan Co., Ltd.**  
13F, No. 363, Fu Shing North Road, Taipei, Taiwan  
Tel: +886-2-8175-9600, Fax: +886 2-8175-9670

**Renesas Electronics Singapore Pte. Ltd.**  
80 Bendemeer Road, Unit #06-02 Hyflux Innovation Centre Singapore 339949  
Tel: +65-6213-0200, Fax: +65-6213-0300

**Renesas Electronics Malaysia Sdn.Bhd.**  
Unit 906, Block B, Menara Amcorp, Amcorp Trade Centre, No. 18, Jln Persiaran Barat, 46050 Petaling Jaya, Selangor Darul Ehsan, Malaysia  
Tel: +60-3-7955-9390, Fax: +60-3-7955-9510

**Renesas Electronics Korea Co., Ltd.**  
11F., Samik Lavied' or Bldg., 720-2 Yeoksam-Dong, Kangnam-Ku, Seoul 135-080, Korea  
Tel: +82-2-558-3737, Fax: +82-2-558-5141