



Chipsmall Limited consists of a professional team with an average of over 10 year of expertise in the distribution of electronic components. Based in Hongkong, we have already established firm and mutual-benefit business relationships with customers from,Europe,America and south Asia,supplying obsolete and hard-to-find components to meet their specific needs.

With the principle of “Quality Parts,Customers Priority,Honest Operation,and Considerate Service”,our business mainly focus on the distribution of electronic components. Line cards we deal with include Microchip,ALPS,ROHM,Xilinx,Pulse,ON,Everlight and Freescale. Main products comprise IC,Modules,Potentiometer,IC Socket,Relay,Connector.Our parts cover such applications as commercial,industrial, and automotives areas.

We are looking forward to setting up business relationship with you and hope to provide you with the best service and solution. Let us make a better world for our industry!



Contact us

Tel: +86-755-8981 8866 Fax: +86-755-8427 6832

Email & Skype: info@chipsmall.com Web: www.chipsmall.com

Address: A1208, Overseas Decoration Building, #122 Zhenhua RD., Futian, Shenzhen, China





Single Port 15.4W Power over Ethernet Adapter PSA16U IEEE 802.3af Compliant

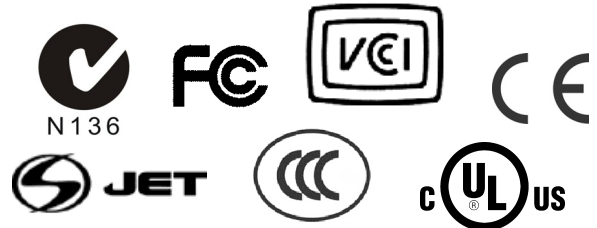

Features

- Fully Compliant Detection, Disconnect, Overload and Voltage Control IEEE802.3af
- Data and Power Carried over One Ethernet Cable
- Internal Signature Resistance IEEE802.3 standard
- UNH IOL Test Report
- Diagnostic LEDs
- Full Protection OTP, OCP, OVP
- Non-Vented Case
- Guaranteed Protection
- 1 Year Warranty

Applications

- IP Telephones
- Wireless Network Access Points
- Blue Tooth Access Points
- Security Cameras
- IP Print Servers

Safety Approvals

- cUL/UL
- CE
- CCC
- S-Jet
- SAA
- FCC
- VCCI
- C-Tick

Mechanical Characteristics

- Length: 140mm (5.51in)
- Width: 65mm (2.55in)
- Height: 36mm (1.42in)
- Weight: 0.2Kg (0.44lb.)

Output Specifications

Model	DC Output Voltage	Load		Regulation	
		Min.	Max.	Line	Load
PSA16U-480(POE)	48V	0A	0.32A	±4%	

Phihong is not responsible for any error, and reserves the right to make changes without notice. Please visit our website at www.phihong.com for the most up-to-date specifications and contact information.

INPUT:**AC Input Voltage Range**

90 to 264VAC

AC Input Voltage Rating

100 to 240VAC

AC Input Current

0.5A (RMS) maximum for 90VAC

0.35 A(RMS) maximum for 240VAC

Leakage Current

0.25mA maximum @ 254VAC 60Hz

AC Input Frequency

47-63Hz

AC Inrush Current

15A (RMS) maximum for 115VAC

20A (RMS) maximum for 230VAC

OUTPUT:**Total Output Power**

15.4W

Ripple and Regulation

100mV maximum

Efficiency

65% (typical) at maximum load, and 120VAC 60Hz

Hold-up Time

16mS min. 120VAC and maximum load

Transient O/P Voltage Protection

60V maximum at switch on and off at any AC line Phase

ENVIRONMENTAL:**Temperature**

Operation 0 to +40°C

Non-operation -25 to +65°C

Humidity

Operation 5 to 90%

EMC

FCC Part 15 Class B

EN55022 Class B

VCCI, C-Tick

Isolation Test

Primary to Secondary: 3000VAC for 1 minute 10mA

Primary to Field Ground: 1500VAC for 1 minute

Output to Field Ground: 1500VAC

Immunity EN50082-1

ESD: EN61000-4-2. Level 3

RS: EN61000-4-3. Level 2

EFT: EN61000-4-4. Level 2

Surge: EN61000-4-5. Level 3

CS: EN61000-4-6. Level 2

Voltage Dips EN61000-4-11

Harmonic: EN61000-3-2

Insulation Resistance

Primary to Secondary: >10M OHM 500VDC

Primary to Field Ground: >10M OHM 500VDC

FEATURE:**Over Voltage/Current, Short Circuit Protection**

Outputs equipped with short circuit protection and overload protection as per 802.3af specifications

The output can be shorted permanently without damage

Indicators

Green LED 1: Power detected "ON"

Red LED: Fault detected

Green LED 2: Valid IEEE802.3af load detected and connected

Input Connector

IEC320 inlet 3 pin

Warranty

1 Year

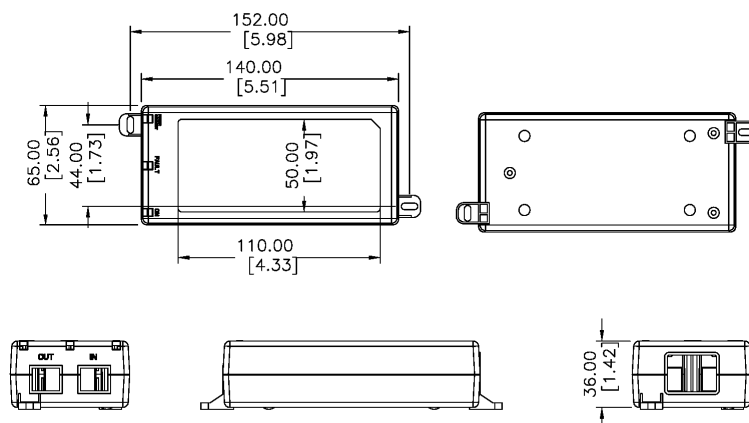
Dimension Diagram Unit: mm (inch)

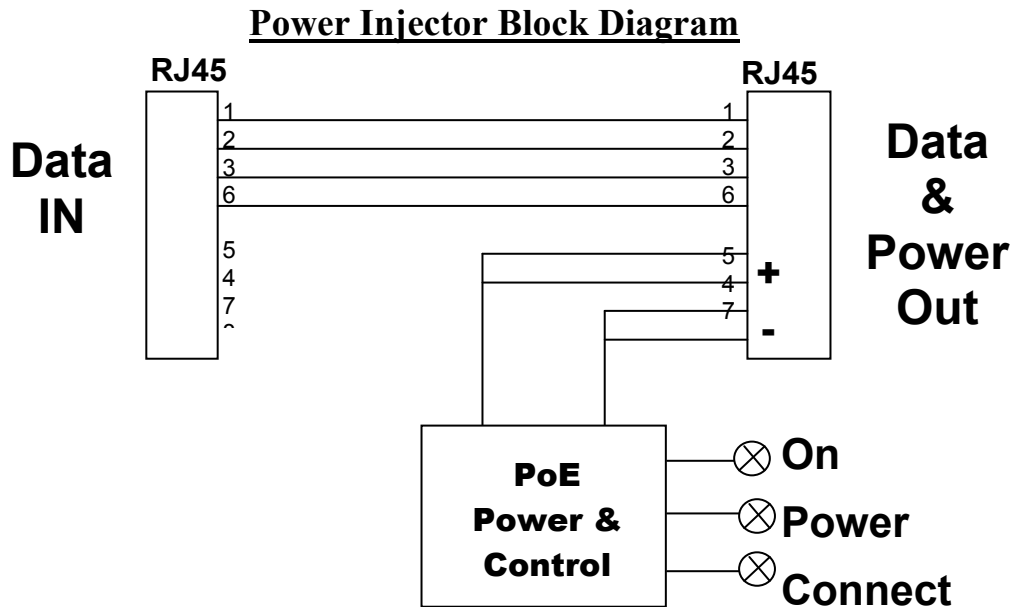

Description of LED Functions for Power Injector

Power-up Sequence:

Upon power-up, all 3 LEDs will light for 2 seconds, as part of the self-test for the internal microprocessor software. After the 2 second period, the "ON" LED will illuminate green. The DC output voltage is now available for powering a compliant load (to the 802.3af PoE standards).

Detection Sequence:

Once a compliant load is attached to the output RJ45 connector, the green "CONNECT" LED will illuminate.

Should the load be non-compliant then the LEDs will blink a code specific to the cause for non-detection.

Detection Failure Codes:

1. Incorrect resistive signature – The green "CONNECT" and red "FAULT" LEDs will blink 3 times.
2. Incorrect capacitive signature – The green "ON" LED will blink 3 times.
3. Incorrect Voffset – The green "CONNECT" and green "ON" LEDs will blink 3 times.
4. Unstable current measurement – The green "ON" LED will blink 3 times
5. Low voltage sensed during detection (overload) – The red "FAULT" LED will blink 3 times

After the LEDs blink 3 times the Power Injector will continue to try to detect a valid load. Until the correct load is applied, the LEDs will continue to blink. If there is an open circuit connected to the output RJ45 then the LEDs will not blink but the Power Injector will continue to try to detect a valid load.

Fault Sequence:

Should there be a fault such as an overload or short circuit then the red "FAULT" LED will illuminate. The red "FAULT" LED will illuminate for 2 seconds and then go off as the power supply tries to re-detect a valid load. If there is a problem detecting the load, the LEDs will indicate a possible fault as per the codes in the section above.