



Chipsmall Limited consists of a professional team with an average of over 10 year of expertise in the distribution of electronic components. Based in Hongkong, we have already established firm and mutual-benefit business relationships with customers from,Europe,America and south Asia,supplying obsolete and hard-to-find components to meet their specific needs.

With the principle of "Quality Parts,Customers Priority,Honest Operation,and Considerate Service",our business mainly focus on the distribution of electronic components. Line cards we deal with include Microchip,ALPS,ROHM,Xilinx,Pulse,ON,Everlight and Freescale. Main products comprise IC,Modules,Potentiometer,IC Socket,Relay,Connector.Our parts cover such applications as commercial,industrial, and automotives areas.

We are looking forward to setting up business relationship with you and hope to provide you with the best service and solution. Let us make a better world for our industry!



Contact us

Tel: +86-755-8981 8866 Fax: +86-755-8427 6832

Email & Skype: info@chipsmall.com Web: www.chipsmall.com

Address: A1208, Overseas Decoration Building, #122 Zhenhua RD., Futian, Shenzhen, China



RJ45 Lock-in Device

specifications

The RJ45 Lock-in device shall work with most RJ45 patch cords, faceplates, patch panels and VoIP phones. Compact design shall not interfere with adjacent jacks or plugs. There shall be three available options: standard, recessed and super recessed. Each design shall allow the plug to be locked into or released from a jack with the help of a key.



technical information

Material:	Lock-In: Polycarbonate Key: Nylon
RoHS compliant:	Compliant

features and benefits

Tamper Resistant:	Prevents unauthorized removal of cable, IP phone, other networking equipment or critical connection; compatible with VoIP phones to deter unauthorized users from moving or stealing phones, helping maintain E911 availability and compliance.
Compact design:	Can be installed without interfering with adjacent jacks and plugs, even in high density applications
Installation Removal tool:	Allows plug to be locked or released from a jack providing physical security
Color assortment:	Enable color coding for visual identification; available in eight colors.
Saves time and money:	By reducing network downtime, security breaches and hardware replacement due to theft
Compatibility:	Works with most patch cords, faceplates and patch panels

applications

The Panduit RJ45 plug lock-in device secures connections to reduce network downtime, data security breaches, and hardware replacement due to theft.

The versatile design works with most patch cords, faceplates, patch panels, IP cameras and other IP devices. It is also compatible with VoIP phones to help prevent unauthorized removal and ensure E911 continuity. RJ45 Lock-In devices are available in three options:

Standard (Flushmount): ideal for installations where jack mounts flush with the surface, except for sloped faceplates

Recessed: used when jacks sit slightly recessed from the surface

Super Recessed: when jacks sit much deeper from the surface.

Standard (Flushmount) Lock-In Device

PSL-DCPLX (red)
PSL-DCPLX-C
PSL-DCPLX-**
PSL-DCPLX-**-C

Recessed Lock-In Device

PSL-DCPLRX (Red)
PSL-DCPLRX-C
PSL-DCPLRX-**
PSL-DCPLRX-**-C

Super Recessed Lock-In Device

PSL-DCPLS
PSL-DCPLS-C
PSL-DCPLS-BL
PSL-DCPLS-BL-C
PSL-DCPLS-GR
PSL-DCPLS-GR-C
PSL-DCPLS-YL

** For colors other than red, add suffix:
BL, BU, GR, IW, YL, OR, IG
Standard (Flushmount) devices have white cams, recessed devices have clear cams.
It is recommended to test your specific patch cords and jacks before implementing widespread usage.

RJ45 Lock-in Device

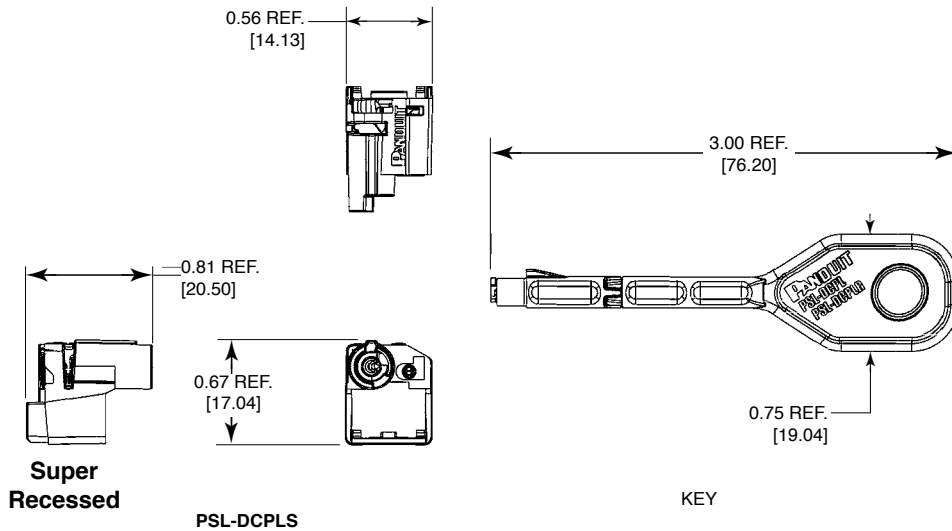
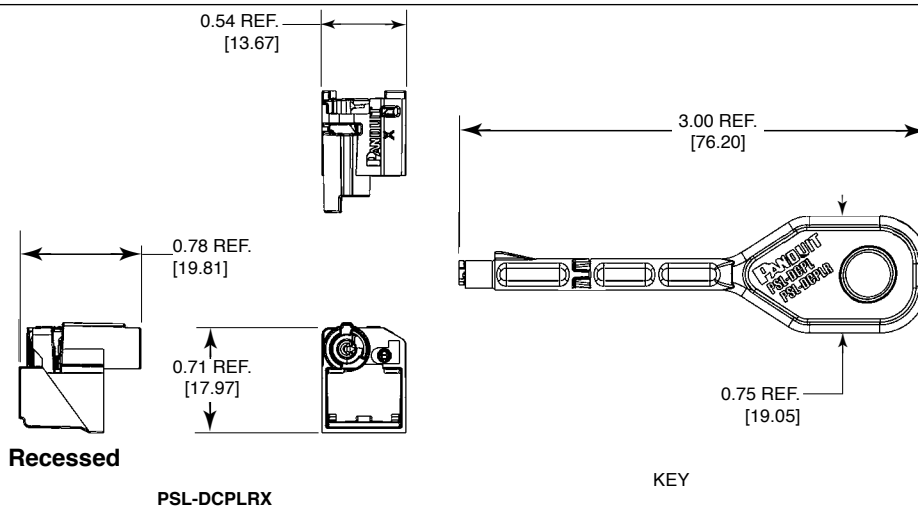
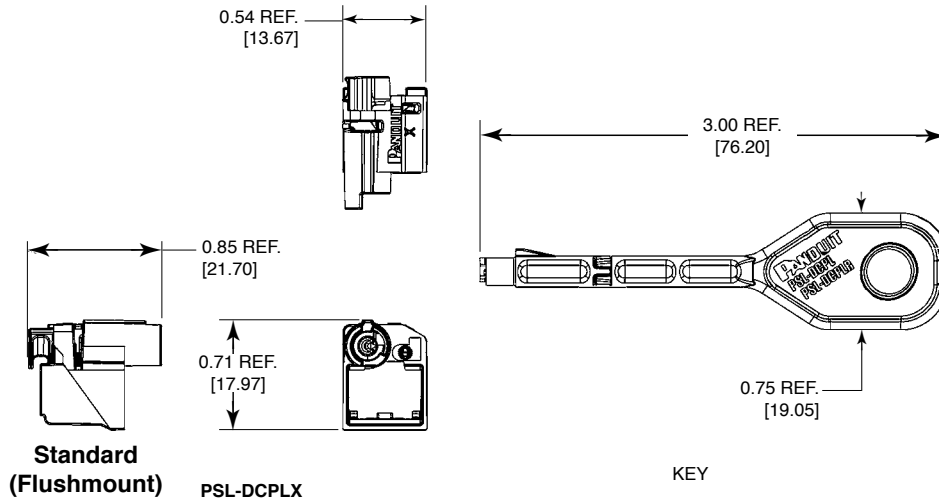

WORLDWIDE SUBSIDIARIES AND SALES OFFICES

PANDUIT CANADA
Markham, Ontario
cs-cdn@panduit.com
Phone: 800.777.3300

PANDUIT EUROPE LTD.
London, UK
cs-emea@panduit.com
Phone: 44.20.8601.7200

PANDUIT SINGAPORE PTE. LTD.
Republic of Singapore
cs-ap@panduit.com
Phone: 65.6305.7575

PANDUIT JAPAN
Tokyo, Japan
cs-japan@panduit.com
Phone: 81.3.6863.6000

PANDUIT LATIN AMERICA
Guadalajara, Mexico
cs-la@panduit.com
Phone: 52.33.3777.6000

PANDUIT AUSTRALIA PTY. LTD.
Victoria, Australia
cs-aus@panduit.com
Phone: 61.3.9794.9020

For a copy of Panduit product warranties, log on to www.panduit.com/warranty

For more information

Visit us at www.panduit.com

Contact Customer Service by email: cs@panduit.com
or by phone: 800.777.3300



©2016 Panduit Corp.
ALL RIGHTS RESERVED.
COSP391--WW-ENG
4/2016