



Chipsmall Limited consists of a professional team with an average of over 10 year of expertise in the distribution of electronic components. Based in Hongkong, we have already established firm and mutual-benefit business relationships with customers from,Europe,America and south Asia,supplying obsolete and hard-to-find components to meet their specific needs.

With the principle of “Quality Parts,Customers Priority,Honest Operation,and Considerate Service”,our business mainly focus on the distribution of electronic components. Line cards we deal with include Microchip,ALPS,ROHM,Xilinx,Pulse,ON,Everlight and Freescale. Main products comprise IC,Modules,Potentiometer,IC Socket,Relay,Connector.Our parts cover such applications as commercial,industrial, and automotives areas.

We are looking forward to setting up business relationship with you and hope to provide you with the best service and solution. Let us make a better world for our industry!



## Contact us

Tel: +86-755-8981 8866 Fax: +86-755-8427 6832

Email & Skype: info@chipsmall.com Web: www.chipsmall.com

Address: A1208, Overseas Decoration Building, #122 Zhenhua RD., Futian, Shenzhen, China



## 10-Function Remote Controller

### Features

- The PT8A992AP works as the encoder and the PT8A993AP works as the decoder
- 11 output pins, 4 for forward, backward, left and right functions, and 7 functional keys
- Operation power supply: 3.0V to 5.5V
- Auto power-off if no key pressed (PT8A992A)
- Low operating current
- On-chip oscillator with an external resistor
- On-chip receiving amplifiers
- Few external components needed

### Description

The PT8A992A/993A is a pair of CMOS LSIs designed for remote controlled toy car application. They have 11 control keys for controlling the corresponding motion (i.e. forward, backward, left, right and 7 other functions) of the remote controlled car.

### Pin Configuration

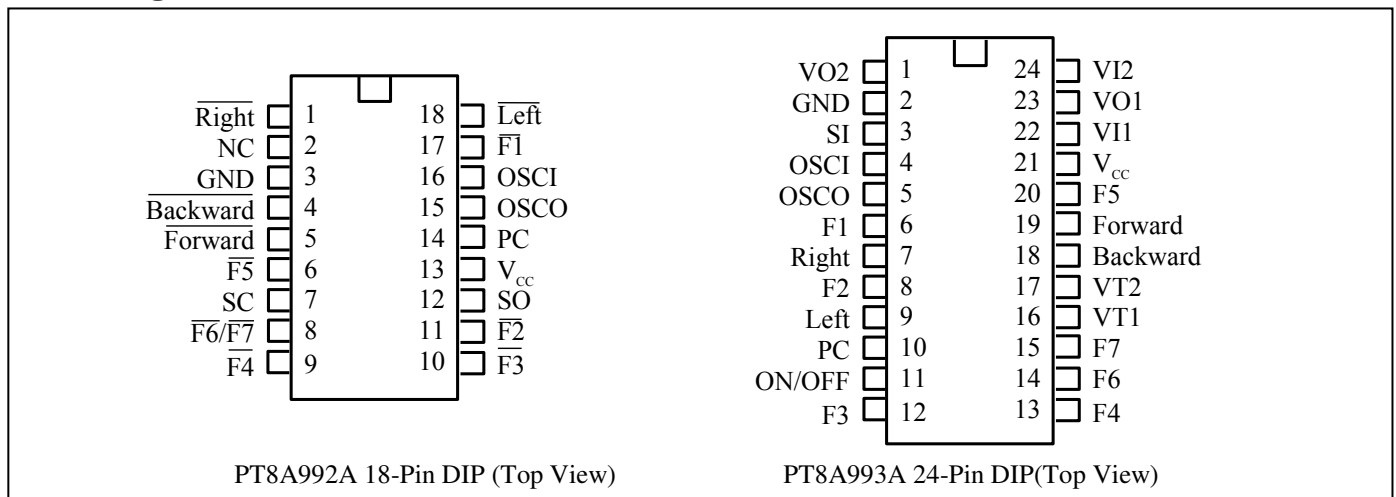

### Pin Description

#### Pin description for PT8A992A

Pin No	Pin Name	Type	Description
1	Right	I	The rightward function selected if this pin connected to GND
2	NC	-	No connection
3	GND	GND	Ground
4	Backward	I	Backward function selected if this pin connected to GND
5	Forward	I	Forward function selected if this pin connected to GND
6	F5	I	Function 5 select if this pin connected to GND
7	SC	O	Output pin of the encoding signal with carrier frequency
8	F6/F7	I	Connect to GND to toggle between F6 and F7 of PT8A993A when working with PT8A993A
9	F4	I	Function 4 selected if connected to GND
10	F3	I	Function 3 selected if connected to GND
11	F2	I	Function 2 selected if connected to GND
12	SO	O	Output pin of the encoding signal without carrier frequency
13	Vcc	P	Power supply
14	PC	O	Power control output pin
15	OSCO	O	Oscillator output pin
16	OSCI	I	Oscillator input pin
17	F1	I	Function 1 selected if connected to GND
18	Left	I	Leftward function selected if this pin connected to GND

**Pin description for PT8A993A**

Pin No	Pin Name	Type	Description
1, 23	VO1, VO2	O	Output pins of inverter 1 and 2 for Signal amplifier
2	GND	GND	Ground
3	SI	I	Input pin for encoded signal
4	OSCI	I	Oscillator input pin
5	OSCO	O	Oscillator output pin
6	F1	O	F1 function output pin
7	Right	O	Rightward output pin
8	F2	O	F2 function output pin
9	Left	O	Leftward output pin
10	PC	O	Power control pin
11	ON/OFF	I	ON/OFF pin
12	F3	O	F3 function output pin
13	F4	O	F4 function output pin
14	F6	O	F6 function output pin
15	F7	O	F7 function output pin
16	VT1	I	Auto shut off input pin: if the voltage on this pin keeps higher than 0.095V <sub>cc</sub> for 3 seconds, all outputs will be shut off automatically.
17	VT2	I	Auto shut off input pin: if the voltage on this pin keeps higher than 0.095V <sub>cc</sub> for 3 seconds, all outputs will be shut off automatically.
18	Backward	O	Backward output pin
19	Forward	O	Forward output pin
20	F5	O	F5 function output pin
21	Vcc	P	Power supply
22, 24	VI1, VI2	I	Input pins of invertors 1 and 2 for signal amplifier

**Block Diagram**

Block diagram for PT8A992A

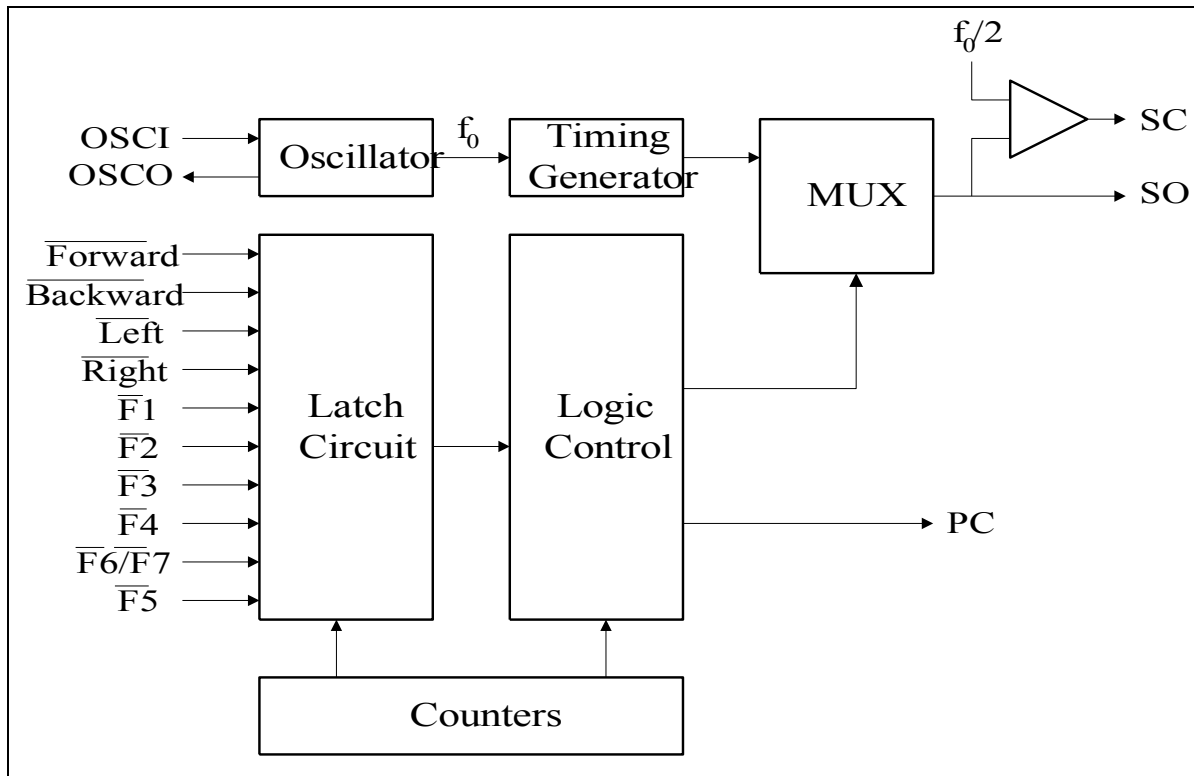

Block diagram for PT8A993A

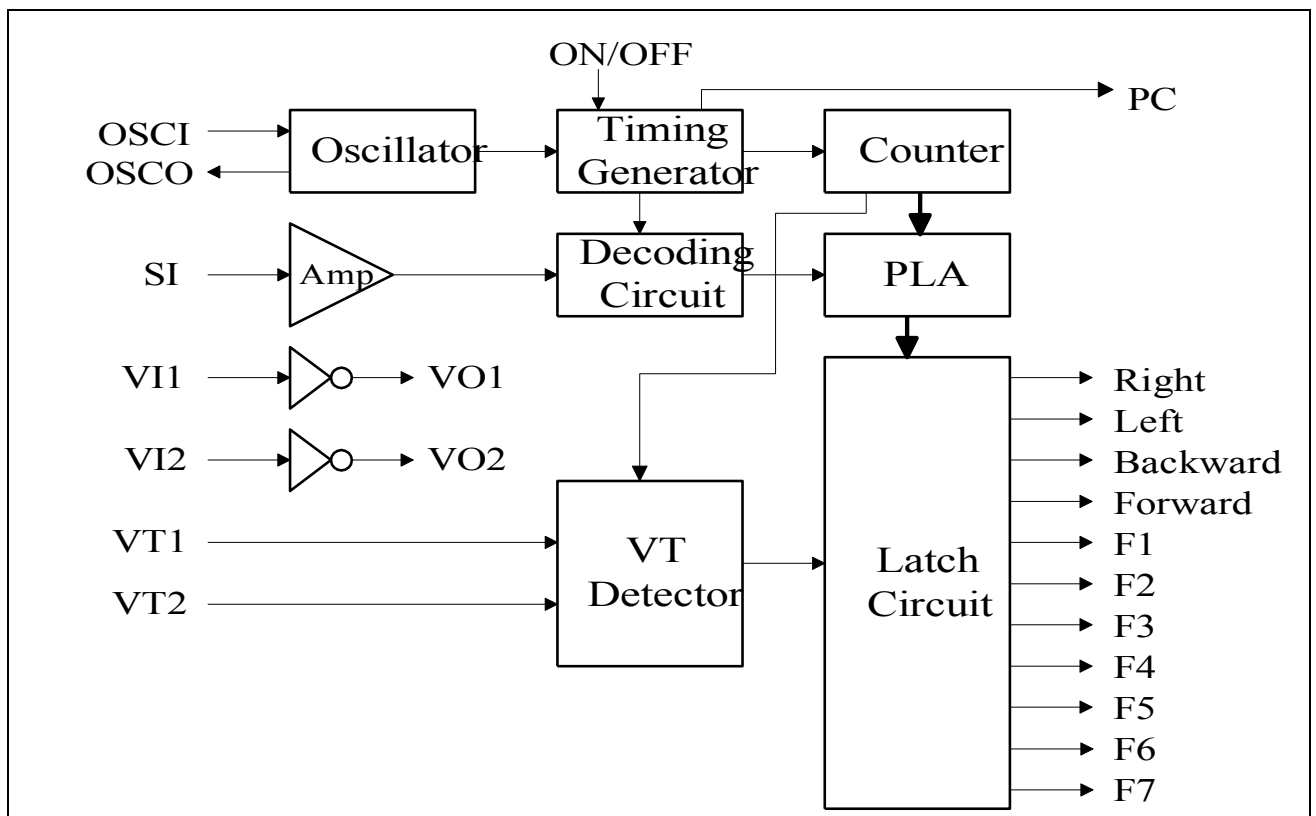

## Maximum Ratings

Storage Temperature.....	-25°C to +85°C
Ambient Temperature with Power Applied.....	0°C to +70°C
Supply Voltage to Ground Potential (Inputs & V <sub>cc</sub> Only).....	-0.5 to +5.5V
Supply Voltage to Ground Potential (Outputs & D/O Only).....	-0.5 to +5.5V
DC Input Voltage.....	-0.5 to +5.5V
DC Output Current.....	20mA
Power Dissipation.....	500mW

**Note:**

Stresses greater than those listed under MAXIMUM RATINGS may cause permanent damage to the device. This is a stress rating only and functional operation of the device at these or any other conditions above those indicated in the operational sections of this specification is not implied. Exposure to absolute maximum rating conditions for extended periods may affect reliability.

## Recommended Operation Conditions

Sym	Description	Min	Typ	Max	Unit
V <sub>CC</sub>	Supply Voltage	3	4	5	V
V <sub>IH</sub>	Input HIGH Voltage	0.7V <sub>CC</sub>	4	-	V
V <sub>IL</sub>	Input LOW Voltage	-	0	0.3V <sub>CC</sub>	V
FOSC	Oscillator frequency	109	128	146	kHz
T <sub>A</sub>	Operation temperature	0	-	70	°C

## DC Electrical Characteristics

PT8A992A (Unless otherwise noted, V<sub>CC</sub> = 4.0V, T<sub>A</sub> = 0 ~ 70°C)

Sym	Description	Test conditions	Min	Typ	Max	Unit
I <sub>STB</sub>	Stand by current	T <sub>A</sub> = 70°C, Off state	-	-	2	μA
I <sub>CC</sub>	Supply Current	Output Unload	-	-	300	μA
I <sub>OH</sub>	Output HIGH Current - PC and SO Pins	V <sub>OH</sub> =3.5V, T <sub>A</sub> = 25°C	-1	-2	-	mA
	Output HIGH Current - SC Pin		-3	-4	-	mA
	Output HIGH Current - OSCO Pin		-400	-	-	μA
I <sub>OL</sub>	Output LOW Current - SC, PC and SO Pins	V <sub>OL</sub> =0.5V, T <sub>A</sub> = 25°C	1	-	-	mA
	Output LOW Current - OSCO Pin		400	-	-	μA
I <sub>IH</sub>	Input HIGH Current - Forward, Backward, Left, Right, F1, F2, F3, F4, F5, F6/F7, OSCI Pins	V <sub>CC</sub> =5.5V, V <sub>IH</sub> =V <sub>CC</sub> , T <sub>A</sub> = 25°C	-	-	10	μA
I <sub>IL</sub>	Input HIGH Current - Forward, Backward, Left, Right, F1, F2, F3, F4, F5, F6/F7 Pins	V <sub>CC</sub> =5.5V, V <sub>IL</sub> =0V, T <sub>A</sub> = 25°C	-15	-25	-100	μA
	Input LOW Current - OSCI Pin		-	-	-10	μA

PT8A993A (Unless otherwise noted,  $V_{CC} = 4.0V$ ,  $T_A = 0 \sim 70^\circ C$ )

Sym	Description	Test conditions	Min	Typ	Max	Unit
$I_{STB}$	Stand by current	$T_A = 70^\circ C$ , Off state	-	3	20	$\mu A$
$I_{CC}$	Supply Current	Output Unload	-	-	700	$\mu A$
$I_{OH}$	Output HIGH Current - VO1, VO2 and OSCO Pins	$V_{OH} = 3.5V$ , $T_A = 25^\circ C$	-300	-	-	$\mu A$
	Output HIGH Current - Forward, Backward, Left and Right Pins		-2	-5	-	mA
	Output HIGH Current - F1, F2, F3 F4, F5 and F6 Pins		-2	-5	-	mA
	Output HIGH Current - PC Pin		-2	-3	-	mA
$I_{OL}$	Output LOW Current - VO1, VO2 and OSCO Pins	$V_{OL} = 0.5V$ , $T_A = 25^\circ C$	150	-	-	$\mu A$
	Output LOW Current - Forward, Backward, Left and Right Pins		1	3	-	mA
	Output LOW Current - F1, F2, F3, F4, F5 and F6 Pins		1	3	-	mA
	Output LOW Current - PC Pin		2	-	-	mA
$I_{IH}$	Input HIGH Current - VT1 and VT2 Pins	$V_I = V_{CC}$ , $T_A = 25^\circ C$	20	30	100	$\mu A$
	Input HIGH Current - SI, VI1, VI2, ON/OFF and OSCI Pins		-	-	10	$\mu A$
$I_{IL}$	Input LOW Current - SI, VI1, VI2, VT1, VT2 and OSCI Pins	$V_I = 0V$ , $T_A = 25^\circ C$	-	-	-10	$\mu A$
	Input LOW Current - ON/OFF Pin		-20	-30	-100	$\mu A$
VT	Over Current Limit VT1 and VT2 Pins	Forward is high	0.35	-	0.45	V

## AC Electrical Characteristics

PT8A992A (Unless otherwise noted,  $V_{CC} = 4.0$ ,  $T_A = 0 \sim 70^\circ C$ )

Sym	Description	Test conditions	Min	Typ	Max	Unit
$f_{OSC}^{(Note)}$	Oscillator Frequency	$R_f = 180k\Omega$ , $T_A = 25^\circ C$	109	128	146	kHz
$t_{FUN}$	Period Function Code	$f_{OSC} = 128kHz$ , $T_A = 25^\circ C$	1.7	2	2.3	ms
$f_{OSC}$	Carrier Frequency	$f_{OSC} = 128kHz$ , $T_A = 25^\circ C$	-	64	-	kHz

PT8A993A (Unless otherwise noted,  $V_{CC} = 4.0$ ,  $T_A = 0 \sim 70^\circ C$ )

Sym	Description	Test conditions	Min	Typ	Max	Unit
$f_{OSC}^{(Note)}$	Oscillator Frequency	$R_f = 180k\Omega$ , $T_A = 25^\circ C$	109	128	146	kHz
$t_{FUN}$	Period Function Code	$f_{OSC} = 128kHz$ , $T_A = 25^\circ C$	1.7	2	2.3	ms

Note: The frequency of standard samples is tested on standard testing-board.

### Typical Application Circuit Typical Application Circuit for PT8A992A

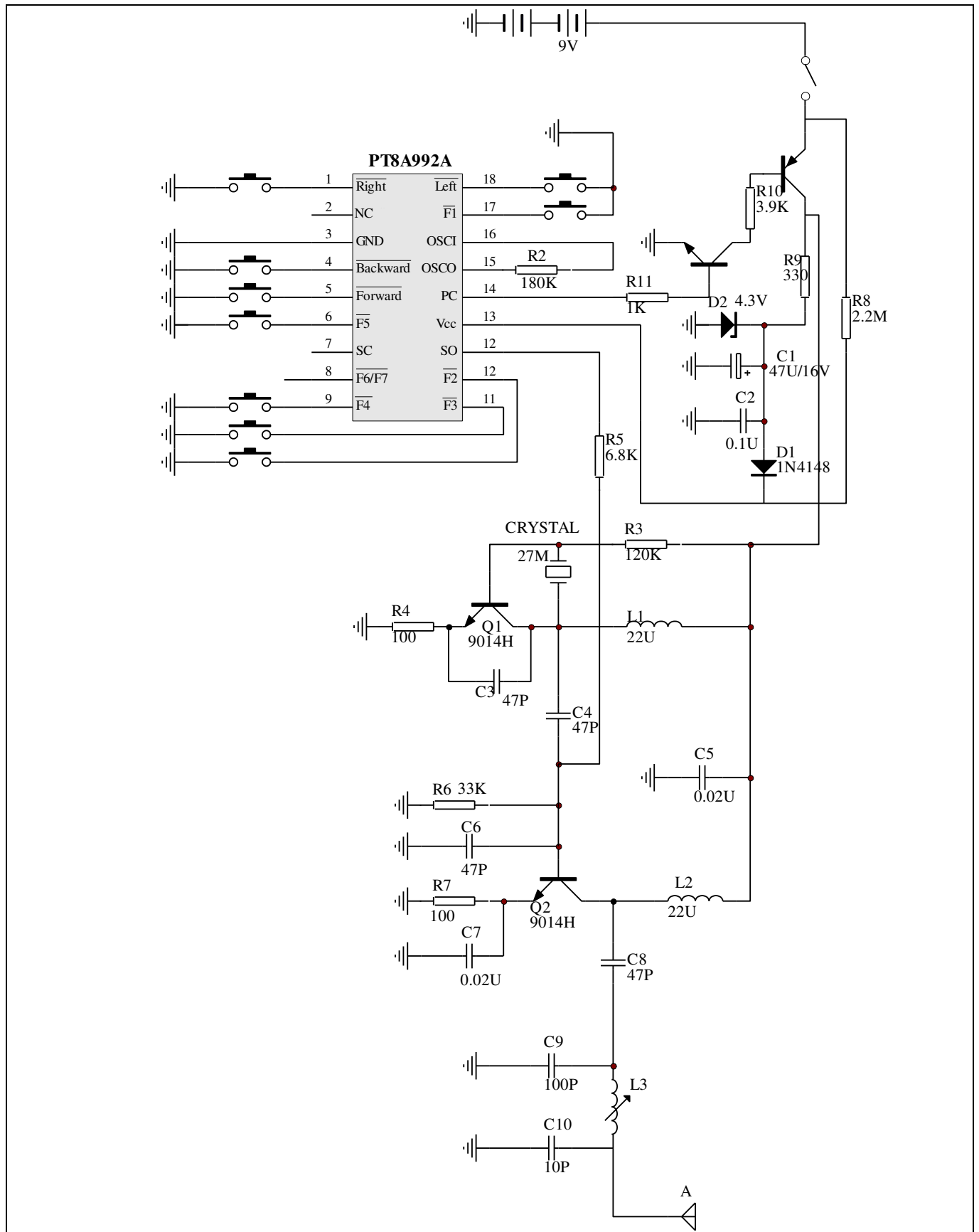



### Typical Application Circuit for PT8A993A

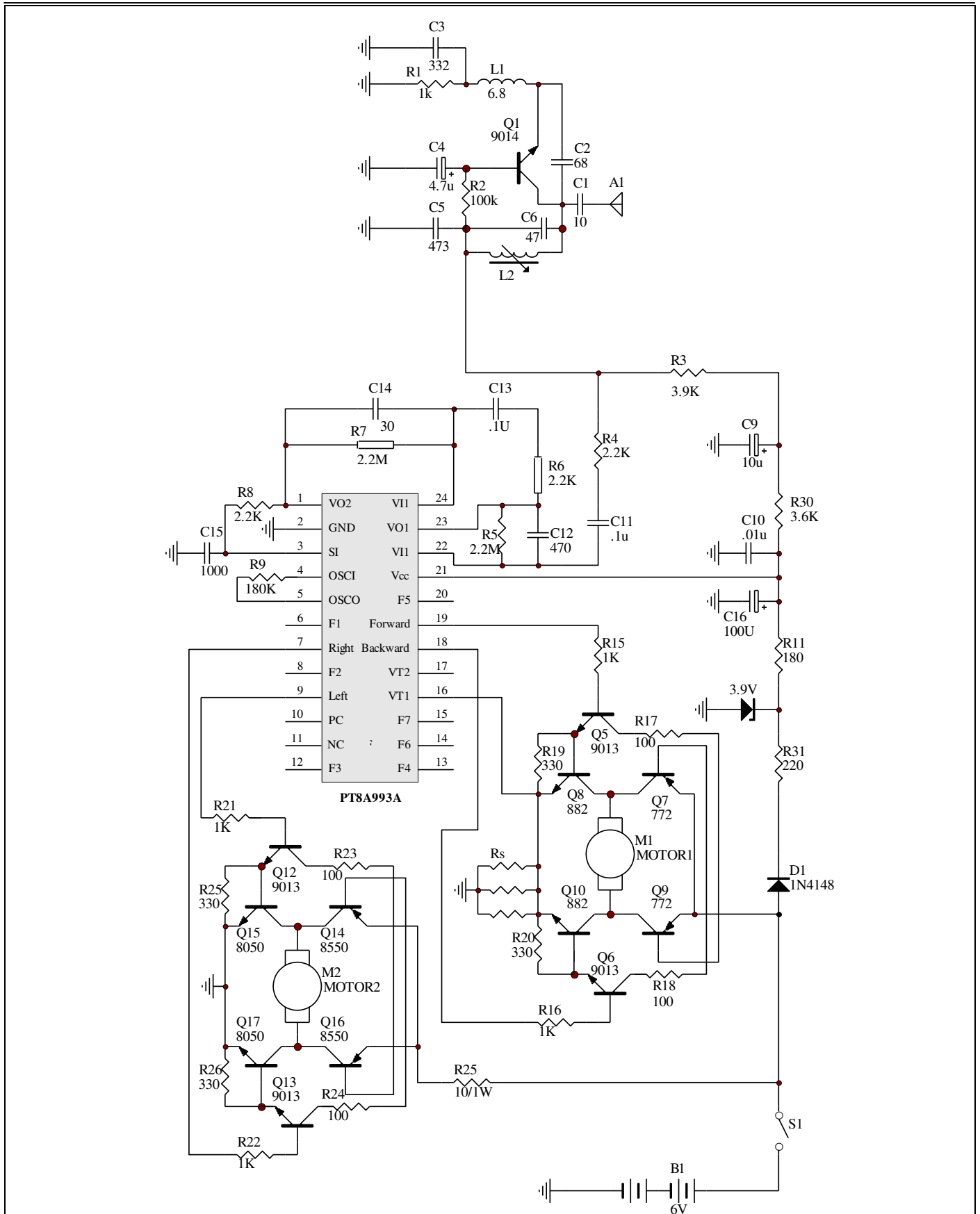

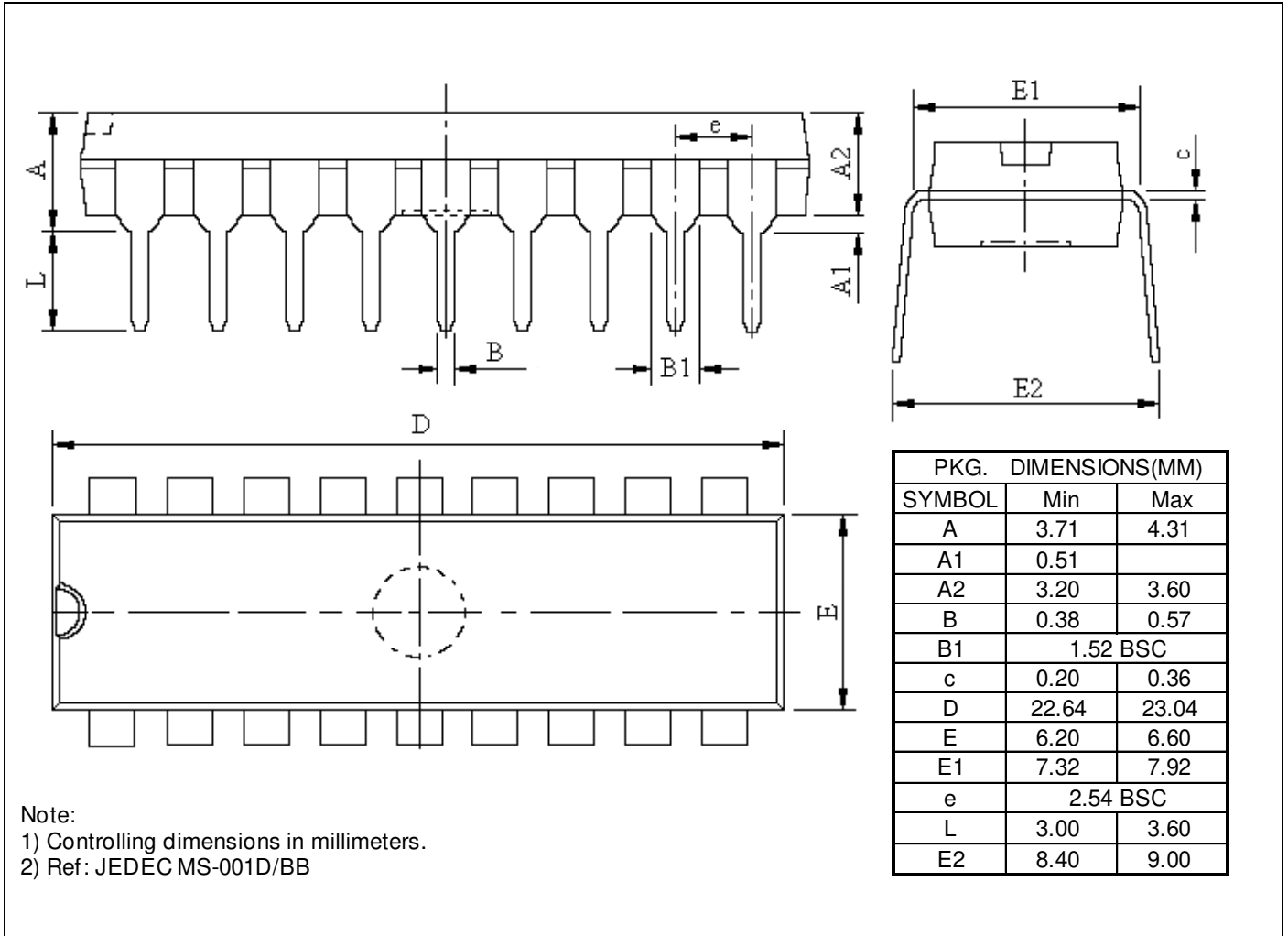

**Mechanical Information**
**DIP-18**

DIP-24

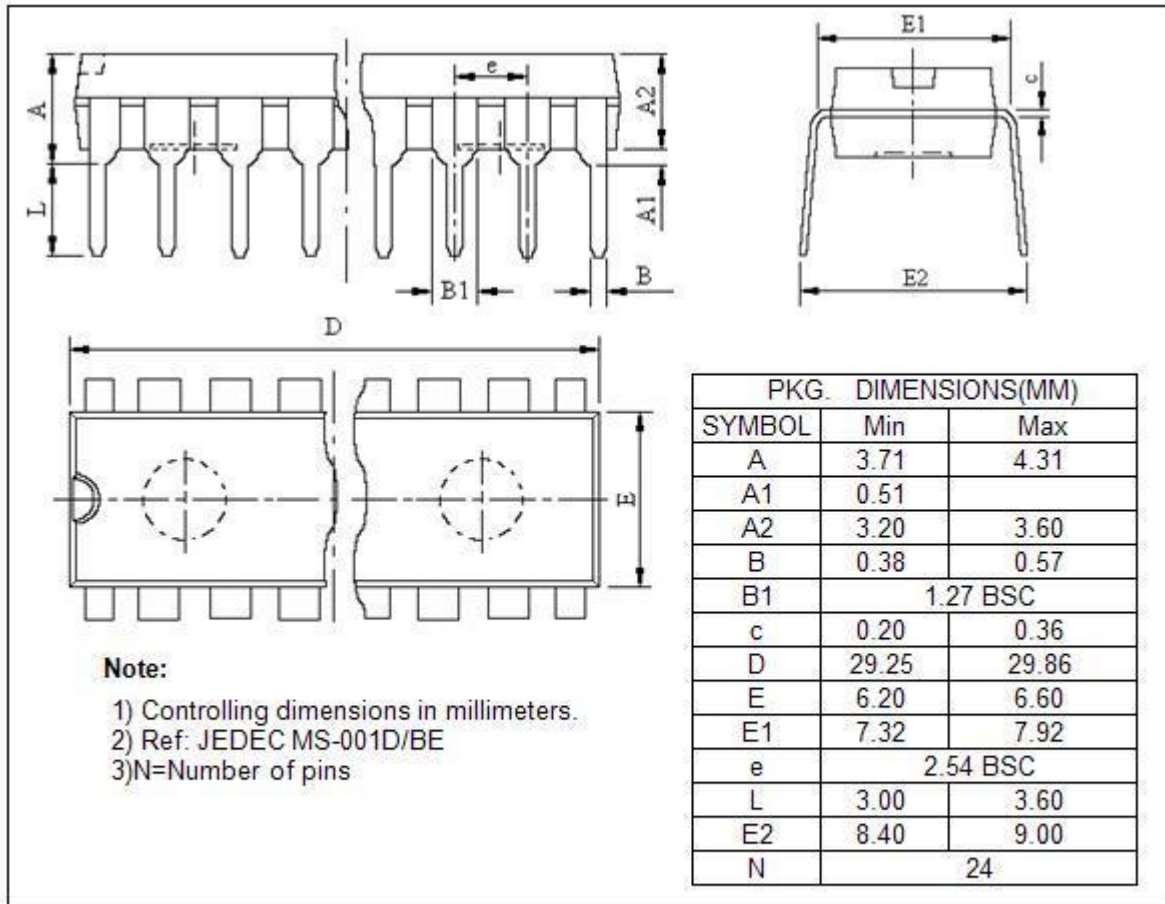

### Ordering Information

Part No.	Package Code	Package
PT8A992APE	P	Lead free DIP-18
PT8A993APE	P	Lead free DIP-24

**Note:**

- E = Pb-free
- Adding X Suffix= Tape/Reel

Pericom Semiconductor Corporation • 1-800-435-2336 • [www.pericom.com](http://www.pericom.com)

Pericom Technology Incorporation reserves the right to make changes to its products or specifications at any time, without notice, in order to improve design or performance and to supply the best possible product. Pericom Technology does not assume any responsibility for use of any circuitry described other than the circuitry embodied in Pericom Technology product. The company makes no representations that circuitry described herein is free from patent infringement or other rights, of Pericom.