



Chipsmall Limited consists of a professional team with an average of over 10 year of expertise in the distribution of electronic components. Based in Hongkong, we have already established firm and mutual-benefit business relationships with customers from,Europe,America and south Asia,supplying obsolete and hard-to-find components to meet their specific needs.

With the principle of “Quality Parts,Customers Priority,Honest Operation,and Considerate Service”,our business mainly focus on the distribution of electronic components. Line cards we deal with include Microchip,ALPS,ROHM,Xilinx,Pulse,ON,Everlight and Freescale. Main products comprise IC,Modules,Potentiometer,IC Socket,Relay,Connector.Our parts cover such applications as commercial,industrial, and automotives areas.

We are looking forward to setting up business relationship with you and hope to provide you with the best service and solution. Let us make a better world for our industry!



## Contact us

Tel: +86-755-8981 8866 Fax: +86-755-8427 6832

Email & Skype: info@chipsmall.com Web: www.chipsmall.com

Address: A1208, Overseas Decoration Building, #122 Zhenhua RD., Futian, Shenzhen, China



## TWIN Vertical SMD PTC Thermistors For Telecom Overload Protection

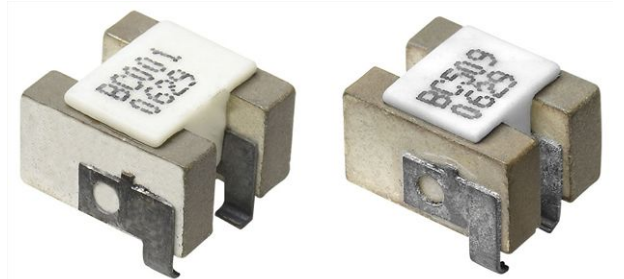

QUICK REFERENCE DATA		
PARAMETER	VALUE	UNIT
Resistance value at 25 °C	10 to 50	Ω
Switching temperature	105 to 130	°C
Maximum voltage (RMS)	240	V <sub>RMS</sub>
Maximum overload current	2.5 to 8.0	A
Operating temperature range at V <sub>max.</sub>	-40 to 85	°C
Maximum trip time at 1 A	1.2 to 4.0	s
Weight	~ 1.3	g

### DESCRIPTION

The component consists of two high performance PTC ceramics mounted together on an alumina spacer cover and with 4 lead (Pb)-free tin plated contacts. The terminations are joined to the Ag plated ceramics by a high melting solder.

### MARKING

- All TWIN Vertical SMD PTC's are marked with the last 3-digits of the type number (BCxxx) and a date code (YYWW)

### FEATURES

- Very small footprint, allowing to increase the number of lines per PCB
- Matched pairs in one component, significantly reducing the assembly time
- Narrow tracking between the 2 PTC's over a wide temperature range (matching at 85 °C: ≤ 2 x matching at 25 °C)
- Limited height and weight, used on high speed pick-and-place circuit assembly
- Flat pick-up ceramic area for easy placement
- Small ceramics for faster response time
- Thermal coupled PTC's for enhanced protection
- Small and large pitch available
- Compliant with the enhanced level requirements of ITU - K20-21-45 edition 2003
- Suitable for lead (Pb)-bearing and lead (Pb)-free reflow soldering
- Material categorization: For definitions of compliance please see [www.vishay.com/doc?99912](http://www.vishay.com/doc?99912)

**RoHS**  
COMPLIANT

### APPLICATIONS

Over-temperature/over-load protection:

- Telecom
  - Telecommunications infrastructure
  - PABX
  - Set-top Box (S.B.)

### MOUNTING

A flat pick-up area of 30 mm<sup>2</sup> and low weight allows for fast placement. No excessive solder paste should be used as no solder or flux can reach the ceramic body during reflow soldering. Not suitable for bismuth containing solder.

Typical soldering

235 °C, duration: 5 s (Lead (Pb)-bearing)

245 °C, duration: 5 s (Lead (Pb)-free)

Resistance to soldering heat

260 °C, duration: 10 s max.

ELECTRICAL DATA									
R <sub>25</sub> ± 20 % (Ω)	MATCHING (Ω)	V <sub>max.</sub> (V <sub>RMS</sub> )	I <sub>nt</sub> at			I <sub>t</sub> (mA)	MAX. TRIP-TIME at 1 A (s)	I <sub>max.</sub> at V <sub>max.</sub> (A)	I <sub>res.</sub> (2 PIECES POWERED) at V <sub>max.</sub> (mA)
			25 °C (mA)	70 °C (mA)	85 °C (mA)				
10	0.5	240	140	85	55	300	4.0	4.0	12.0
20	0.5	240	90	60	40	200	2.0	8.0	12.0
25	0.5	240	100	60	40	200	2.0	4.0	12.0
35	1.0	240	100	60	40	200	1.5	4.0	12.0
50	1.0	240	90	50	35	190	1.2	2.5	12.0

### Note

- All data is measured at 25 °C unless otherwise specified

ORDERING INFORMATION		
$R_{25} \pm 20\%$ ( $\Omega$ )	SAP CODING	
	SMALL PITCH	LARGE PITCH
10	PTCTT95R100GTE	PTCTT95R100GTELAR
20	PTCTT95R200GTE	PTCTT95R200GTELAR
25	PTCTT95R250GTE	PTCTT95R250GTELAR
35	PTCTT95R350GTE	PTCTT95R350GTELAR
50	PTCTT95R500GTE	PTCTT95R500GTELAR

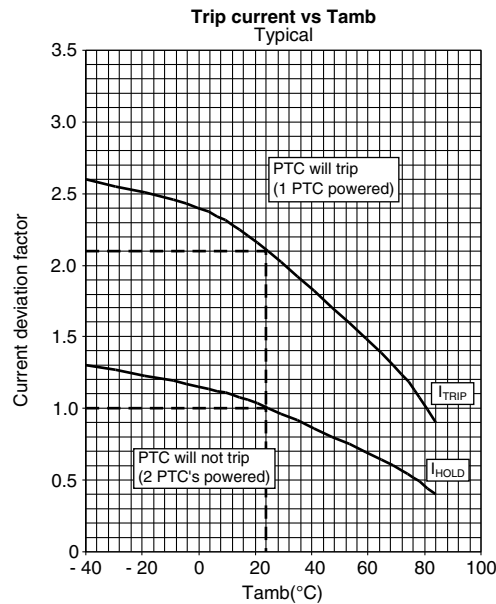
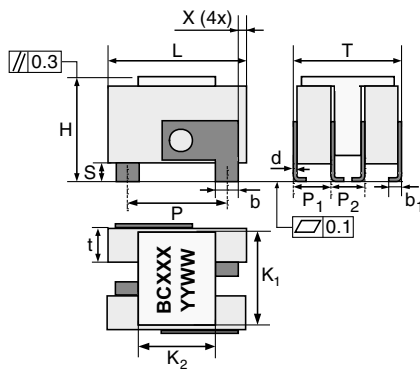
**ELECTRICAL CHARACTERISTICS**

**PTC OUTLINES**

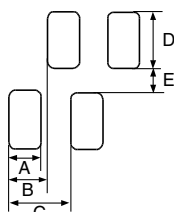
**DIMENSIONS** in millimeters

	SMALL PITCH	LARGE PITCH
L	9.0 ± 0.1	9.0 ± 0.1
T	7.2 ± 0.25	8.4 ± 0.25
H	6.9 ± 0.25	6.9 ± 0.25
b	1.5 ± 0.1	1.5 ± 0.1
b <sub>1</sub>	0.9 ± 0.15	0.9 ± 0.15
S	1.25 ± 0.15	1.25 ± 0.15
d	0.22 ± 0.025	0.22 ± 0.025
t	2.3 ± 0.1	2.3 ± 0.1
P	6.5 ± 0.5	6.5 ± 0.5
P <sub>1</sub>	2.55 ± 0.15	2.55 ± 0.15
P <sub>2</sub>	2.2 ± 0.1	3.45 ± 0.15
X	0.5 ± 0.2	0.5 ± 0.2
K <sub>1</sub>	6.0 ± 0.5	7.2 ± 0.5
K <sub>2</sub>	5.0 ± 0.5	5.0 ± 0.5

**FOOTPRINT**

**RECOMMENDED FOOTPRINT** in millimeters

	SMALL PITCH	LARGE PITCH
A	2.0	2.0
B	2.4	2.4
C	3.8	5.0
D	3.8	4.0
E	2.7	1.4

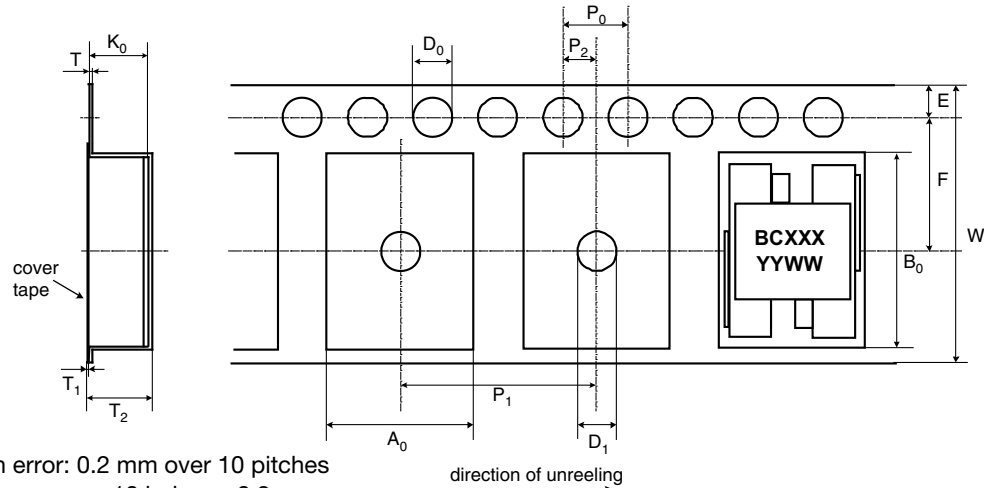

**PACKAGING**
**Tape specifications**

All tape and reel specifications are in accordance with IEC 60286-3. Carrier tape material is non-conductive polystyrene or polycarbonate.

**Blister tape**

Cumulative pitch error: 0.2 mm over 10 pitches

Cumulative tolerance over 10 holes:  $\pm 0.2$  mm

DIMENSIONS OF BLISTER TAPE in millimeters					
	SMALL PITCH	LARGE PITCH		SMALL PITCH	LARGE PITCH
$A_0$	$7.2 \pm 0.1$	$8.4 \pm 0.1$	$D_1$	$1.5 + 0.1$	$1.5 + 0.1$
$B_0$	$9.3 \pm 0.1$	$9.3 \pm 0.1$	$P_0$	$4.0 \pm 0.1$	$4.0 \pm 0.1$
$K_0$	$7.2 \pm 0.1$	$7.2 \pm 0.1$	$P_1$	$12.0 \pm 0.1$	$12.0 \pm 0.1$
$W$	$16.0 \pm 0.3$	$16.0 \pm 0.3$	$P_2$	$2.0 \pm 0.1$	$2.0 \pm 0.1$
$E$	$1.75 \pm 0.1$	$1.75 \pm 0.1$	$T$	$0.5 \pm 0.05$	$0.5 \pm 0.05$
$F$	$7.5 \pm 0.1$	$7.5 \pm 0.1$	$T_1$	0.05	0.05
$D_0$	$1.5 + 0.1$	$1.5 + 0.1$	$T_2$	7.8 max.	7.8 max.

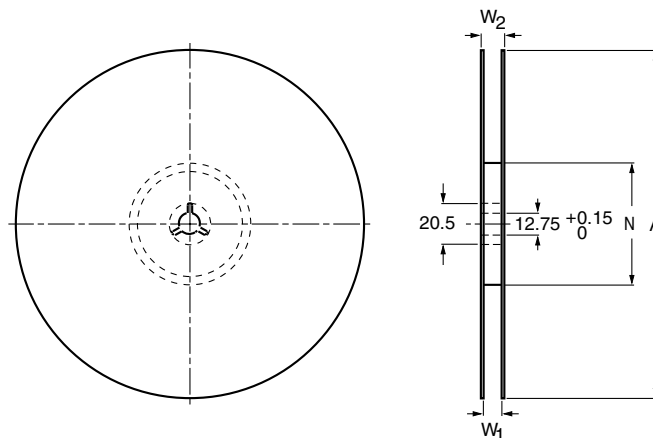
**REEL SPECIFICATIONS in millimeters**
**Reel**

REEL DIMENSIONS in millimeters					
UNITS PER REEL	TAPE WIDTH	A	N	$W_1$	$W_2$ MAX.
1000	16	380	64	16.4	20.4

**Note**

- Reels are packed in sealed plastic bags for protection against high humidity and corrosive atmospheres

**SOLDERING CONDITIONS**

This SMD thermistor is only suitable for reflow soldering, in accordance with JEDEC J-STD-020. Soldering processes which can be used are reflow (infrared and convection heating) and vapour phase. The maximum temperature of 260 °C during 10 s should not be exceeded and no liquid flux should be allowed to reach the ceramic body.

Typical examples of soldering processes that will provide reliable joints without damage, are shown below.

Reflow soldering

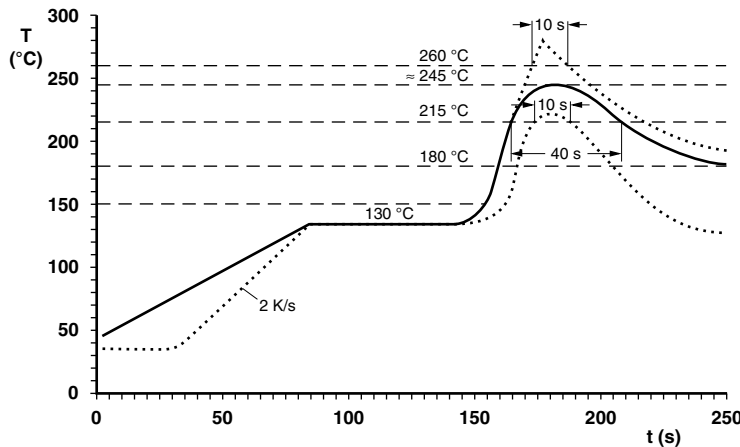

Typical values (solid line)  
Process limits (dotted lines)

Vapour phase soldering

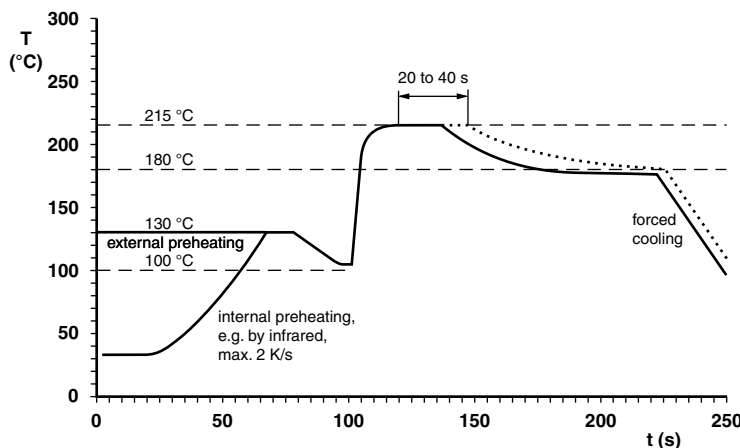

Typical values (solid line)  
Process limits (dotted line)

**HANDLING PRECAUTIONS**

Because of the nature of PTC ceramic material the component should not be touched with bare hands, as the residue of perspiration can influence component behaviour at high temperatures.

Handling forces applied to the component should be limited to 5 N in any condition.



## **Disclaimer**

ALL PRODUCT, PRODUCT SPECIFICATIONS AND DATA ARE SUBJECT TO CHANGE WITHOUT NOTICE TO IMPROVE RELIABILITY, FUNCTION OR DESIGN OR OTHERWISE.

Vishay Intertechnology, Inc., its affiliates, agents, and employees, and all persons acting on its or their behalf (collectively, "Vishay"), disclaim any and all liability for any errors, inaccuracies or incompleteness contained in any datasheet or in any other disclosure relating to any product.

Vishay makes no warranty, representation or guarantee regarding the suitability of the products for any particular purpose or the continuing production of any product. To the maximum extent permitted by applicable law, Vishay disclaims (i) any and all liability arising out of the application or use of any product, (ii) any and all liability, including without limitation special, consequential or incidental damages, and (iii) any and all implied warranties, including warranties of fitness for particular purpose, non-infringement and merchantability.

Statements regarding the suitability of products for certain types of applications are based on Vishay's knowledge of typical requirements that are often placed on Vishay products in generic applications. Such statements are not binding statements about the suitability of products for a particular application. It is the customer's responsibility to validate that a particular product with the properties described in the product specification is suitable for use in a particular application. Parameters provided in datasheets and / or specifications may vary in different applications and performance may vary over time. All operating parameters, including typical parameters, must be validated for each customer application by the customer's technical experts. Product specifications do not expand or otherwise modify Vishay's terms and conditions of purchase, including but not limited to the warranty expressed therein.

Except as expressly indicated in writing, Vishay products are not designed for use in medical, life-saving, or life-sustaining applications or for any other application in which the failure of the Vishay product could result in personal injury or death. Customers using or selling Vishay products not expressly indicated for use in such applications do so at their own risk. Please contact authorized Vishay personnel to obtain written terms and conditions regarding products designed for such applications.

No license, express or implied, by estoppel or otherwise, to any intellectual property rights is granted by this document or by any conduct of Vishay. Product names and markings noted herein may be trademarks of their respective owners.