



Chipsmall Limited consists of a professional team with an average of over 10 year of expertise in the distribution of electronic components. Based in Hongkong, we have already established firm and mutual-benefit business relationships with customers from,Europe,America and south Asia,supplying obsolete and hard-to-find components to meet their specific needs.

With the principle of “Quality Parts,Customers Priority,Honest Operation,and Considerate Service”,our business mainly focus on the distribution of electronic components. Line cards we deal with include Microchip,ALPS,ROHM,Xilinx,Pulse,ON,Everlight and Freescale. Main products comprise IC,Modules,Potentiometer,IC Socket,Relay,Connector.Our parts cover such applications as commercial,industrial, and automotives areas.

We are looking forward to setting up business relationship with you and hope to provide you with the best service and solution. Let us make a better world for our industry!



## Contact us

Tel: +86-755-8981 8866 Fax: +86-755-8427 6832

Email & Skype: info@chipsmall.com Web: www.chipsmall.com

Address: A1208, Overseas Decoration Building, #122 Zhenhua RD., Futian, Shenzhen, China



# PTFB210801FA

## Thermally-Enhanced High Power RF LDMOS FET 80 W, 28 V, 2110 – 2170 MHz

### Description

The PTFB210801FA LDMOS FET is designed for use in multi-standard cellular power amplifier applications in the 2110 to 2170 MHz frequency band. Features include input and output matching, high gain and thermally-enhanced packages with earless flanges. Manufactured with Wolfspeed's advanced LDMOS process, this device provides excellent thermal performance and superior reliability.

PTFB210801FA  
Package H-37265-2

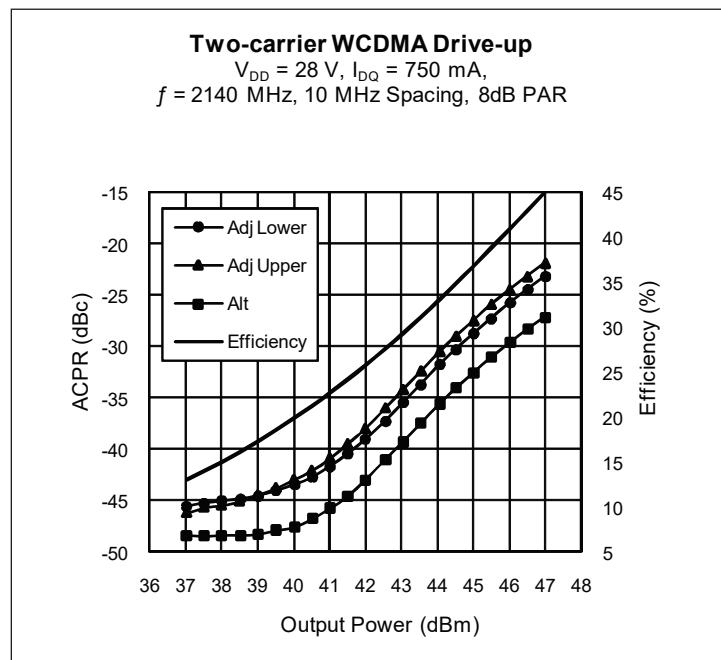

### Features

- Broadband internal matching
- Typical single-carrier WCDMA performance at 2170 MHz, 28 V
  - Average output power = 25 W
  - Linear Gain = 18.5 dB
  - Efficiency = 32.5%
  - Adjacent channel power = -37 dBc
- Typical CW performance, 2170 MHz, 28 V
  - Output power at  $P_{1dB}$  = 80 W
  - Efficiency = 55%
- Integrated ESD protection
- Capable of handling 10:1 VSWR @ 28 V, 80 W (CW) output power
- Pb-free and RoHS compliant

### RF Characteristics

#### Two-carrier WCDMA Measurements (tested in Wolfspeed test fixture)

$V_{DD} = 28\text{ V}$ ,  $I_{DQ} = 750\text{ mA}$ ,  $P_{OUT} = 20\text{ W}$  average,  $f_1 = 2160\text{ MHz}$ ,  $f_2 = 2170\text{ MHz}$ , 3GPP signal, channel bandwidth = 3.84 MHz, peak/average = 8 dB @ 0.01% CCDF

Characteristic	Symbol	Min	Typ	Max	Unit
Gain	$G_{ps}$	18	18.5	—	dB
Drain Efficiency	$\eta_D$	28	31	—	%
Intermodulation Distortion	IMD	—	-30	-28	dBc

All published data at  $T_{CASE} = 25^\circ\text{C}$  unless otherwise indicated

ESD: Electrostatic discharge sensitive device—observe handling precautions!

## DC Characteristics

Characteristic	Conditions	Symbol	Min	Typ	Max	Unit
Drain-Source Breakdown Voltage	$V_{GS} = 0\text{ V}, I_{DS} = 10\text{ mA}$	$V_{(BR)DSS}$	65	—	—	V
Drain Leakage Current	$V_{DS} = 28\text{ V}, V_{GS} = 0\text{ V}$	$I_{DSS}$	—	—	1.0	$\mu\text{A}$
Drain Leakage Current	$V_{DS} = 63\text{ V}, V_{GS} = 0\text{ V}$	$I_{DSS}$	—	—	10.0	$\mu\text{A}$
On-State Resistance	$V_{GS} = 10\text{ V}, V_{DS} = 0.1\text{ V}$	$R_{DS(on)}$	—	0.05	—	$\Omega$
Operating Gate Voltage	$V_{DS} = 30\text{ V}, I_{DQ} = 750\text{ mA}$	$V_{GS}$	2.3	3.0	3.3	V
Gate Leakage Current	$V_{GS} = 10\text{ V}, V_{DS} = 0\text{ V}$	$I_{GSS}$	—	—	1.0	$\mu\text{A}$

## Maximum Ratings

Parameter	Symbol	Value	Unit
Drain-Source Voltage	$V_{DSS}$	65	V
Gate-Source Voltage	$V_{GS}$	-6 to +10	V
Junction Temperature	$T_J$	200	$^{\circ}\text{C}$
Storage Temperature Range	$T_{STG}$	-40 to +150	$^{\circ}\text{C}$
Thermal Resistance ( $T_{CASE} = 70^{\circ}\text{C}, 80\text{ W CW}$ )	$R_{\theta JC}$	0.50	$^{\circ}\text{C/W}$

## Ordering Information

Type and Version	Order Code	Package Description	Shipping
PTFB210801FA V1 R0	PTFB210801FA-V1-R0	H-37265-2, earless flange	Tape & Reel, 50 pcs
PTFB210801FA V1 R250	PTFB210801FA-V1-R250	H-37265-2, earless flange	Tape & Reel, 250 pcs

**Typical Performance** (data taken in a production test fixture)

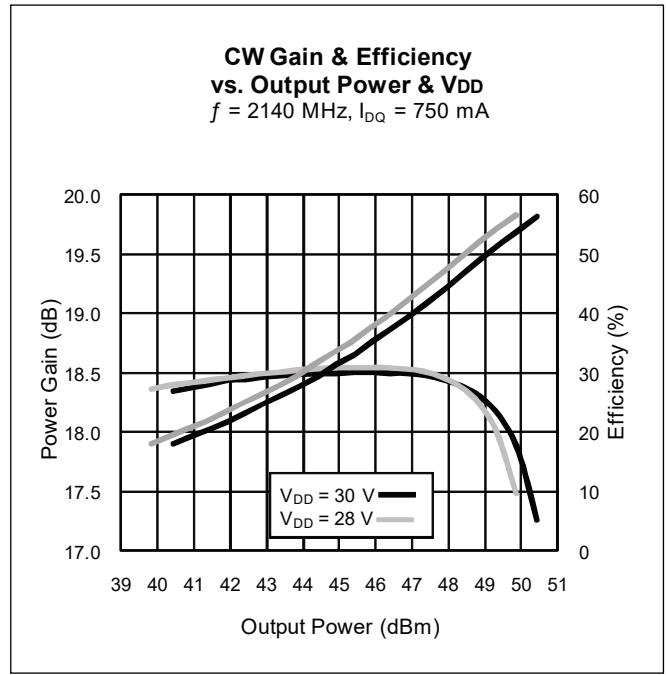
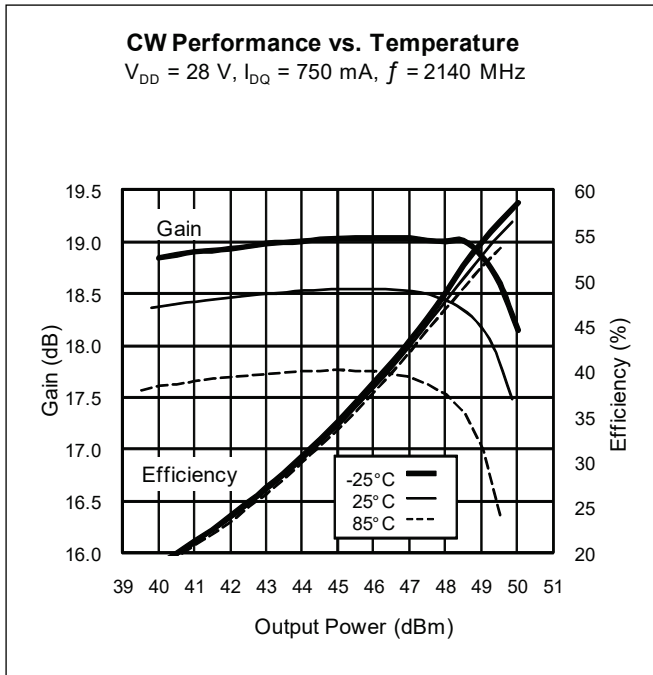
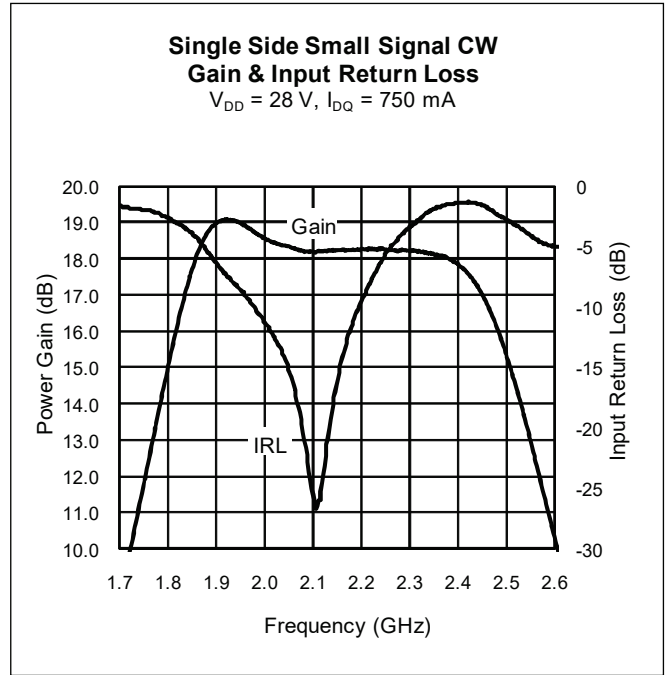
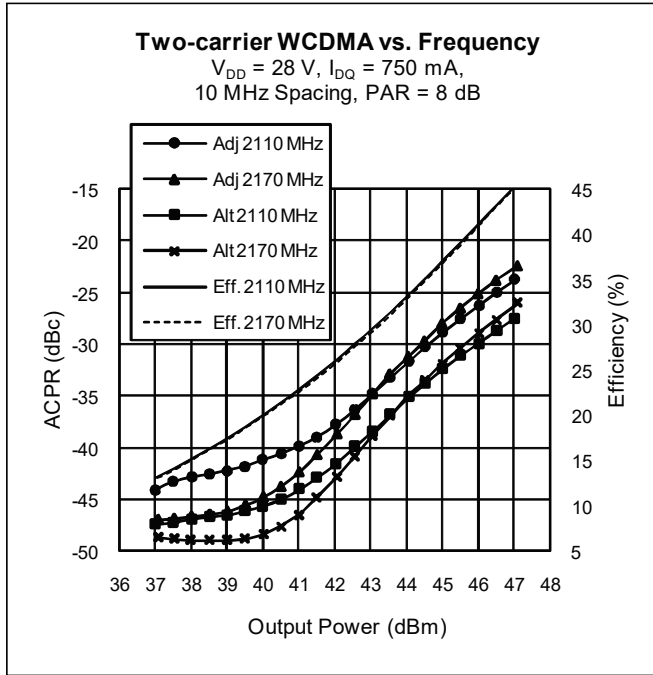



Typical Performance (cont.)

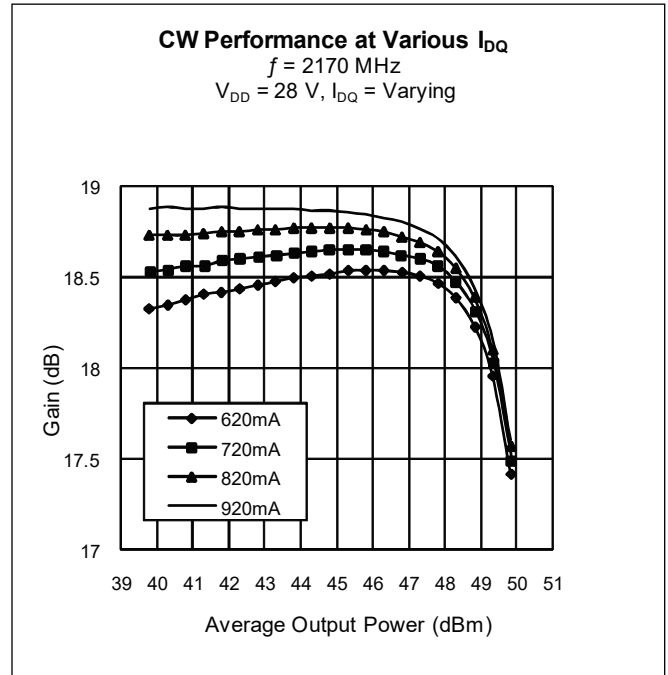
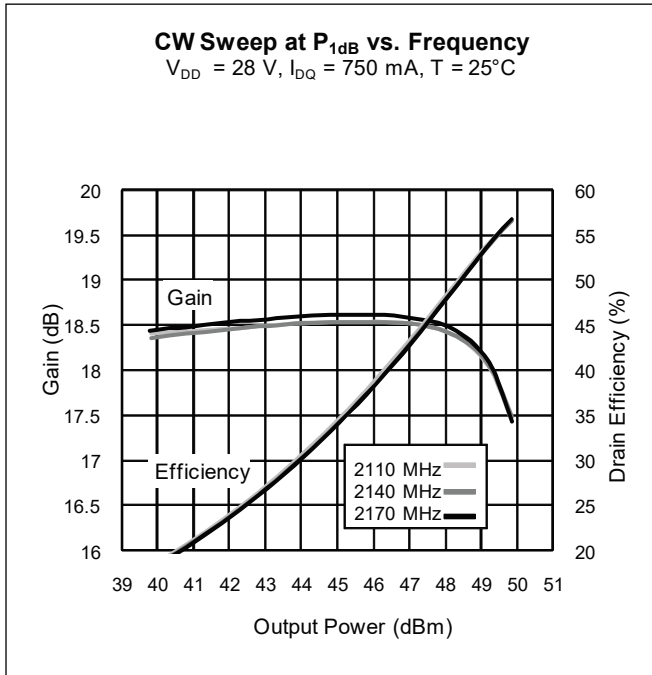

Broadband Circuit Impedance

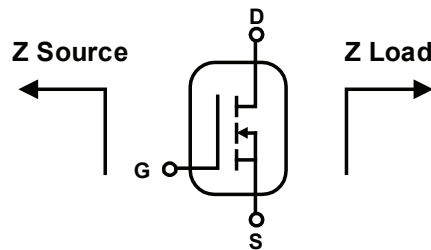

Frequency MHz	Z Source $\Omega$		Z Load $\Omega$	
	R	jX	R	jX
2110	16.3	-4.6	2.2	-4.1
2140	13.6	-4.0	2.3	-4.1
2170	11.3	-2.9	2.2	-4.4

Reference Circuit

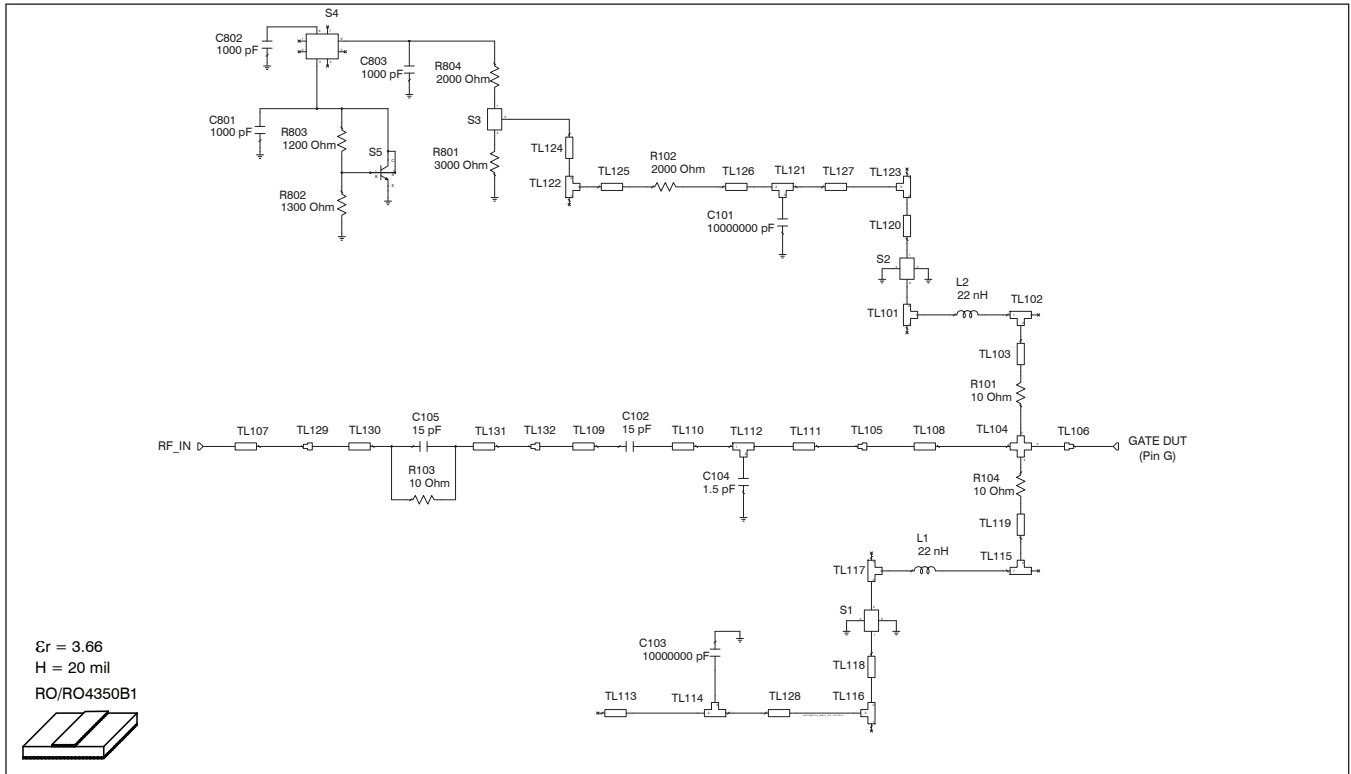

Reference circuit input schematic for  $f = 2170 \text{ MHz}$

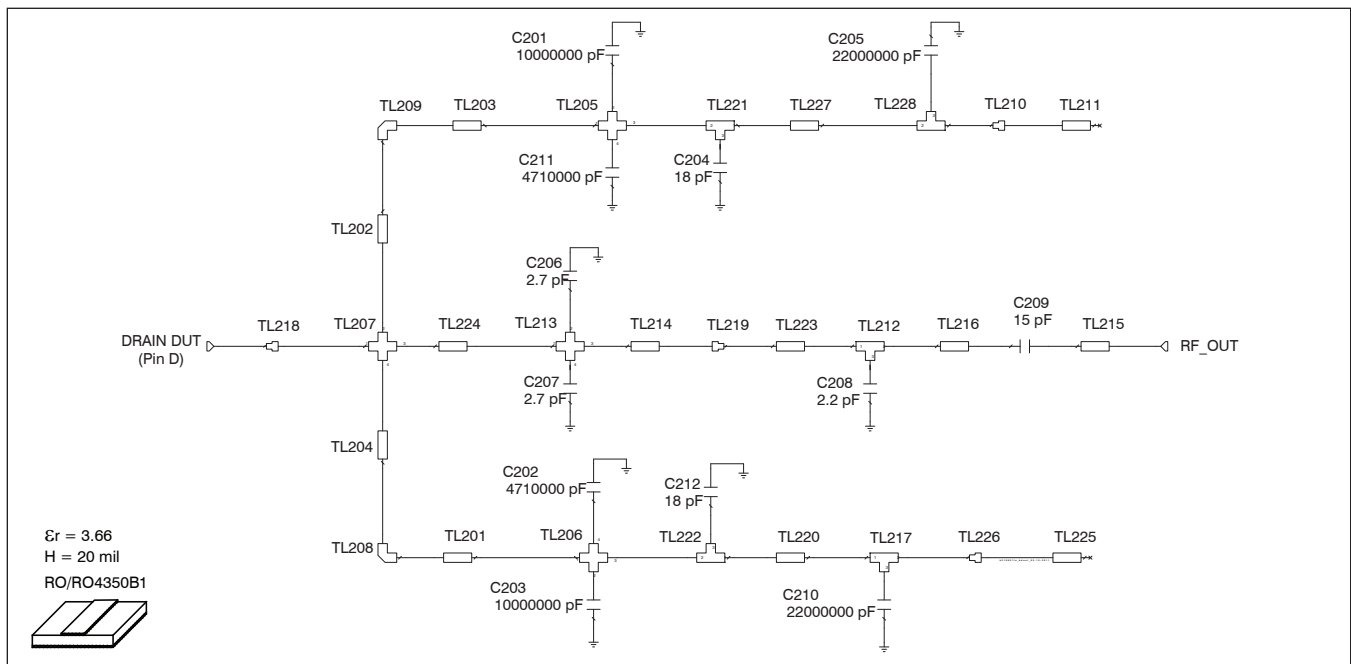

Reference circuit output schematic for  $f = 2170 \text{ MHz}$

## Reference Circuit (cont.)

Description	
DUT	PTFB210801FA
PCB	0.508 mm [.020"] thick, $\epsilon_r = 3.66$ , Rogers 4350, 1 oz. copper

## Electrical Characteristics at 2170 MHz

Transmission Line	Electrical Characteristics	Dimensions: mm	Dimensions: mils
<b>Input</b>			
TL101, TL117	0.023 $\lambda$ , 35.71 $\Omega$	W1 = 1.905, W2 = 1.905, W3 = 1.905	W1 = 75, W2 = 75, W3 = 75
TL102, TL115	0.012 $\lambda$ , 35.71 $\Omega$	W1 = 1.905, W2 = 1.905, W3 = 1.016	W1 = 75, W2 = 75, W3 = 40
TL103	0.021 $\lambda$ , 54.17 $\Omega$	W = 1.016, L = 1.778	W = 40, L = 70
TL104		W1 = 9.398, W2 = 1.270, W3 = 9.398, W4 = 1.270	W1 = 370, W2 = 50, W3 = 370, W4 = 40
TL105		W1 = 1.024, W2 = 9.398	W1 = 40, W2 = 370
TL106		W1 = 9.398, W2 = 9.398	W1 = 370, W2 = 370
TL107	0.050 $\lambda$ , 53.93 $\Omega$	W = 1.024, L = 4.153	W = 40, L = 164
TL108	0.025 $\lambda$ , 9.59 $\Omega$	W = 9.398, L = 1.905	W = 370, L = 75
TL109	0.019 $\lambda$ , 53.93 $\Omega$	W = 1.024, L = 1.605	W = 40, L = 63
TL110	0.092 $\lambda$ , 53.93 $\Omega$	W = 1.024, L = 7.696	W = 40, L = 303
TL111	0.072 $\lambda$ , 53.93 $\Omega$	W = 1.024, L = 5.994	W = 40, L = 236
TL112	0.011 $\lambda$ , 53.93 $\Omega$	W1 = 1.024, W2 = 1.024, W3 = 0.889	W1 = 40, W2 = 40, W3 = 35
TL113	0.212 $\lambda$ , 47.12 $\Omega$	W = 1.270, L = 17.577	W = 50, L = 692
TL114, TL121	0.039 $\lambda$ , 47.12 $\Omega$	W1 = 1.270, W2 = 1.270, W3 = 3.200	W1 = 50, W2 = 50, W3 = 126
TL116, TL122, TL123	0.016 $\lambda$ , 35.71 $\Omega$	W1 = 1.905, W2 = 1.905, W3 = 1.270	W1 = 75, W2 = 75, W3 = 50
TL118, TL120	0.004 $\lambda$ , 35.71 $\Omega$	W = 1.905, L = 0.361	W = 75, L = 14
TL119	0.021 $\lambda$ , 54.17 $\Omega$	W = 1.016, L = 1.778	W = 40, L = 70
TL124	0.039 $\lambda$ , 35.71 $\Omega$	W = 1.905, L = 3.172	W = 75, L = 125
TL125	0.048 $\lambda$ , 47.12 $\Omega$	W = 1.270, L = 4.013	W = 50, L = 158
TL126	0.071 $\lambda$ , 47.12 $\Omega$	W = 1.270, L = 5.906	W = 50, L = 233
TL127, TL128	0.005 $\lambda$ , 47.12 $\Omega$	W = 1.270, L = 0.406	W = 50, L = 16
TL129		W1 = 1.024, W2 = 2.032	W1 = 40, W2 = 80
TL130, TL131	0.012 $\lambda$ , 34.08 $\Omega$	W = 2.032, L = 1.016	W = 80, L = 40
TL132		W1 = 2.032, W2 = 1.024	W1 = 80, W2 = 40

table continued on page 7

## Reference Circuit (cont.)

## Electrical Characteristics at 2170 MHz

Transmission Line	Electrical Characteristics	Dimensions: mm	Dimensions: mils
Output			
TL201, TL203	0.009 $\lambda$ , 47.12 $\Omega$	W = 1.270, L = 0.762	W = 50, L = 30
TL202, TL204	0.064 $\lambda$ , 47.12 $\Omega$	W = 1.270, L = 5.334	W = 50, L = 210
TL205, TL206		W1 = 1.905, W2 = 2.540, W3 = 1.905 W4 = 2.540	W1 = 75, W2 = 100, W3 = 75, W4 = 100
TL207		W1 = 9.398, W2 = 1.270, W3 = 9.398 W4 = 1.270	W1 = 370, W2 = 50, W3 = 370, W4 = 50
TL208, TL209		W = 1.270	W = 50
TL210		W1 = 0.002, W2 = 0.005, Offset = 0.001	W1 = 2, W2 = 184, Offset = 55
TL211, TL225	0.172 $\lambda$ , 17.67 $\Omega$	W = 4.674, L = 13.564	W = 184, L = 534
TL212	0.011 $\lambda$ , 53.93 $\Omega$	W1 = 1.024, W2 = 1.024, W3 = 0.889	W1 = 40, W2 = 40, W3 = 35
TL213		W1 = 9.398, W2 = 0.889, W3 = 9.398 W4 = 0.889	W1 = 370, W2 = 35, W3 = 370, W4 = 35
TL214	0.016 $\lambda$ , 9.59 $\Omega$	W = 9.398, L = 1.219	W = 370, L = 48
TL215	0.032 $\lambda$ , 53.93 $\Omega$	W = 1.024, L = 2.713	W = 40, L = 107
TL216	0.185 $\lambda$ , 53.93 $\Omega$	W = 1.024, L = 15.491	W = 40, L = 610
TL217, TL228	0.002 $\lambda$ , 35.71 $\Omega$	W1 = 1.905, W2 = 1.905, W3 = 0.127	W1 = 75, W2 = 75, W3 = 5
TL218		W1 = 9.398, W2 = 9.398	W1 = 370, W2 = 370
TL219		W1 = 1.024, W2 = 9.398	W1 = 40, W2 = 370
TL220, TL227	0.068 $\lambda$ , 35.71 $\Omega$	W = 1.905, L = 5.588	W = 75, L = 220
TL221, TL222	0.016 $\lambda$ , 35.71 $\Omega$	W1 = 1.905, W2 = 1.905, W3 = 1.270	W1 = 75, W2 = 75, W3 = 50
TL223	0.012 $\lambda$ , 53.93 $\Omega$	W = 1.024, L = 0.991	W = 40, L = 39
TL224	0.011 $\lambda$ , 9.59 $\Omega$	W = 9.398, L = 0.813	W = 370, L = 32
TL226		W1 = 0.002, W2 = 0.005, Offset = -0.001	W1 = 2, W2 = 184, Offset = -55





### Reference Circuit (cont.)

#### Circuit Assembly Information

Test Fixture Part No. LTN/PTFB210801FA

Find Gerber files for this test fixture on the Wolfspeed Web site at [www.wolfspeed.com/RF](http://www.wolfspeed.com/RF)

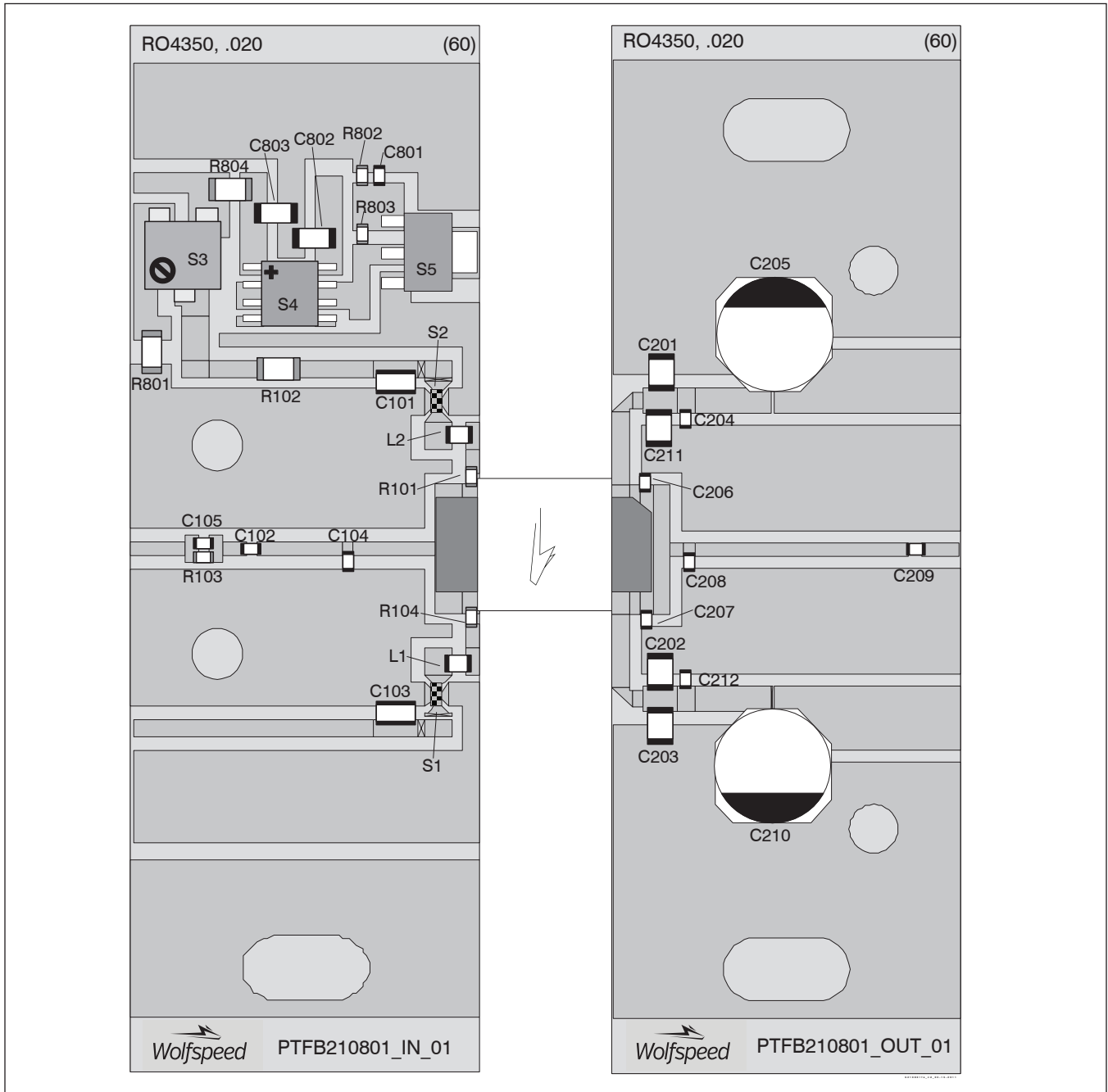

Reference circuit assembly diagram (not to scale)

**Reference Circuit** (cont.)**Components Information**

Component	Description	Suggested Manufacturer	P/N
<b>Input</b>			
C101, C103	Capacitor, 10 $\mu$ F	Digi-Key	490-4393-2-ND
C102, C105	Chip capacitor, 15 pF	ATC	800A150GT
C104	Chip capacitor, 1.5 pF	ATC	800A1T5GR
C801, C802, C803	Capacitor, 1000 pF	Digi-Key	PCC1772CT-ND
L1, L2	Inductor, 22 nH	Coilcraft	0805CS-220X_BG
R101, R103, R104	Resistor, 10 $\Omega$	Digi-Key	P10GCT-ND
R102, R804	Resistor, 2000 $\Omega$	Digi-Key	P2.0KECT-ND
R801	Resistor, 3000 $\Omega$	Digi-Key	P3.0KECT-ND
R802	Resistor, 1300 $\Omega$	Digi-Key	P1.3KGECT-ND
R803	Resistor, 1200 $\Omega$	Digi-Key	P1.2KGECT-ND
S1, S2	EMI Suppression Capacitor	Digi-Key	NFM18PS105R0J3D
S3	Potentiometer, 2k $\Omega$	Digi-Key	3224W-202ECT-ND
S4	Voltage Regulator	Digi-Key	LM7805
S5	Transistor	Digi-Key	BCP56
<b>Output</b>			
C201, C203	Capacitor, 10 $\mu$ F	Digi-Key	587-1818-2-ND
C202, C211	Chip capacitor, 4.71 $\mu$ F	ATC	490-1864-2-ND
C204, C212	Chip capacitor, 18 pF	ATC	800A180JT
C205, C210	Capacitor, 22 $\mu$ F	Digi-Key	PCE4444TR-ND
C206, C207	Chip capacitor, 2.7 pF	ATC	800A2R7BT
C208	Chip capacitor, 2.2 pF	ATC	800A2R2BT
C209	Chip capacitor, 15 pF	ATC	800A150GT

## Package Outline Specifications

### Package H-37265-2

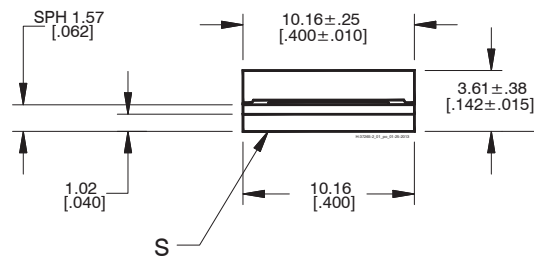
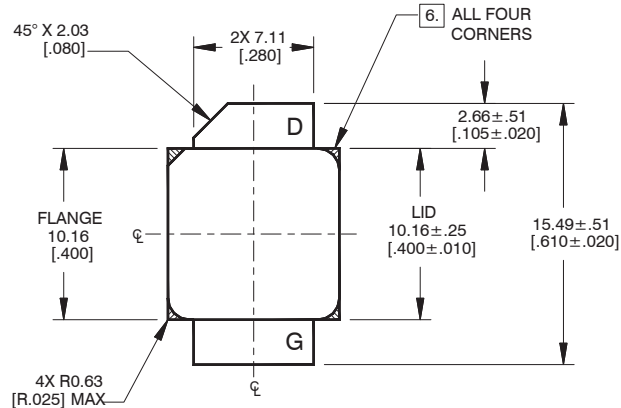

Diagram Notes—unless otherwise specified:

1. Interpret dimensions and tolerances per ASME Y14.5M-1994.
2. Primary dimensions are mm. Alternate dimensions are inches.
3. All tolerances  $\pm 0.127$  [0.005] unless specified otherwise.
4. Pins: D = drain, S = source, G = gate.
5. Lead thickness:  $0.10 + 0.051 / - 0.025$  [0.004 + 0.002 / - 0.001].
6. Exposed metal plane on top and bottom of ceramic insulator.
7. Gold plating thickness:  $1.14 \pm 0.38$  micron [45 ± 15 microinch]

## Revision History

Revision	Date	Data Sheet Type	Page	Subjects (major changes at each revision)
01	2011-03-30	Production	All	Data Sheet reflects advance specification for product development
01.1	2016-06-14	Production	2	Updated ordering information
02	2018-06-27	Production	All	Converted to Wolfspeed Data Sheet

For more information, please contact:

4600 Silicon Drive  
 Durham, North Carolina, USA 27703  
[www.wolfspeed.com/RF](http://www.wolfspeed.com/RF)

Sales Contact  
[RFSales@wolfspeed.com](mailto:RFSales@wolfspeed.com)

RF Product Marketing Contact  
[RFMarketing@wolfspeed.com](mailto:RFMarketing@wolfspeed.com)  
 919.407.7816

## Notes

---

### Disclaimer

Specifications are subject to change without notice. Cree, Inc. believes the information contained within this data sheet to be accurate and reliable. However, no responsibility is assumed by Cree for any infringement of patents or other rights of third parties which may result from its use. No license is granted by implication or otherwise under any patent or patent rights of Cree. Cree makes no warranty, representation or guarantee regarding the suitability of its products for any particular purpose. "Typical" parameters are the average values expected by Cree in large quantities and are provided for information purposes only. These values can and do vary in different applications and actual performance can vary over time. All operating parameters should be validated by customer's technical experts for each application. Cree products are not designed, intended or authorized for use as components in applications intended for surgical implant into the body or to support or sustain life, in applications in which the failure of the Cree product could result in personal injury or death or in applications for planning, construction, maintenance or direct operation of a nuclear facility.