



Chipsmall Limited consists of a professional team with an average of over 10 year of expertise in the distribution of electronic components. Based in Hongkong, we have already established firm and mutual-benefit business relationships with customers from,Europe,America and south Asia,supplying obsolete and hard-to-find components to meet their specific needs.

With the principle of “Quality Parts,Customers Priority,Honest Operation,and Considerate Service”,our business mainly focus on the distribution of electronic components. Line cards we deal with include Microchip,ALPS,ROHM,Xilinx,Pulse,ON,Everlight and Freescale. Main products comprise IC,Modules,Potentiometer,IC Socket,Relay,Connector.Our parts cover such applications as commercial,industrial, and automotives areas.

We are looking forward to setting up business relationship with you and hope to provide you with the best service and solution. Let us make a better world for our industry!



## Contact us

Tel: +86-755-8981 8866 Fax: +86-755-8427 6832

Email & Skype: info@chipsmall.com Web: www.chipsmall.com

Address: A1208, Overseas Decoration Building, #122 Zhenhua RD., Futian, Shenzhen, China



# PTN3300A

DVI/HDMI level shifter with inverting 1.1 V HPD

Rev. 01 — 30 June 2008

Product data sheet

## 1. General description

The PTN3300A is a high-speed level shifter device which converts four lanes of low-swing AC-coupled differential input signals to DVI and HDMI compliant open-drain current-steering differential output signals, up to 2.25 Gbit/s per lane. Each of these lanes provides a level-shifting differential buffer to translate from low-swing AC-coupled differential signaling on the source side, to TMDS-type DC-coupled differential current-mode signaling terminated into 50  $\Omega$  to 3.3 V on the sink side. Additionally, the PTN3300A provides a single-ended active inverting buffer for voltage translation of the HPD signal from 5 V on the sink side to 1.1 V on the source side and provides a channel for level shifting of the DDC channel (consisting of a clock and a data line) between 3.3 V source-side and 5 V sink-side. The DDC channel is implemented using pass gate technology allowing level shifting as well as disablement (isolation between source and sink) of the clock and data lines.

The low-swing AC-coupled differential input signals to the PTN3300A typically come from a display source with multi-mode I/O, which supports multiple display standards, e.g., DisplayPort, HDMI and DVI. While the input differential signals are configured to carry DVI or HDMI coded data, they do not comply with the electrical requirements of the DVI v1.0 specification or HDMI v1.3a specification. By using PTN3300A, chip set vendors are able to implement such reconfigurable I/Os on multi-mode display source devices, allowing the support of multiple display standards while keeping the number of chip set I/O pins low. See [Figure 1](#).

The PTN3300A main high-speed differential lanes feature low-swing self-biasing differential inputs which are compliant to the electrical specifications of *DisplayPort Standard v1.1* and/or *PCI Express Standard v1.1*, and open-drain current-steering differential outputs compliant to DVI v1.0 and HDMI V1.3a electrical specifications. The PTN3300A also supports power-saving modes in order to minimize current consumption when no display is active or connected.

The PTN3300A supports level translation functions and features supporting DVI and HDMI. It is identical to the PTN3300B except that the HPD\_SOURCE\_N output is the logic inverse function of input HPD\_SINK, level shifted to 1.1 V. For a fully-featured HDMI/DVI level shifter function that supports active buffering of the DDC lines and HDMI dongle detect, the PTN3301 should be used.

PTN3300A is powered from a single 3.3 V power supply consuming a small amount of power (120 mW typ.) and is offered in two different 48-terminal HWQFN packages, one laminate based (no terminals visible from edge of the package), and one leadframe-based (terminals visible from edge of the package).

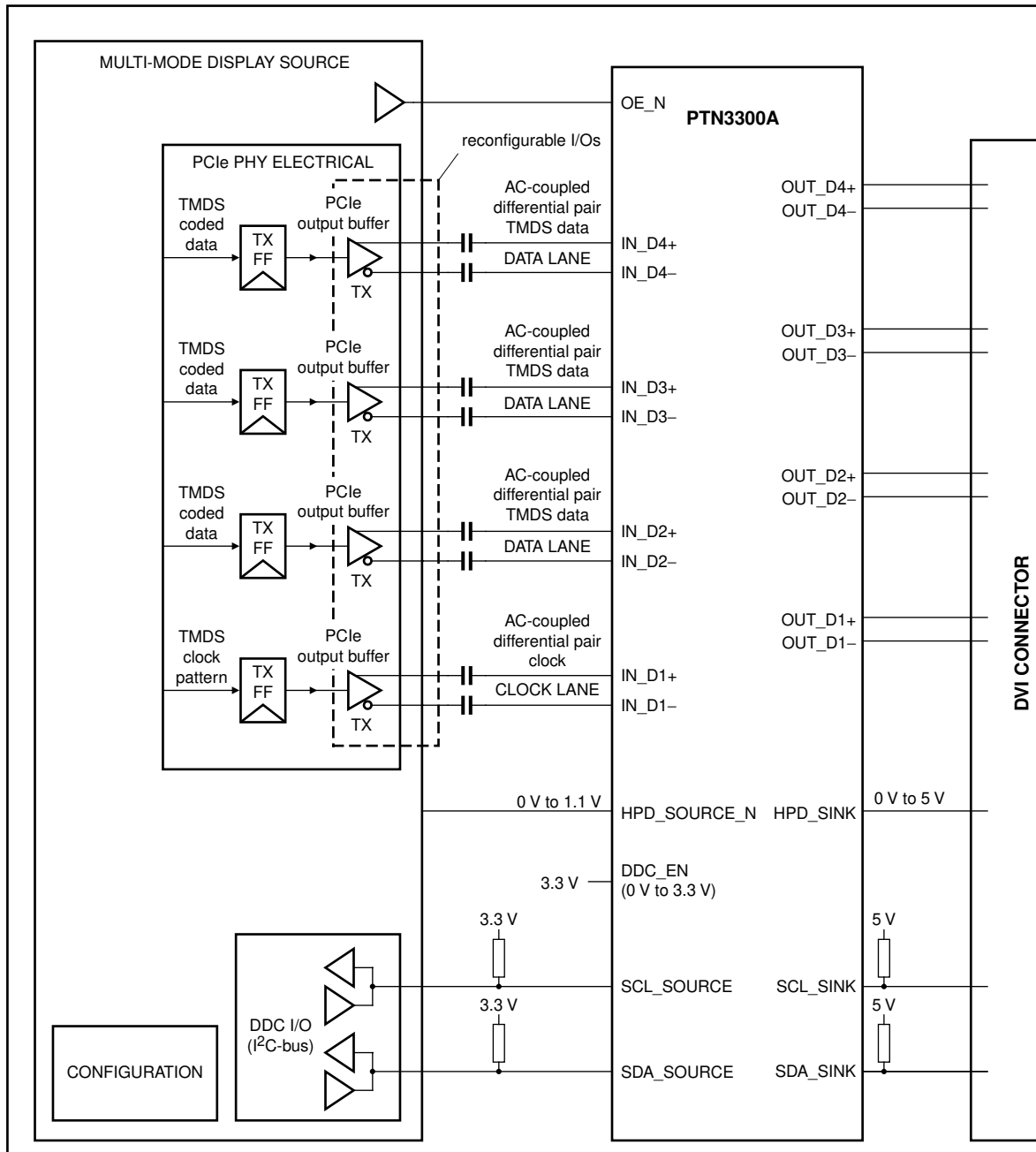

002aad645

**Remark:** TMDS clock and data lanes can be assigned arbitrarily and interchangeably to D[4:1].

**Fig 1. Typical application system diagram**



## 2. Features

### 2.1 High-speed TMDS level shifting

- Converts four lanes of low-swing AC-coupled differential input signals to DVI and HDMI compliant open-drain current-steering differential output signals
- TMDS level shifting operation up to 2.25 Gbit/s per lane (225 MHz character clock)
- Integrated 50 Ω termination resistors for self-biasing differential inputs
- Back-current safe outputs to disallow current when device power is off and monitor is on
- Disable feature to turn off TMDS inputs and outputs and to enter low-power state

### 2.2 DDC level shifting

- Integrated DDC level shifting (3.3 V source to 5 V sink side)
- 0 Hz to 400 kHz clock frequency
- Back-power safe to disallow backdrive current when power is off or when DDC is not enabled

### 2.3 HPD level shifting

- HPD **inverting** level shift from 0 V on the sink side to 1.1 V on the source side, or from 5 V on the sink side to 0 V on the source side
- Integrated 200 kΩ pull-down resistor on HPD sink input guarantees 'input LOW' when no display is plugged in

### 2.4 General

- Power supply 3.3 V ± 10 %
- ESD resilience to 3.5 kV HBM, 1 kV CDM
- Power-saving modes by source-side disablement (using output enable) as well as sink-side detection (using HPD)
- Back-current-safe design on all sink-side terminals
- Transparent operation: no re-timing or software configuration required

## 3. Ordering information

Table 1. Ordering information

Type number	Package		
	Name	Description	Version
PTN3300AHF	HWQFN48R	plastic thermal enhanced very very thin quad flat package; no leads; 48 terminals; resin based; body 7 × 7 × 0.7 mm	SOT1031-2
PTN3300AHF2	HWQFN48	plastic thermal enhanced very very thin quad flat package; no leads; 48 terminals; body 7 × 7 × 0.65 mm	SOT1074-1

4. Functional diagram

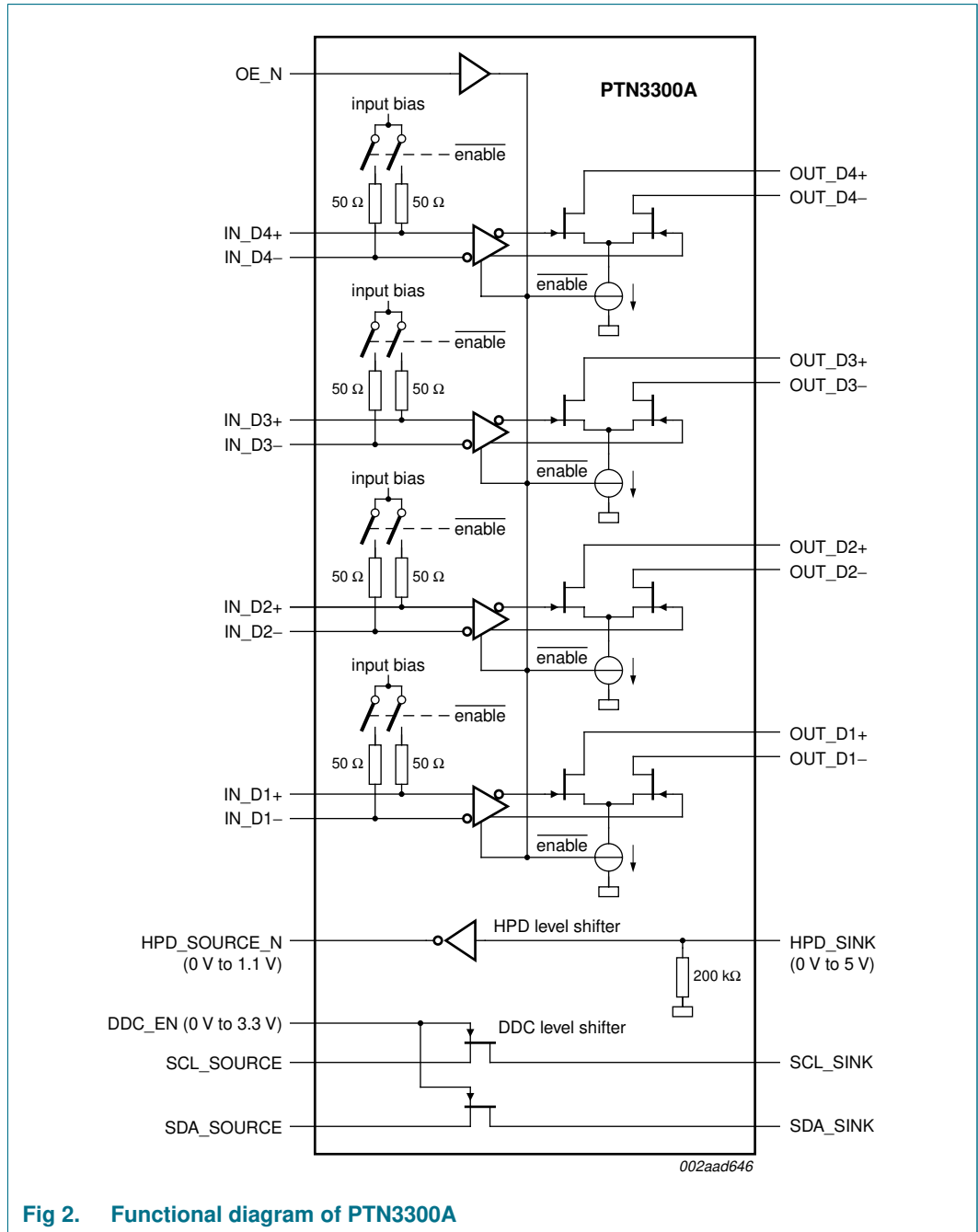
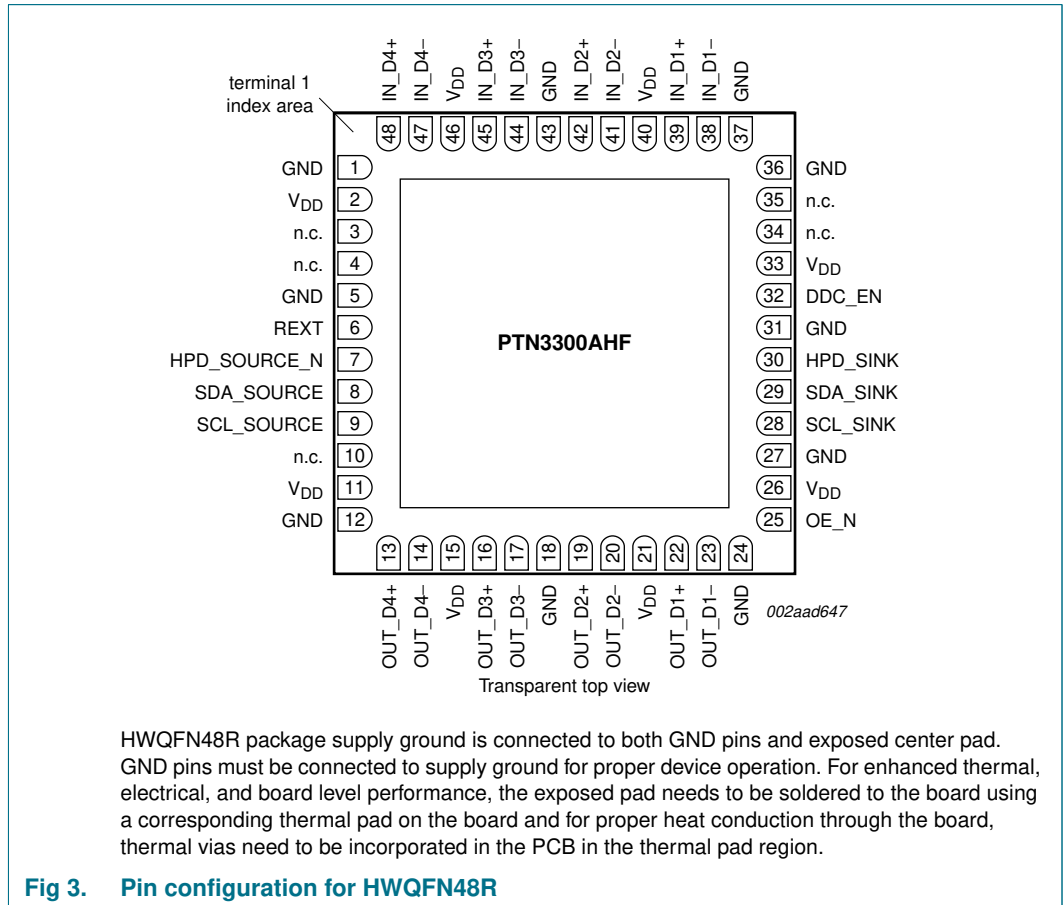
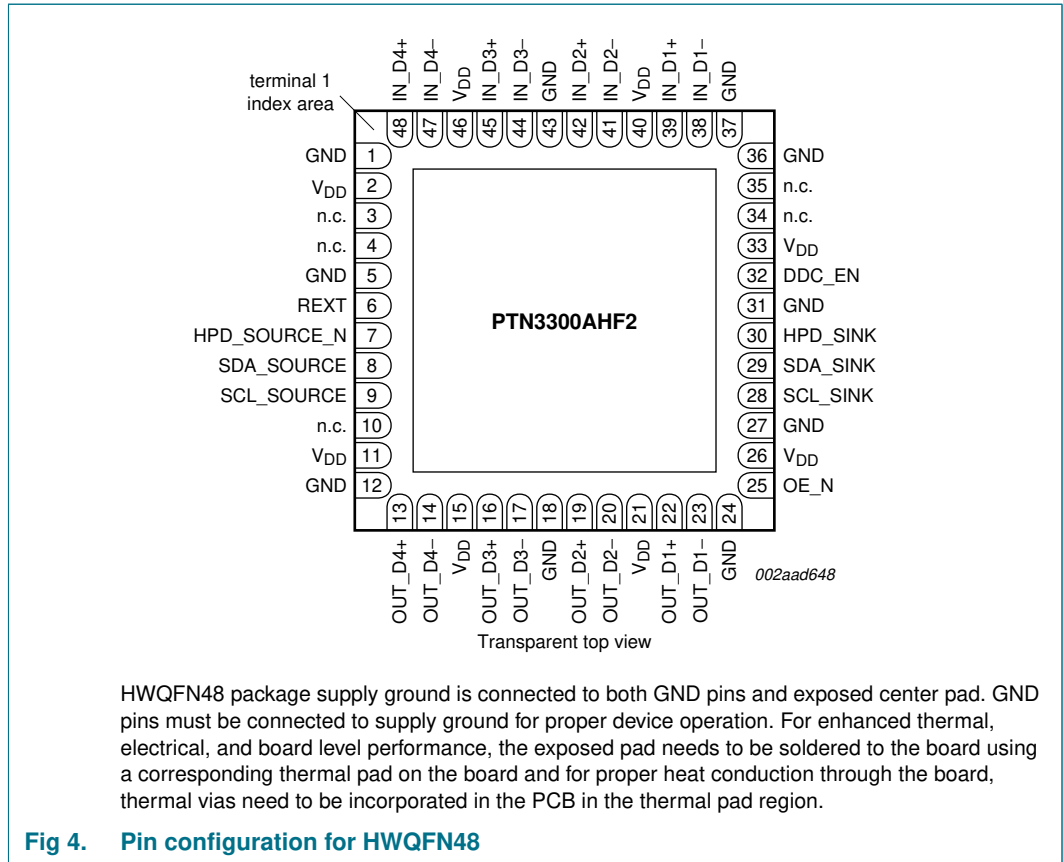

Fig 2. Functional diagram of PTN3300A

## 5. Pinning information

### 5.1 Pinning





## 5.2 Pin description

Table 2. Pin description

Symbol	Pin	Type	Description
<b>OE_N, IN_Dx and OUT_Dx signals</b>			
OE_N	25	3.3 V low-voltage CMOS single-ended input	Output Enable and power saving function for high-speed differential level shifter path. When OE_N = HIGH: IN_Dx termination = high-impedance OUT_Dx outputs = high-impedance; zero output current When OE_N = LOW: IN_Dx termination = 50 Ω OUT_Dx outputs = active
IN_D4+	48	Self-biasing differential input	Low-swing differential input from display source with PCI Express electrical signalling. IN_D4+ makes a differential pair with IN_D4-. The input to this pin must be AC coupled externally.
IN_D4-	47	Self-biasing differential input	Low-swing differential input from display source with PCI Express electrical signalling. IN_D4- makes a differential pair with IN_D4+. The input to this pin must be AC coupled externally.
IN_D3+	45	Self-biasing differential input	Low-swing differential input from display source with PCI Express electrical signalling. IN_D3+ makes a differential pair with IN_D3-. The input to this pin must be AC coupled externally.
IN_D3-	44	Self-biasing differential input	Low-swing differential input from display source with PCI Express electrical signalling. IN_D3- makes a differential pair with IN_D3+. The input to this pin must be AC coupled externally.
IN_D2+	42	Self-biasing differential input	Low-swing differential input from display source with PCI Express electrical signalling. IN_D2+ makes a differential pair with IN_D2-. The input to this pin must be AC coupled externally.
IN_D2-	41	Self-biasing differential input	Low-swing differential input from display source with PCI Express electrical signalling. IN_D2- makes a differential pair with IN_D2+. The input to this pin must be AC coupled externally.
IN_D1+	39	Self-biasing differential input	Low-swing differential input from display source with PCI Express electrical signalling. IN_D1+ makes a differential pair with IN_D1-. The input to this pin must be AC coupled externally.
IN_D1-	38	Self-biasing differential input	Low-swing differential input from display source with PCI Express electrical signalling. IN_D1- makes a differential pair with IN_D1+. The input to this pin must be AC coupled externally.
OUT_D4+	13	TMDS differential output	DVI and HDMI compliant TMDS output. OUT_D4+ makes a differential pair with OUT_D4-. OUT_D4+ is in phase with IN_D4+.
OUT_D4-	14	TMDS differential output	DVI and HDMI compliant TMDS output. OUT_D4- makes a differential pair with OUT_D4+. OUT_D4- is in phase with IN_D4-.
OUT_D3+	16	TMDS differential output	DVI and HDMI compliant TMDS output. OUT_D3+ makes a differential pair with OUT_D3-. OUT_D3+ is in phase with IN_D3+.
OUT_D3-	17	TMDS differential output	DVI and HDMI compliant TMDS output. OUT_D3- makes a differential pair with OUT_D3+. OUT_D3- is in phase with IN_D3-.
OUT_D2+	19	TMDS differential output	DVI and HDMI compliant TMDS output. OUT_D2+ makes a differential pair with OUT_D2-. OUT_D2+ is in phase with IN_D2+.
OUT_D2-	20	TMDS differential output	DVI and HDMI compliant TMDS output. OUT_D2- makes a differential pair with OUT_D2+. OUT_D2- is in phase with IN_D2-.



Table 2. Pin description ...continued

Symbol	Pin	Type	Description
OUT_D1+	22	TMDS differential output	DVI and HDMI compliant TMDS output. OUT_D1+ makes a differential pair with OUT_D1-. OUT_D1+ is in phase with IN_D1+.
OUT_D1-	23	TMDS differential output	DVI and HDMI compliant TMDS output. OUT_D1- makes a differential pair with OUT_D1+. OUT_D1- is in phase with IN_D1-.
<b>HPD and DDC signals</b>			
HPD_SINK	30	5 V CMOS single-ended input	0 V to 5 V (nominal) input signal. This signal comes from the DVI or HDMI sink. A HIGH value indicates that the DVI or HDMI sink is connected; a LOW value indicates that the sink is disconnected. HPD_SINK is pulled down by an integrated 200 kΩ pull-down resistor. A LOW input level on this pin will automatically put the PTN3300A in Standby mode for lowest power consumption.
HPD_SOURCE_N	7	1.1 V CMOS single-ended output	0 V to 1.1 V (nominal) output signal. This is the level-shifted <b>logic-inverted</b> version of the HPD_SINK signal.
SCL_SOURCE	9	single-ended 3.3 V DDC I/O pass gate	3.3 V source-side DDC clock I/O. Pulled up by external termination to 3.3 V.
SDA_SOURCE	8	single-ended 3.3 V DDC I/O pass gate	3.3 V source-side DDC data I/O. Pulled up by external termination to 3.3 V.
SCL_SINK	28	single-ended 5 V DDC I/O pass gate	5 V sink-side DDC clock I/O. Pulled up by external termination to 5 V.
SDA_SINK	29	single-ended 5 V DDC I/O pass gate	5 V sink-side DDC data I/O. Pulled up by external termination to 5 V.
DDC_EN	32	3.3 V CMOS input	Enables the DDC level shifter path. When DDC_EN = LOW, DDC level shifter is disabled. When DDC_EN = HIGH, DDC level shifter are enabled. Note that HPD_SINK needs to be HIGH for the DDC channel to be enabled.
<b>Supply and ground</b>			
V <sub>DD</sub>	2, 11, 15, 21, 26, 33, 40, 46	3.3 V DC supply	Supply voltage; 3.3 V ± 10 %.
GND <sup>[1]</sup>	1, 5, 12, 18, 24, 27, 31, 36, 37, 43	ground	Supply ground. All ground pins must be connected to ground for proper operation.
<b>Feature control signals</b>			
REXT	6	analog I/O	Current sense port used to provide an accurate current reference for the differential outputs OUT_Dx. For best output voltage swing accuracy, use of a 10 kΩ resistor (1 % tolerance) from this terminal to GND is recommended. May also be left open-circuit or tied to either V <sub>DD</sub> or GND.
<b>Miscellaneous</b>			
n.c.	3, 4, 10, 34, 35	no connection to the die	Not connected. May be left open-circuit or tied to GND or V <sub>DD</sub> either directly or via a resistor.

[1] HWQFN48R and HWQFN48 package supply ground is connected to both GND pins and exposed center pad. GND pins must be connected to supply ground for proper device operation. For enhanced thermal, electrical, and board level performance, the exposed pad needs to be soldered to the board using a corresponding thermal pad on the board and for proper heat conduction through the board, thermal vias need to be incorporated in the PCB in the thermal pad region.

## 6. Functional description

Refer to [Figure 2 “Functional diagram of PTN3300A”](#).

The PTN3300A level shifts four lanes of low-swing AC-coupled differential input signals to DVI or HDMI compliant open-drain current-steering differential output signals, up to 2.25 Gbit/s per lane. It has integrated 50  $\Omega$  termination resistors for AC-coupled differential input signals. An enable signal OE\_N can be used to turn off the TMDS inputs and outputs, thereby minimizing power consumption. The TMDS outputs are back-power safe to disallow current flow from a powered sink while the PTN3300A is unpowered.

The PTN3300A's DDC level-shifter allows 3.3 V source-side termination and 5 V sink-side termination. The PTN3300A offers the back-power safe feature to disallow backdrive current from the DDC clock and data lines when power is off or when DDC is not enabled. An enable signal DCC\_EN enables the level shifter block.

The PTN3300A also provides voltage translation for the Hot Plug Detect (HPD) signal from 0 V/5 V on the sink side, inverting and level-shifting to 1.1 V/0 V on the source side. PTN3300A also automatically goes into low power mode when the sink is not connected (HPD\_SINK is LOW).

The PTN3300A does not re-time any data. It contains no state machines. No inputs or outputs of the device are latched or clocked. Because the PTN3300A acts as a transparent level shifter, no reset is required.

### 6.1 Flexible and power-efficient enable and disable features

PTN3300A offers different ways to enable or disable functionality, using the Output Enable (OE\_N), Hot Plug Detect (HPD\_SINK) and DDC Enable (DDC\_EN) inputs. Whenever the PTN3300A is disabled using HPD\_SINK or OE\_N, the device will be in Standby mode and power consumption will be minimal; otherwise the PTN3300A will be in Active mode and power consumption will be nominal. These three inputs each affect the operation of PTN3300A differently: OE\_N affects only the TMDS channels, DDC\_EN affects only the DDC channel, and HPD\_SINK affects both TMDS and DDC channels. The following sections and truth table describe their detailed operation.

#### 6.1.1 Hot plug detect with power-saving feature

The HPD channel of PTN3300A in fact has a dual function: as a level-shifting inverting buffer to pass the HPD logic signal from the display sink device (via input HPD\_SINK) on to the display source device (via output HPD\_SOURCE\_N), as well as a detection input for determining when the PTN3300A will go into Standby mode to save power consumption.

The PTN3300A will automatically disable both the TMDS and DDC channels when the HPD input indicates that no display is connected (indicated by HPD\_SINK = LOW), upon which power consumption is minimized. The power-down behavior in HPD power-saving mode is identical to the active disablement using both the OE\_N input and the DDC\_EN input.

The logic state of the HPD\_SOURCE\_N output always follows the inverse logic state of the HPD\_SINK input, regardless of whether the device is in Active or Standby mode.

### 6.1.2 Output Enable function (OE\_N)

When input OE\_N is asserted (active LOW), the IN\_Dx and OUT\_Dx signals are fully functional provided that HPD\_SINK input is HIGH. Input termination resistors are enabled and the internal bias circuits are turned on.

When OE\_N is de-asserted (inactive HIGH), the OUT\_Dx outputs are in a high-impedance state and drive zero output current. The IN\_Dx input buffers are disabled and IN\_Dx termination is disabled. Internal bias circuits for the differential inputs and outputs are turned off. Power consumption is minimized.

**Remark:** Note that OE\_N has no influence on the HPD\_SINK input, HPD\_SOURCE\_N output, or the SCL and SDA level shifters. OE\_N only affects the high-speed TMDS channel.

### 6.1.3 DDC channel enable function (DDC\_EN)

The DDC\_EN pin is active HIGH and can be used to isolate a badly behaved slave. When DDC\_EN is LOW, the DDC channel is turned off. The DDC\_EN input should never change state during an I<sup>2</sup>C-bus operation. Note that disabling DDC\_EN during a bus operation will hang the bus, while enabling DDC\_EN during bus traffic would corrupt the I<sup>2</sup>C-bus operation. Hence, DDC\_EN should only be toggled while the bus is idle. (See I<sup>2</sup>C-bus specification).

### 6.1.4 Enable/disable truth table

Table 3. HPD\_SINK, OE\_N and DDC\_EN enabling and power saving functions truth table

Inputs			Channels				Mode
HPD_SINK <a href="#">[1]</a>	OE_N <a href="#">[2]</a>	DDC_EN <a href="#">[3]</a>	IN_Dx	OUT_Dx <a href="#">[4]</a>	DDC <a href="#">[5]</a>	HPD_SOURCE_N <a href="#">[6]</a>	
LOW	X	X	high-impedance	high-impedance; zero output current	high-impedance	HIGH	Standby
HIGH	LOW	LOW	50 Ω termination to V <sub>RX(bias)</sub>	enabled	high-impedance	LOW	Active
HIGH	LOW	HIGH	50 Ω termination to V <sub>RX(bias)</sub>	enabled	enabled	LOW	Active
HIGH	HIGH	LOW	high-impedance	high-impedance; zero output current	high-impedance	LOW	Standby
HIGH	HIGH	HIGH	high-impedance	high-impedance; zero output current	enabled	LOW	Standby with DDC channel enabled

[1] A LOW level on input HPD\_SINK disables both the TMDS and DDC channels.

[2] A HIGH level on input OE\_N disables only the TMDS channels.

[3] A LOW level on input DDC\_EN disables only the DDC channel.

[4] OUT\_Dx channels 'enabled' means outputs OUT\_Dx toggling in accordance with IN\_Dx differential input voltage switching.

[5] DDC channel 'enabled' means SDA\_SINK is connected to SDA\_SOURCE and SCL\_SINK is connected to SCL\_SOURCE.

[6] The HPD\_SOURCE\_N output logic state follows the inverse of the HPD\_SINK input logic state regardless of Active or Standby mode.

## 6.2 Analog current reference

The REXT pin (pin 6) is an analog current sense port used to provide an accurate current reference for the differential outputs OUT\_Dx. For best output voltage swing accuracy, use of a 10 k $\Omega$  resistor (1 % tolerance) connected between this terminal and GND is recommended.

If an external 10 k $\Omega$   $\pm$  1 % resistor is not used, this pin can be left open-circuit, or connected to GND or V<sub>DD</sub>, either directly (0  $\Omega$ ) or using pull-up or pull-down resistors of value less than 10 k $\Omega$ . In any of these cases, the output will function normally but at reduced accuracy over voltage and temperature of the following parameters: output levels (V<sub>OL</sub>), differential output voltage swing, and rise and fall time accuracy.

## 6.3 Backdrive current protection

The PTN3300A is designed for backdrive prevention on all sink-side terminals. This supports user scenarios where the display is connected and powered, but the PTN3300A is unpowered. In these cases, the PTN3300A will sink no more than a negligible amount of leakage current, and will block the display (sink) termination network from driving the power supply of the PTN3300A or that of the inactive DVI or HDMI source.

## 7. Limiting values

**Table 4. Limiting values**

*In accordance with the Absolute Maximum Rating System (IEC 60134).*

Symbol	Parameter	Conditions	Min	Max	Unit
V <sub>DD</sub>	supply voltage		-0.3	+4.6	V
V <sub>I</sub>	input voltage	3.3 V CMOS inputs	-0.3	V <sub>DD</sub> + 0.5	V
		5.0 V CMOS inputs	-0.3	6.0	V
T <sub>stg</sub>	storage temperature		-65	+150	°C
V <sub>esd</sub>	electrostatic discharge voltage	HBM	[1] -	3500	V
		CDM	[2] -	1000	V

[1] Human Body Model: ANSI/EOS/ESD-S5.1-1994, standard for ESD sensitivity testing, Human Body Model - Component level; Electrostatic Discharge Association, Rome, NY, USA.

[2] Charged Device Model: ANSI/EOS/ESD-S5.3-1-1999, standard for ESD sensitivity testing, Charged Device Model - Component level; Electrostatic Discharge Association, Rome, NY, USA.

## 8. Recommended operating conditions

**Table 5. Recommended operating conditions**

Symbol	Parameter	Conditions	Min	Typ	Max	Unit
V <sub>DD</sub>	supply voltage		3.0	3.3	3.6	V
V <sub>I</sub>	input voltage	3.3 V CMOS inputs	0	-	3.6	V
		5.0 V CMOS inputs	0	-	5.5	V
V <sub>I(AV)</sub>	average input voltage	DC value at IN_Dn+, IN_Dn- inputs	[1] -	0	-	V
R <sub>ref(ext)</sub>	external reference resistance [2]	connected between REXT pin (pin 6) and GND; ± 1 %	-	10	-	kΩ
T <sub>amb</sub>	ambient temperature	operating in free air	-40	-	+85	°C

[1] Input signals to these pins must be AC-coupled.

[2] Operation without external reference resistor is possible but will result in reduced output voltage swing accuracy. For details, see [Section 6.2](#).

### 8.1 Current consumption

**Table 6. Current consumption**

Symbol	Parameter	Conditions	Min	Typ	Max	Unit
I <sub>DD</sub>	supply current	OE_N = 0 and HPD_SINK = 1; Active mode	10	35	50	mA
		OE_N = 1 or HPD_SINK = 0; Standby mode	-	5	50	μA



## 9. Characteristics

### 9.1 Differential inputs

**Table 7. Differential input characteristics for IN\_Dx signals**

Symbol	Parameter	Conditions	Min	Typ	Max	Unit
UI	unit interval <sup>[1]</sup>		<sup>[2]</sup> 400	-	4000	ps
V <sub>RX_DIFFp-p</sub>	differential input peak-to-peak voltage		<sup>[3]</sup> 0.175	-	1.200	V
T <sub>RX_EYE</sub>	receiver eye time	minimum eye width at IN_Dx input pair	0.8	-	-	UI
V <sub>i(cm)M(AC)</sub>	peak common-mode input voltage (AC)	includes all frequencies above 30 kHz	<sup>[4]</sup> -	-	100	mV
Z <sub>RX_DC</sub>	DC input impedance		40	50	60	Ω
V <sub>RX(bias)</sub>	bias receiver voltage	voltage at IN_Dx when IN_Dx = open circuit	<sup>[5]</sup> 1.0	1.2	1.4	V
Z <sub>i(se)</sub>	single-ended input impedance	inputs in high-impedance state	<sup>[6]</sup> 100	-	-	kΩ

[1] UI (unit interval) = t<sub>bit</sub> (bit time).

[2] UI is determined by the display mode. Nominal bit rate ranges from 250 Mbit/s to 2.25 Gbit/s per lane. Nominal UI at 2.25 Gbit/s = 444 ps. 400 ps = 444 ps – 10 %.

[3] V<sub>RX\_DIFFp-p</sub> = 2 × |V<sub>RX\_D+</sub> – V<sub>RX\_D-</sub>|. Applies to IN\_Dx signals.

[4] V<sub>i(cm)M(AC)</sub> = |V<sub>RX\_D+</sub> + V<sub>RX\_D-</sub>| / 2 – V<sub>RX(cm)</sub>.  
V<sub>RX(cm)</sub> = DC (avg) of |V<sub>RX\_D+</sub> + V<sub>RX\_D-</sub>| / 2.

[5] Intended to limit power-up stress on source side PCIe output buffers.

[6] Differential inputs will switch to a high-impedance state when OE\_N is LOW.

## 9.2 Differential outputs

The level shifter's differential outputs are designed to meet DVI version 1.0 and HDMI v1.3a specifications.

**Table 8. Differential output characteristics for OUT\_Dx signals**

Symbol	Parameter	Conditions	Min	Typ	Max	Unit
$V_{OH(se)}$	single-ended HIGH-level output voltage		[1] $V_{TT} - 0.01$	$V_{TT}$	$V_{TT} + 0.01$	V
$V_{OL(se)}$	single-ended LOW-level output voltage		[2] $V_{TT} - 0.60$	$V_{TT} - 0.50$	$V_{TT} - 0.40$	V
$\Delta V_{O(se)}$	single-ended output voltage variation	logic 1 and logic 0 state applied respectively to differential inputs IN_Dn; $R_{ref(ext)}$ connected. See <a href="#">Table 5</a>	[3] 450	500	600	mV
$I_{OZ}$	off-state output current	single-ended	-	-	10	$\mu$ A
$t_r$	rise time	20 % to 80 %	[4] 75	-	180	ps
$t_f$	fall time	80 % to 20 %	[4] 75	-	180	ps
$t_{sk}$	skew time	intra-pair	[5] -	-	10	ps
		inter-pair	[6] -	-	250	ps
$t_{jit}$	jitter time	jitter contribution	[7] -	-	7.4	ps

[1]  $V_{TT}$  is the DC termination voltage in the DVI or HDMI sink.  $V_{TT}$  is nominally 3.3 V. Termination resistance is nominally 50  $\Omega$ .

[2] The open-drain output pulls down from  $V_{TT}$ .

[3] Swing down from TMDS termination voltage ( $3.3 \text{ V} \pm 10 \%$ ).

[4] Maximum rise/fall time at 2.25 Gbit/s = 444 ps. 400 ps = 444 ps – 15 %.

[5] This differential skew budget is in addition to the skew presented between IN\_D+ and IN\_D– paired input pins.

[6] This lane-to-lane skew budget is in addition to skew between differential input pairs.

[7] Jitter budget for differential signals as they pass through the level shifter. 7.4 ps = 0.02 UI at 1.65 Gbit/s.

### 9.3 HPD\_SINK input, HPD\_SOURCE\_N output

Table 9. HPD characteristics

Symbol	Parameter	Conditions	Min	Typ	Max	Unit
V <sub>IH</sub>	HIGH-level input voltage	HPD_SINK	[1] 2.0	5.0	5.3	V
V <sub>IL</sub>	LOW-level input voltage	HPD_SINK	0	-	0.8	V
I <sub>LI</sub>	input leakage current	HPD_SINK	[2] -	-	10	μA
V <sub>OH</sub>	HIGH-level output voltage	HPD_SOURCE_N; I <sub>OH</sub> = 100 μA; HPD_SINK = LOW	0.7	-	1.1	V
V <sub>OL</sub>	LOW-level output voltage	HPD_SOURCE_N; I <sub>OL</sub> = 100 μA; HPD_SINK = HIGH	0	-	0.2	V
t <sub>PD</sub>	propagation delay	from HPD_SINK to HPD_SOURCE_N; 50 % to 50 %; C <sub>L</sub> = 10 pF	[3] -	-	200	ns
t <sub>t</sub>	transition time	HPD_SOURCE_N rise/fall; 10 % to 90 %; C <sub>L</sub> = 10 pF	[4] 1	-	20	ns
R <sub>pd</sub>	pull-down resistance	HPD_SINK input pull-down resistor	[5] 100	200	300	kΩ

- [1] Low-speed input changes state on cable plug/unplug.
- [2] Measured with HPD\_SINK at V<sub>IH</sub> maximum and V<sub>IL</sub> minimum.
- [3] Time from HPD\_SINK changing state to HPD\_SOURCE\_N changing state. Includes HPD\_SOURCE\_N rise/fall time.
- [4] Time required to transition from V<sub>OH</sub> to V<sub>OL</sub> or from V<sub>OL</sub> to V<sub>OH</sub>.
- [5] Guarantees HPD\_SINK is LOW when no display is plugged in.

### 9.4 OE\_N and DDC\_EN inputs

Table 10. OE\_N and DDC\_EN input characteristics

Symbol	Parameter	Conditions	Min	Typ	Max	Unit
V <sub>IH</sub>	HIGH-level input voltage		2.0	-	-	V
V <sub>IL</sub>	LOW-level input voltage		-	-	0.8	V
I <sub>LI</sub>	input leakage current	OE_N pin	[1] -	-	10	μA

- [1] Measured with input at V<sub>IH</sub> maximum and V<sub>IL</sub> minimum.

### 9.5 DDC characteristics

Table 11. DDC characteristics

Symbol	Parameter	Conditions	Min	Typ	Max	Unit
f <sub>clk</sub>	clock frequency	SCL_SOURCE, SDA_SOURCE, SCL_SINK, SDA_SINK	-	-	400	kHz
<b>ON state (DDC_EN = HIGH and HPD_SINK = HIGH)</b>						
R <sub>ON</sub>	ON resistance	pass gate in ON state; I <sub>O</sub> = 15 mA; V <sub>O</sub> = 0.4 V	-	7	30	Ω
V <sub>O(sw)</sub>	switch output voltage	SOURCE side; V <sub>I</sub> = 3.3 V; I <sub>O</sub> = -100 μA	1.8	2.1	2.4	V
		SINK side; V <sub>I</sub> = 5.0 V; I <sub>O</sub> = -100 μA	1.8	2.1	2.4	V
C <sub>io</sub>	input/output capacitance	V <sub>I</sub> = 3.3 V; I <sub>O</sub> = -100 μA	-	5	10	pF
<b>OFF state (DDC_EN = LOW)</b>						
I <sub>LI</sub>	input leakage current	SOURCE side; 0 V < V <sub>I</sub> < 3.3 V	-1	-	+1	μA
		SINK side; 0 V < V <sub>I</sub> < 5.0 V	-1	-	+1	μA
C <sub>io</sub>	input/output capacitance	V <sub>I</sub> = 3.3 V; I <sub>O</sub> = -100 μA	-	1	5	pF

### 10. Package outline

**HWQFN48R: plastic thermal enhanced very very thin quad flat package; no leads**  
**48 terminals; resin based; body 7 x 7 x 0.7 mm**

SOT1031-2

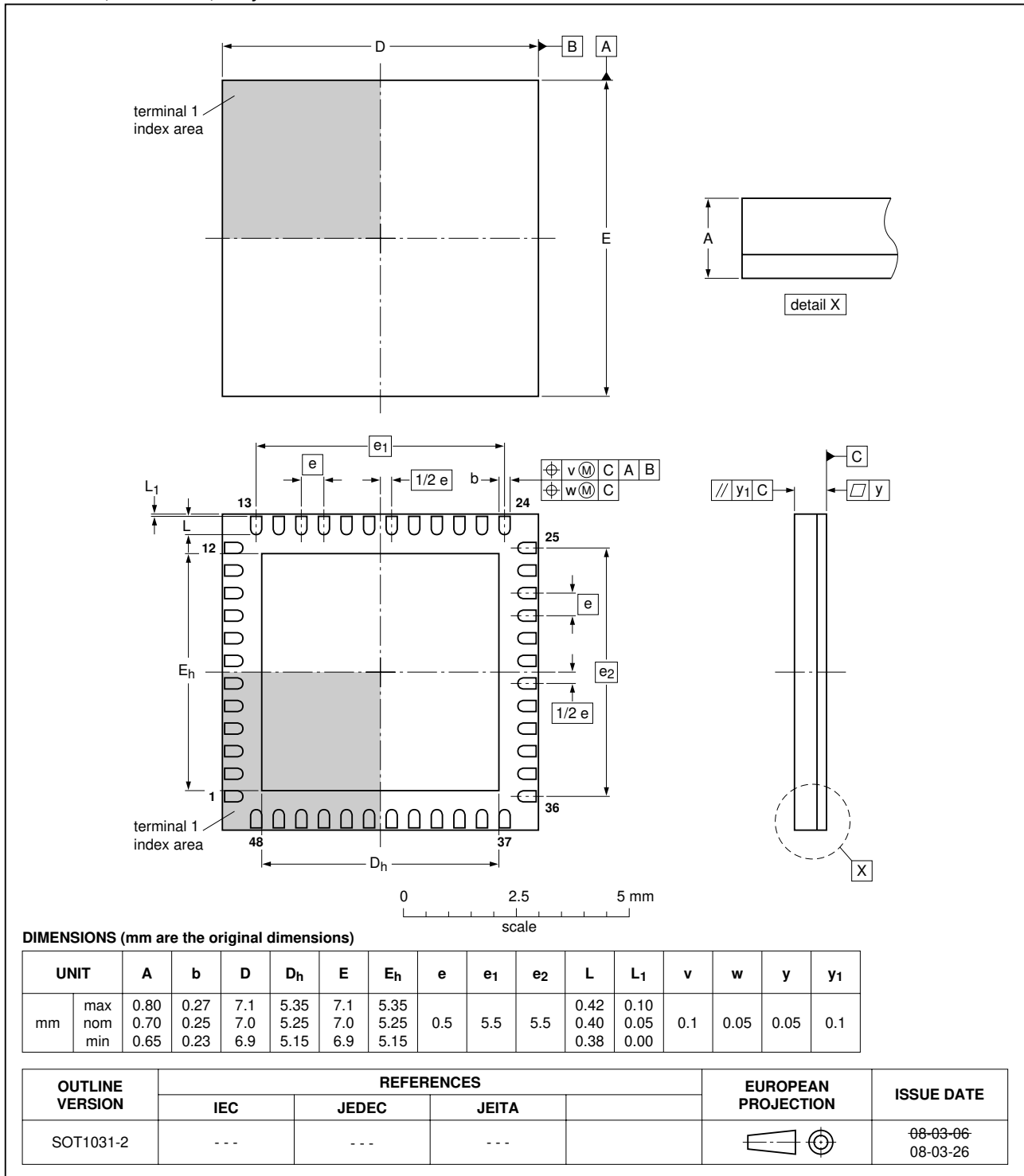

Fig 5. Package outline SOT1031-2 (HWQFN48R)

HWQFN48: plastic thermal enhanced very very thin quad flat package; no leads;  
48 terminals; body 7 x 7 x 0.65 mm

SOT1074-1

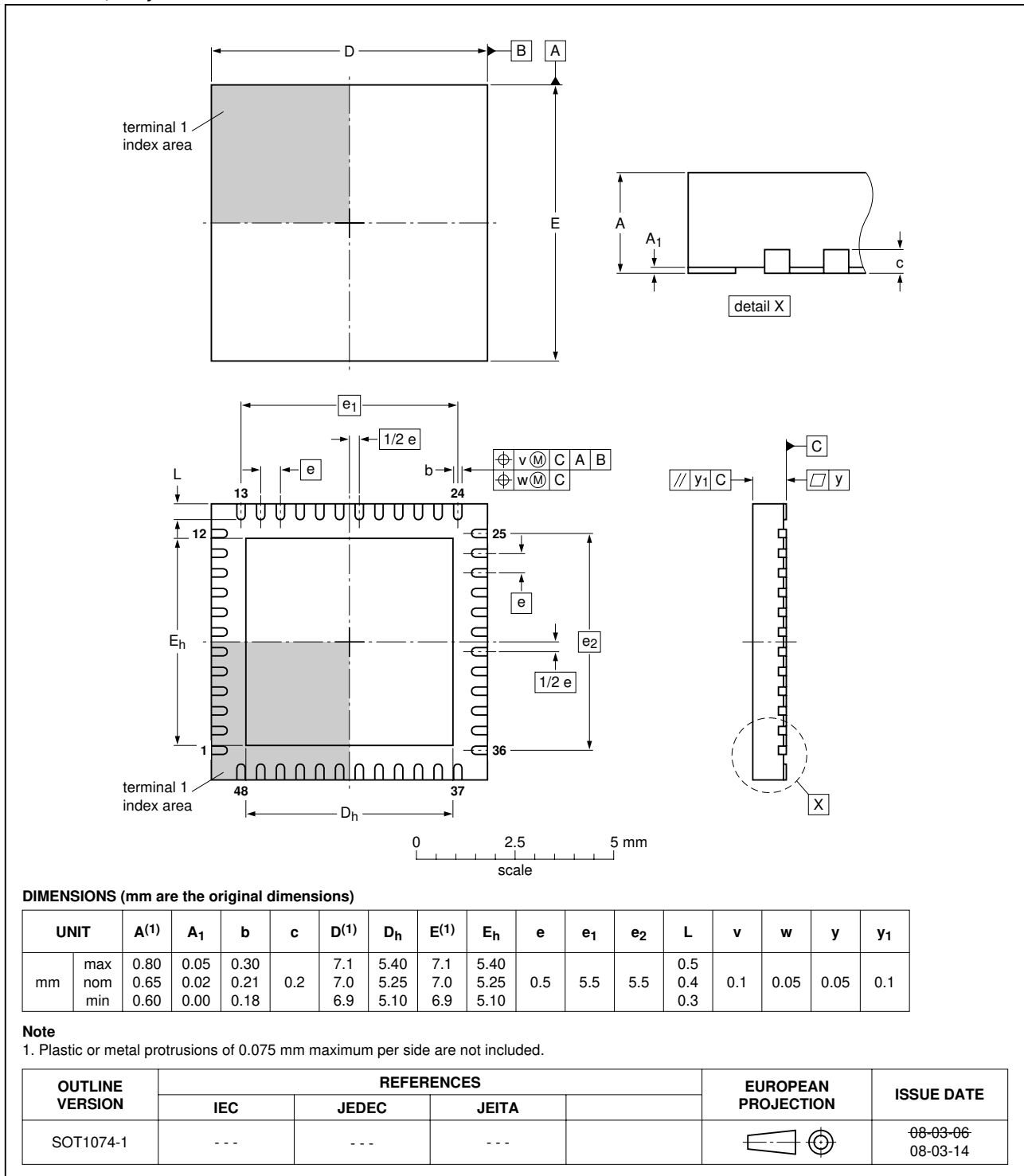

Fig 6. Package outline SOT1074-1 (HWQFN48)



## 11. Soldering of SMD packages

This text provides a very brief insight into a complex technology. A more in-depth account of soldering ICs can be found in Application Note *AN10365 "Surface mount reflow soldering description"*.

### 11.1 Introduction to soldering

Soldering is one of the most common methods through which packages are attached to Printed Circuit Boards (PCBs), to form electrical circuits. The soldered joint provides both the mechanical and the electrical connection. There is no single soldering method that is ideal for all IC packages. Wave soldering is often preferred when through-hole and Surface Mount Devices (SMDs) are mixed on one printed wiring board; however, it is not suitable for fine pitch SMDs. Reflow soldering is ideal for the small pitches and high densities that come with increased miniaturization.

### 11.2 Wave and reflow soldering

Wave soldering is a joining technology in which the joints are made by solder coming from a standing wave of liquid solder. The wave soldering process is suitable for the following:

- Through-hole components
- Leaded or leadless SMDs, which are glued to the surface of the printed circuit board

Not all SMDs can be wave soldered. Packages with solder balls, and some leadless packages which have solder lands underneath the body, cannot be wave soldered. Also, leaded SMDs with leads having a pitch smaller than ~0.6 mm cannot be wave soldered, due to an increased probability of bridging.

The reflow soldering process involves applying solder paste to a board, followed by component placement and exposure to a temperature profile. Leaded packages, packages with solder balls, and leadless packages are all reflow solderable.

Key characteristics in both wave and reflow soldering are:

- Board specifications, including the board finish, solder masks and vias
- Package footprints, including solder thieves and orientation
- The moisture sensitivity level of the packages
- Package placement
- Inspection and repair
- Lead-free soldering versus SnPb soldering

### 11.3 Wave soldering

Key characteristics in wave soldering are:

- Process issues, such as application of adhesive and flux, clinching of leads, board transport, the solder wave parameters, and the time during which components are exposed to the wave
- Solder bath specifications, including temperature and impurities

### 11.4 Reflow soldering

Key characteristics in reflow soldering are:

- Lead-free versus SnPb soldering; note that a lead-free reflow process usually leads to higher minimum peak temperatures (see [Figure 7](#)) than a SnPb process, thus reducing the process window
- Solder paste printing issues including smearing, release, and adjusting the process window for a mix of large and small components on one board
- Reflow temperature profile; this profile includes preheat, reflow (in which the board is heated to the peak temperature) and cooling down. It is imperative that the peak temperature is high enough for the solder to make reliable solder joints (a solder paste characteristic). In addition, the peak temperature must be low enough that the packages and/or boards are not damaged. The peak temperature of the package depends on package thickness and volume and is classified in accordance with [Table 12](#) and [13](#)

**Table 12. SnPb eutectic process (from J-STD-020C)**

Package thickness (mm)	Package reflow temperature (°C)	
	Volume (mm <sup>3</sup> )	
	< 350	≥ 350
< 2.5	235	220
≥ 2.5	220	220

**Table 13. Lead-free process (from J-STD-020C)**

Package thickness (mm)	Package reflow temperature (°C)		
	Volume (mm <sup>3</sup> )		
	< 350	350 to 2000	> 2000
< 1.6	260	260	260
1.6 to 2.5	260	250	245
> 2.5	250	245	245

Moisture sensitivity precautions, as indicated on the packing, must be respected at all times.

Studies have shown that small packages reach higher temperatures during reflow soldering, see [Figure 7](#).

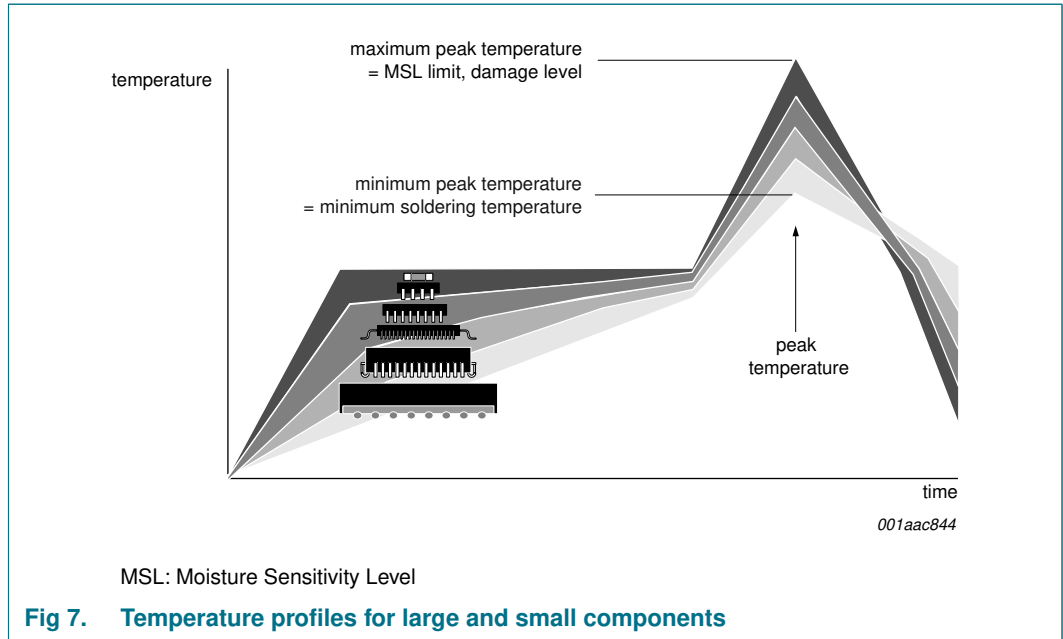

For further information on temperature profiles, refer to Application Note AN10365 “Surface mount reflow soldering description”.

## 12. Abbreviations

**Table 14. Abbreviations**

Acronym	Description
CDM	Charged-Device Model
CEC	Consumer Electronics Control
DDC	Data Display Channel
DVI	Digital Visual Interface
EMI	ElectroMagnetic Interference
ESD	ElectroStatic Discharge
HBM	Human Body Model
HDMI	High-Definition Multimedia Interface
HPD	Hot Plug Detect
I <sup>2</sup> C-bus	Inter-Integrated Circuit bus
I/O	Input/Output
NMOS	Negative-channel Metal-Oxide Semiconductor
TMDS	Transition Minimized Differential Signaling
VESA	Video Electronics Standards Association

## 13. Revision history

Table 15. Revision history

Document ID	Release date	Data sheet status	Change notice	Supersedes
PTN3300A_1	20080630	Product data sheet	-	-

## 14. Legal information

### 14.1 Data sheet status

Document status <sup>[1][2]</sup>	Product status <sup>[3]</sup>	Definition
Objective [short] data sheet	Development	This document contains data from the objective specification for product development.
Preliminary [short] data sheet	Qualification	This document contains data from the preliminary specification.
Product [short] data sheet	Production	This document contains the product specification.

[1] Please consult the most recently issued document before initiating or completing a design.

[2] The term 'short data sheet' is explained in section "Definitions".

[3] The product status of device(s) described in this document may have changed since this document was published and may differ in case of multiple devices. The latest product status information is available on the Internet at URL <http://www.nxp.com>.

### 14.2 Definitions

**Draft** — The document is a draft version only. The content is still under internal review and subject to formal approval, which may result in modifications or additions. NXP Semiconductors does not give any representations or warranties as to the accuracy or completeness of information included herein and shall have no liability for the consequences of use of such information.

**Short data sheet** — A short data sheet is an extract from a full data sheet with the same product type number(s) and title. A short data sheet is intended for quick reference only and should not be relied upon to contain detailed and full information. For detailed and full information see the relevant full data sheet, which is available on request via the local NXP Semiconductors sales office. In case of any inconsistency or conflict with the short data sheet, the full data sheet shall prevail.

### 14.3 Disclaimers

**General** — Information in this document is believed to be accurate and reliable. However, NXP Semiconductors does not give any representations or warranties, expressed or implied, as to the accuracy or completeness of such information and shall have no liability for the consequences of use of such information.

**Right to make changes** — NXP Semiconductors reserves the right to make changes to information published in this document, including without limitation specifications and product descriptions, at any time and without notice. This document supersedes and replaces all information supplied prior to the publication hereof.

**Suitability for use** — NXP Semiconductors products are not designed, authorized or warranted to be suitable for use in medical, military, aircraft, space or life support equipment, nor in applications where failure or

malfunction of an NXP Semiconductors product can reasonably be expected to result in personal injury, death or severe property or environmental damage. NXP Semiconductors accepts no liability for inclusion and/or use of NXP Semiconductors products in such equipment or applications and therefore such inclusion and/or use is at the customer's own risk.

**Applications** — Applications that are described herein for any of these products are for illustrative purposes only. NXP Semiconductors makes no representation or warranty that such applications will be suitable for the specified use without further testing or modification.

**Limiting values** — Stress above one or more limiting values (as defined in the Absolute Maximum Ratings System of IEC 60134) may cause permanent damage to the device. Limiting values are stress ratings only and operation of the device at these or any other conditions above those given in the Characteristics sections of this document is not implied. Exposure to limiting values for extended periods may affect device reliability.

**Terms and conditions of sale** — NXP Semiconductors products are sold subject to the general terms and conditions of commercial sale, as published at <http://www.nxp.com/profile/terms>, including those pertaining to warranty, intellectual property rights infringement and limitation of liability, unless explicitly otherwise agreed to in writing by NXP Semiconductors. In case of any inconsistency or conflict between information in this document and such terms and conditions, the latter will prevail.

**No offer to sell or license** — Nothing in this document may be interpreted or construed as an offer to sell products that is open for acceptance or the grant, conveyance or implication of any license under any copyrights, patents or other industrial or intellectual property rights.

### 14.4 Trademarks

Notice: All referenced brands, product names, service names and trademarks are the property of their respective owners.

## 15. Contact information

For more information, please visit: <http://www.nxp.com>

For sales office addresses, please send an email to: [salesaddresses@nxp.com](mailto:salesaddresses@nxp.com)



## 16. Contents

<b>1</b>	<b>General description</b> . . . . .	<b>1</b>
<b>2</b>	<b>Features</b> . . . . .	<b>3</b>
2.1	High-speed TMDS level shifting . . . . .	3
2.2	DDC level shifting . . . . .	3
2.3	HPD level shifting . . . . .	3
2.4	General . . . . .	3
<b>3</b>	<b>Ordering information</b> . . . . .	<b>3</b>
<b>4</b>	<b>Functional diagram</b> . . . . .	<b>4</b>
<b>5</b>	<b>Pinning information</b> . . . . .	<b>5</b>
5.1	Pinning . . . . .	5
5.2	Pin description . . . . .	7
<b>6</b>	<b>Functional description</b> . . . . .	<b>9</b>
6.1	Flexible and power-efficient enable and disable features. . . . .	9
6.1.1	Hot plug detect with power-saving feature . . . . .	9
6.1.2	Output Enable function (OE_N) . . . . .	10
6.1.3	DDC channel enable function (DDC_EN) . . . . .	10
6.1.4	Enable/disable truth table . . . . .	10
6.2	Analog current reference . . . . .	11
6.3	Backdrive current protection . . . . .	11
<b>7</b>	<b>Limiting values</b> . . . . .	<b>12</b>
<b>8</b>	<b>Recommended operating conditions</b> . . . . .	<b>12</b>
8.1	Current consumption . . . . .	12
<b>9</b>	<b>Characteristics</b> . . . . .	<b>13</b>
9.1	Differential inputs . . . . .	13
9.2	Differential outputs . . . . .	14
9.3	HPD_SINK input, HPD_SOURCE_N output . . . . .	15
9.4	OE_N and DDC_EN inputs . . . . .	15
9.5	DDC characteristics . . . . .	15
<b>10</b>	<b>Package outline</b> . . . . .	<b>16</b>
<b>11</b>	<b>Soldering of SMD packages</b> . . . . .	<b>18</b>
11.1	Introduction to soldering . . . . .	18
11.2	Wave and reflow soldering . . . . .	18
11.3	Wave soldering . . . . .	18
11.4	Reflow soldering . . . . .	19
<b>12</b>	<b>Abbreviations</b> . . . . .	<b>20</b>
<b>13</b>	<b>Revision history</b> . . . . .	<b>21</b>
<b>14</b>	<b>Legal information</b> . . . . .	<b>22</b>
14.1	Data sheet status . . . . .	22
14.2	Definitions . . . . .	22
14.3	Disclaimers . . . . .	22
14.4	Trademarks . . . . .	22
<b>15</b>	<b>Contact information</b> . . . . .	<b>22</b>
<b>16</b>	<b>Contents</b> . . . . .	<b>23</b>

Please be aware that important notices concerning this document and the product(s) described herein, have been included in section 'Legal information'.

founded by

**PHILIPS**

© NXP B.V. 2008.

All rights reserved.

For more information, please visit: <http://www.nxp.com>

For sales office addresses, please send an email to: [salesaddresses@nxp.com](mailto:salesaddresses@nxp.com)

Date of release: 30 June 2008

Document identifier: PTN3300A\_1