



Chipsmall Limited consists of a professional team with an average of over 10 year of expertise in the distribution of electronic components. Based in Hongkong, we have already established firm and mutual-benefit business relationships with customers from,Europe,America and south Asia,supplying obsolete and hard-to-find components to meet their specific needs.

With the principle of "Quality Parts,Customers Priority,Honest Operation,and Considerate Service",our business mainly focus on the distribution of electronic components. Line cards we deal with include Microchip,ALPS,ROHM,Xilinx,Pulse,ON,Everlight and Freescale. Main products comprise IC,Modules,Potentiometer,IC Socket,Relay,Connector.Our parts cover such applications as commercial,industrial, and automotives areas.

We are looking forward to setting up business relationship with you and hope to provide you with the best service and solution. Let us make a better world for our industry!



## Contact us

Tel: +86-755-8981 8866 Fax: +86-755-8427 6832

Email & Skype: info@chipsmall.com Web: www.chipsmall.com

Address: A1208, Overseas Decoration Building, #122 Zhenhua RD., Futian, Shenzhen, China



# PTN3381B

Enhanced performance HDMI/DVI level shifter with voltage regulator, dongle detect support and active DDC buffer

Rev. 2 — 15 October 2010

Product data sheet

## 1. General description

---

The PTN3381B is a high-speed level shifter device which converts four lanes of low-swing AC-coupled differential input signals to DVI v1.0 and HDMI v1.3a compliant open-drain current-steering differential output signals, up to 1.65 Gbit/s per lane. Each of these lanes provides a level-shifting differential buffer to translate from low-swing AC-coupled differential signaling on the source side, to TMDS-type DC-coupled differential current-mode signaling terminated into  $50\ \Omega$  to 3.3 V on the sink side. Additionally, the PTN3381B provides a single-ended active buffer for voltage translation of the HPD signal from 5 V on the sink side to 3.3 V on the source side and provides a channel with active buffering and level shifting of the DDC channel (consisting of a clock and a data line) between 3.3 V source-side and 5 V sink-side. The DDC channel is implemented using active I<sup>2</sup>C-bus buffer technology providing capacitive isolation, redriving and level shifting as well as disablement (isolation between source and sink) of the clock and data lines.

To provide the highest level of integration in external adapter (or: dongle) applications, PTN3381B includes an onboard 5 V DC regulator. Its output is designed to provide the required 5 V power supply to the DVI or HDMI connector, thereby eliminating the need for a separate external regulator. The on-board regulator needs only two external capacitors to operate, and its output is active whenever a valid 3.3 V is applied to the PTN3381B V<sub>DD</sub> pins.

The low-swing AC-coupled differential input signals to the PTN3381B typically come from a display source with multi-mode I/O, which supports multiple display standards, e.g., DisplayPort, HDMI and DVI. While the input differential signals are configured to carry DVI or HDMI coded data, they do not comply with the electrical requirements of the DVI v1.0 or HDMI v1.3a specification. By using PTN3381B, chip set vendors are able to implement such reconfigurable I/Os on multi-mode display source devices, allowing the support of multiple display standards while keeping the number of chip set I/O pins low. See [Figure 1](#).

The PTN3381B main high-speed differential lanes feature low-swing self-biasing differential inputs which are compliant to the electrical specifications of *DisplayPort Standard v1.1* and/or *PCI Express Standard v1.1*, and open-drain current-steering differential outputs compliant to DVI v1.0 and HDMI v1.3a electrical specifications. The I<sup>2</sup>C-bus channel actively buffers as well as level-translates the DDC signals for optimal capacitive isolation. Its I<sup>2</sup>C-bus control block also provides for optional software HDMI dongle detect by issuing a predetermined code sequence upon a read command to an I<sup>2</sup>C-bus specified address. The PTN3381B also supports power-saving modes in order to minimize current consumption when no display is active or connected.

The PTN3381B is a fully featured HDMI as well as DVI level shifter. It is functionally equivalent to PTN3361B but provides an onboard 5 V regulator.



PTN3381B is powered from a single 3.3 V power supply consuming a small amount of power (100 mW typical without load at 5 V regulator output) and is offered in a 48-terminal HVQFN48 package.

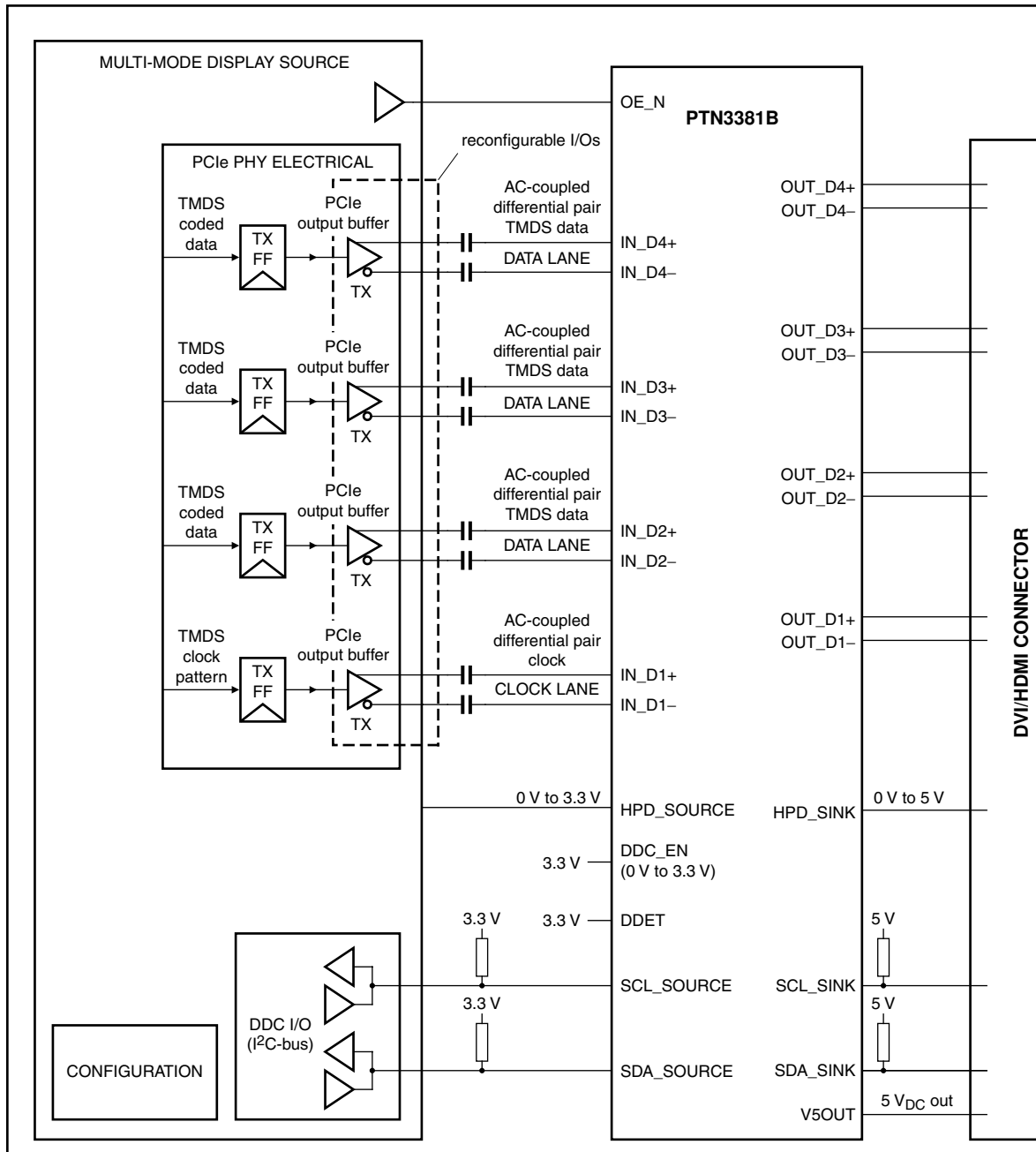

002aae076

**Remark:** TMDS clock and data lanes can be assigned arbitrarily and interchangeably to D[4:1].

**Fig 1. Typical application system diagram**

## 2. Features and benefits

### 2.1 High-speed TMDS level shifting

- Converts four lanes of low-swing AC-coupled differential input signals to DVI v1.0 and HDMI v1.3a compliant open-drain current-steering differential output signals
- Pin-programmable pre-emphasis feature
- TMDS level shifting operation up to 1.65 Gbit/s per lane (165 MHz character clock)
- TMDS level shifting operation up to 2.25 Gbit/s per lane (225 MHz character clock) using pre-emphasis feature
- Integrated 50  $\Omega$  termination resistors for self-biasing differential inputs
- Back-current safe outputs to disallow current when device power is off and monitor is on
- Disable feature to turn off TMDS inputs and outputs and to enter low-power state

### 2.2 DDC level shifting

- Integrated DDC buffering and level shifting (3.3 V source to 5 V sink side)
- Rise time accelerator on sink-side DDC ports
- 0 Hz to 400 kHz I<sup>2</sup>C-bus clock frequency
- Back-power safe sink-side terminals to disallow backdrive current when power is off or when DDC is not enabled

### 2.3 HDMI dongle detect support

- Incorporates I<sup>2</sup>C slave ROM
- Responds to DDC read to address 81h with predetermined byte sequence
- Feature enabled by pin DDET (must be enabled for correct operation in accordance with DisplayPort interoperability guideline)

### 2.4 HPD level shifting

- HPD non-inverting level shift from 0 V on the sink side to 0 V on the source side, or from 5 V on the sink side to 3.3 V on the source side
- Integrated 200 k $\Omega$  pull-down resistor on HPD sink input guarantees 'input LOW' when no display is plugged in
- Back-power safe design on HPD\_SINK to disallow backdrive current when power is off

### 2.5 5 V DC voltage regulator

- Generates 5 V for the DVI/HDMI connector from the 3.3 V DP\_PWR pin supplied by the DisplayPort connector
- Supports up to 75 mA of load current with an accuracy of  $\pm 300$  mV
- Only two external capacitors required
- Eliminates need for an external 5 V regulator in dongle applications
- Back drive protection on 5 V output
- Short-circuit protection
- Overcurrent protection

## 2.6 General

- Power supply 3.3 V  $\pm$  10 %
- ESD resilience to 4 kV HBM, 1 kV CDM
- Support for optional HDMI dongle detection via DDC/I<sup>2</sup>C-bus channel
- Power-saving modes (using output enable)
- Back-current-safe design on all sink-side main link, DDC and HPD terminals
- Transparent operation: no re-timing or software configuration required

## 3. Applications

- DisplayPort to HDMI adapters
- DisplayPort to DVI adapters required to drive long cables

## 4. Ordering information

Table 1. Ordering information

Type number	Package		Version
	Name	Description	
PTN3381BBS	HVQFN48	plastic thermal enhanced very thin quad flat package; no leads; 48 terminals; body 7 × 7 × 0.85 mm	SOT619-1

**5. Functional diagram**

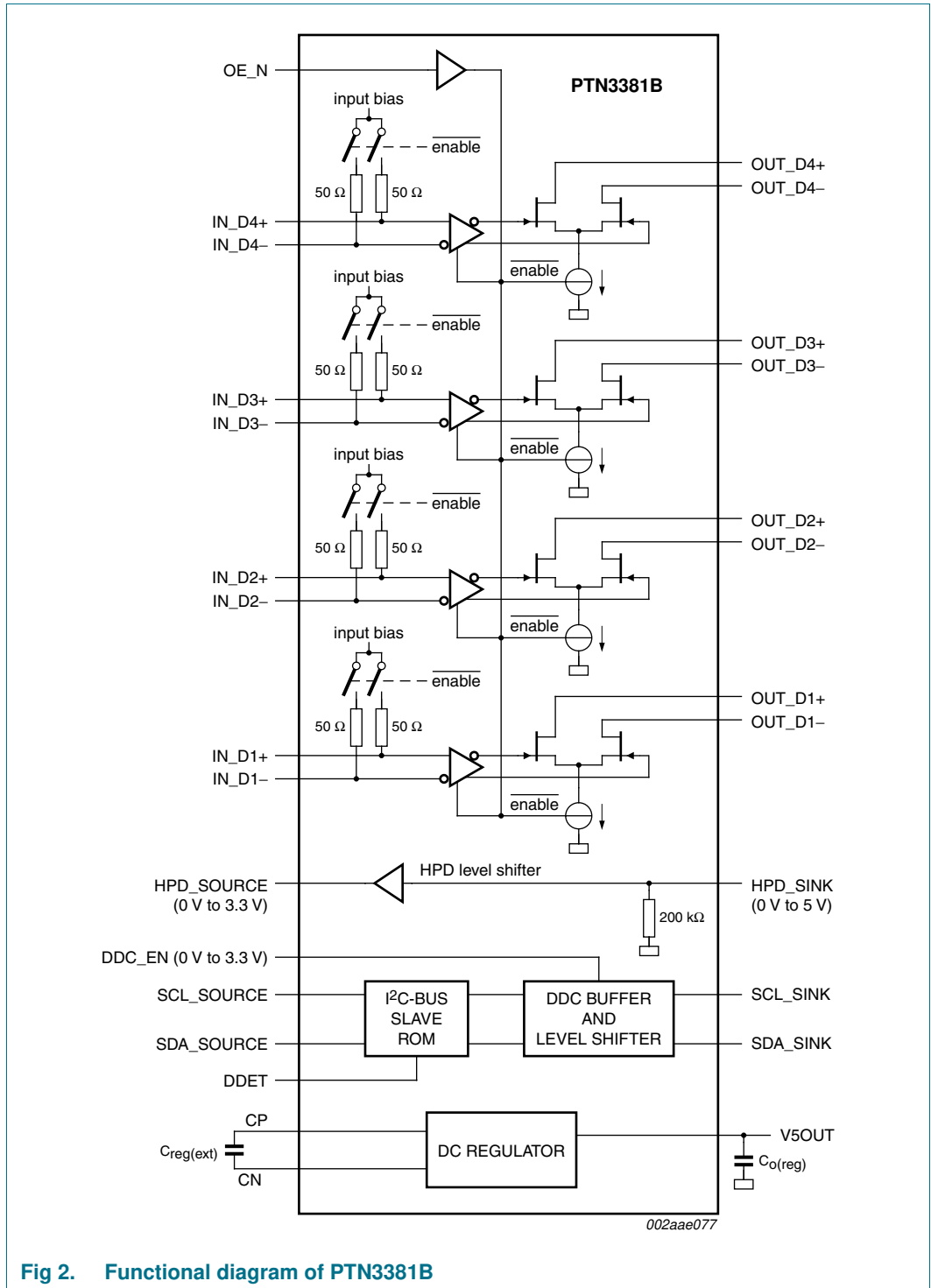

**Fig 2. Functional diagram of PTN3381B**

## 6. Pinning information

### 6.1 Pinning

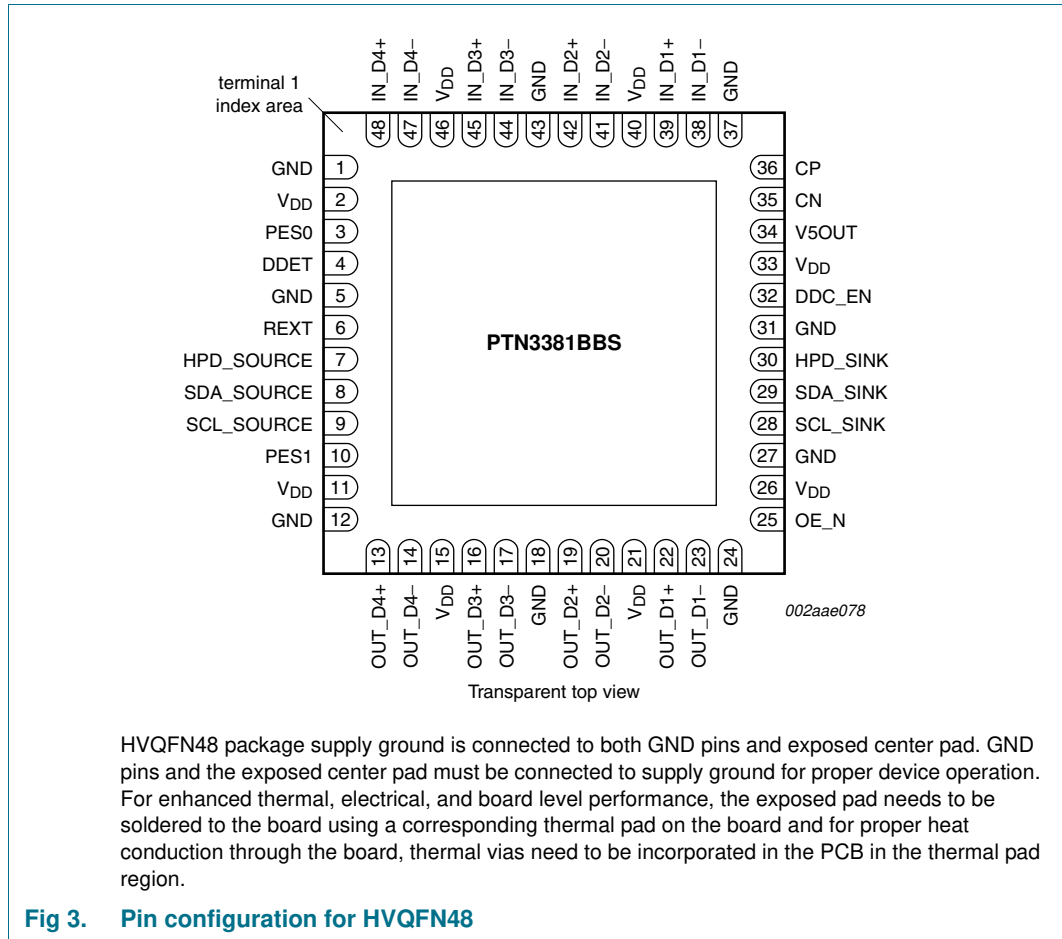

### 6.2 Pin description

Table 2. Pin description

Symbol	Pin	Type	Description
<b>OE_N, IN_Dx and OUT_Dx signals</b>			
OE_N	25	3.3 V low-voltage CMOS single-ended input	Output Enable and power saving function for high-speed differential level shifter path. When OE_N = HIGH: IN_Dx termination = high-impedance OUT_Dx outputs = high-impedance; zero output current When OE_N = LOW: IN_Dx termination = 50 Ω OUT_Dx outputs = active
IN_D4+	48	Self-biasing differential input	Low-swing differential input from display source with PCI Express electrical signalling. IN_D4+ makes a differential pair with IN_D4-. The input to this pin must be AC coupled externally.

Table 2. Pin description ...continued

Symbol	Pin	Type	Description
IN_D4-	47	Self-biasing differential input	Low-swing differential input from display source with PCI Express electrical signalling. IN_D4- makes a differential pair with IN_D4+. The input to this pin must be AC coupled externally.
IN_D3+	45	Self-biasing differential input	Low-swing differential input from display source with PCI Express electrical signalling. IN_D3+ makes a differential pair with IN_D3-. The input to this pin must be AC coupled externally.
IN_D3-	44	Self-biasing differential input	Low-swing differential input from display source with PCI Express electrical signalling. IN_D3- makes a differential pair with IN_D3+. The input to this pin must be AC coupled externally.
IN_D2+	42	Self-biasing differential input	Low-swing differential input from display source with PCI Express electrical signalling. IN_D2+ makes a differential pair with IN_D2-. The input to this pin must be AC coupled externally.
IN_D2-	41	Self-biasing differential input	Low-swing differential input from display source with PCI Express electrical signalling. IN_D2- makes a differential pair with IN_D2+. The input to this pin must be AC coupled externally.
IN_D1+	39	Self-biasing differential input	Low-swing differential input from display source with PCI Express electrical signalling. IN_D1+ makes a differential pair with IN_D1-. The input to this pin must be AC coupled externally.
IN_D1-	38	Self-biasing differential input	Low-swing differential input from display source with PCI Express electrical signalling. IN_D1- makes a differential pair with IN_D1+. The input to this pin must be AC coupled externally.
OUT_D4+	13	TMDS differential output	HDMI compliant TMDS output. OUT_D4+ makes a differential pair with OUT_D4-. OUT_D4+ is in phase with IN_D4+.
OUT_D4-	14	TMDS differential output	HDMI compliant TMDS output. OUT_D4- makes a differential pair with OUT_D4+. OUT_D4- is in phase with IN_D4-.
OUT_D3+	16	TMDS differential output	HDMI compliant TMDS output. OUT_D3+ makes a differential pair with OUT_D3-. OUT_D3+ is in phase with IN_D3+.
OUT_D3-	17	TMDS differential output	HDMI compliant TMDS output. OUT_D3- makes a differential pair with OUT_D3+. OUT_D3- is in phase with IN_D3-.
OUT_D2+	19	TMDS differential output	HDMI compliant TMDS output. OUT_D2+ makes a differential pair with OUT_D2-. OUT_D2+ is in phase with IN_D2+.
OUT_D2-	20	TMDS differential output	HDMI compliant TMDS output. OUT_D2- makes a differential pair with OUT_D2+. OUT_D2- is in phase with IN_D2-.
OUT_D1+	22	TMDS differential output	HDMI compliant TMDS output. OUT_D1+ makes a differential pair with OUT_D1-. OUT_D1+ is in phase with IN_D1+.
OUT_D1-	23	TMDS differential output	HDMI compliant TMDS output. OUT_D1- makes a differential pair with OUT_D1+. OUT_D1- is in phase with IN_D1-.
<b>HPD and DDC signals</b>			
HPD_SINK	30	5 V CMOS single-ended input	0 V to 5 V (nominal) input signal. This signal comes from the DVI or HDMI sink. A HIGH value indicates that the sink is connected; a LOW value indicates that the sink is disconnected. HPD_SINK is pulled down by an integrated 200 kΩ pull-down resistor.
HPD_SOURCE	7	3.3 V CMOS single-ended output	0 V to 3.3 V (nominal) output signal. This is level-shifted version of the HPD_SINK signal.
SCL_SOURCE	9	single-ended 3.3 V open-drain DDC I/O	3.3 V source-side DDC clock I/O. Pulled up by external termination to 3.3 V.
SDA_SOURCE	8	single-ended 3.3 V open-drain DDC I/O	3.3 V source-side DDC data I/O. Pulled up by external termination to 3.3 V.



Table 2. Pin description ...continued

Symbol	Pin	Type	Description
SCL_SINK	28	single-ended 5 V open-drain DDC I/O	5 V sink-side DDC clock I/O. Pulled up by external termination to 5 V. Provides rise time acceleration for LOW-to-HIGH transitions.
SDA_SINK	29	single-ended 5 V open-drain DDC I/O	5 V sink-side DDC data I/O. Pulled up by external termination to 5 V. Provides rise time acceleration for LOW-to-HIGH transitions.
DDC_EN	32	3.3 V CMOS input	Enables the DDC buffer and level shifter. When DDC_EN = LOW, buffer/level shifter is disabled. When DDC_EN = HIGH, buffer and level shifter are enabled.

#### Supply and ground

V <sub>DD</sub>	2, 11, 15, 21, 26, 33, 40, 46	3.3 V DC supply	Supply voltage; 3.3 V ± 10 %.
GND <sup>[1]</sup>	1, 5, 12, 18, 24, 27, 31, 37, 43	ground	Supply ground. All GND pins must be connected to ground for proper operation.

#### Feature control signals

REXT	6	analog I/O	Current sense port used to provide an accurate current reference for the differential outputs OUT_Dx. For best output voltage swing accuracy, use of a 10 kΩ resistor (1 % tolerance) from this terminal to GND is recommended. May also be left open-circuit or tied to either V <sub>DD</sub> or GND. See <a href="#">Section 7.2</a> for details.
DDET	4	3.3 V input	Dongle detect enable input. When HIGH, the dongle detect function via I <sup>2</sup> C is active. When LOW, the dongle detect function will not respond to an I <sup>2</sup> C-bus command. Must be tied to GND or V <sub>DD</sub> either directly or via a resistor. Note that this pin may not be left open-circuit. When used in an HDMI dongle, this pin <b>must</b> be tied HIGH for correct operation in accordance with DisplayPort interoperability guidelines. When used in a DVI dongle, this pin <b>must</b> be tied LOW.
PES1	10	3.3 V CMOS input	Programming pins to activate the pre-emphasis feature of the TMDS differential outputs. See <a href="#">Section 7.3</a> for details. Must be tied either to GND or V <sub>DD</sub> either directly or via a resistor (< 1 kΩ). To disable pre-emphasis, connect both to GND (PES[1:0] = 00b). PES[1:0] = 11b is reserved for testing purposes and should not be used in normal application. Note that these pins may not be left open-circuit.
PES0	3	3.3 V CMOS input	

#### Voltage regulator terminals

CP	36	analog high-voltage	Positive terminal for the voltage regulator external capacitor. <sup>[2]</sup>
CN	35	analog high-voltage	Negative terminal for the voltage regulator external capacitor. <sup>[2]</sup>
V5OUT	34	power output	5 V regulated output from the integrated voltage regulator. <sup>[2]</sup>

[1] HVQFN48 package supply ground is connected to both GND pins and exposed center pad. GND pins and the exposed center pad must be connected to supply ground for proper device operation. For enhanced thermal, electrical, and board level performance, the exposed pad needs to be soldered to the board using a corresponding thermal pad on the board and for proper heat conduction through the board, thermal vias need to be incorporated in the PCB in the thermal pad region.

[2] A ceramic capacitor with ESR < 100 mΩ is recommended and should be placed close to the pin(s).

## 7. Functional description

Refer to [Figure 2 “Functional diagram of PTN3381B”](#).

The PTN3381B level shifts four lanes of low-swing AC-coupled differential input signals to DVI and HDMI compliant open-drain current-steering differential output signals, up to 1.65 Gbit/s per lane. Speed of operation and cable length drive may be extended (by using the programmable pre-emphasis feature) to up to 2.25 Gbit/s per lane. It has integrated 50  $\Omega$  termination resistors for AC-coupled differential input signals. An enable signal OE\_N can be used to turn off the TMDS inputs and outputs, thereby minimizing power consumption. The TMDS outputs are back-power safe to disallow current flow from a powered sink while the PTN3381B is unpowered.

The PTN3381B's DDC channel provides active level shifting and buffering, allowing 3.3 V source-side termination and 5 V sink-side termination. The sink-side DDC ports are equipped with a rise time accelerator enabling drive of long cables or high bus capacitance. This enables the system designer to isolate bus capacitance to meet HDMI DDC version 1.3a distance specification. Furthermore, the DDC channel is augmented with an I<sup>2</sup>C-bus slave ROM device that provides optional HDMI dongle detect response, which can be enabled by dongle detect signal DDET. The PTN3381B offers back-power safe sink-side I/Os to disallow backdrive current from the DDC clock and data lines when power is off or when DDC is not enabled. An enable signal DCC\_EN enables the DDC level shifter block.

**Remark:** When used in an HDMI dongle, the DDET function **must** be enabled for correct operation in accordance with DisplayPort interoperability guidelines. When used in a DVI dongle, the DDET function **must** be disabled.

The PTN3381B also provides voltage translation for the Hot Plug Detect (HPD) signal from 0 V to 5 V on the sink side to 0 V to 3.3 V on the source side.

PTN3381B includes an onboard 5 V DC regulator, designed to provide the required 5 V power supply to the DVI or HDMI connector, thereby eliminating the need for a separate external regulator. The onboard regulator needs only two external capacitors to operate, and its output is active whenever a valid 3.3 V is applied to the PTN3381B V<sub>DD</sub> pins. The back drive protection on 5 V output prevents back-drive current from 5 V output to the input supply. The short-circuit protection limits current flowing through the supply, and the overcurrent protection prevents overload conditions at the charge pump output.

The PTN3381B does not re-time any data. It contains no state machines except for the DDC/I<sup>2</sup>C-bus block. No inputs or outputs of the device are latched or clocked. Because the PTN3381B acts as a transparent level shifter, no reset is required.

## 7.1 Enable and disable features

PTN3381B offers different ways to enable or disable functionality, using the Output Enable (OE\_N), and DDC Enable (DDC\_EN) inputs. Whenever the PTN3381B is disabled, the device will be in standby mode and power consumption will be minimal; otherwise the PTN3381B will be in active mode and power consumption will be nominal. These two inputs each affect the operation of PTN3381B differently: OE\_N controls the TMDS channels, DDC\_EN affects only the DDC channel, and HPD\_SINK does not affect either of the channels. The following sections and truth table describe their detailed operation.

### 7.1.1 Hot plug detect

The HPD channel of PTN3381B functions as a level-shifting buffer to pass the HPD logic signal from the display sink device (via input HPD\_SINK) on to the display source device (via output HPD\_SOURCE).

The output logic state of HPD\_SOURCE output always follows the logic state of input HPD\_SINK, regardless of whether the device is in active or standby mode.

### 7.1.2 Output Enable function (OE\_N)

When input OE\_N is asserted (active LOW), the IN\_Dx and OUT\_Dx signals are fully functional. Input termination resistors are enabled and the internal bias circuits are turned on.

When OE\_N is de-asserted (inactive HIGH), the OUT\_Dx outputs are in a high-impedance state and drive zero output current. The IN\_Dx input buffers are disabled and IN\_Dx termination is disabled. Power consumption is minimized.

**Remark:** Note that OE\_N signal level has no influence on the HPD\_SINK input, HPD\_SOURCE output, or the SCL and SDA level shifters. A transition from HIGH to LOW at OE\_N may disable the DDC channel for up to 20  $\mu$ s.

### 7.1.3 DDC channel enable function (DDC\_EN)

The DDC\_EN pin is active HIGH and can be used to isolate a badly behaved slave. When DDC\_EN is LOW, the DDC channel is turned off. The DDC\_EN input should never change state during an I<sup>2</sup>C-bus operation. Note that disabling DDC\_EN during a bus operation may hang the bus, while enabling DDC\_EN during bus traffic would corrupt the I<sup>2</sup>C-bus operation. Hence, DDC\_EN should only be toggled while the bus is idle. (See I<sup>2</sup>C-bus specification).

### 7.1.4 Enable/disable truth table

Table 3. HPD\_SINK, OE\_N and DDC\_EN enabling truth table

Inputs			Channels				Mode
HPD_SINK	OE_N <a href="#">[1]</a>	DDC_EN <a href="#">[2]</a>	IN_Dx	OUT_Dx <sup>[3]</sup>	DDC <sup>[4]</sup>	HPD_SOURCE <sup>[5]</sup>	
LOW	LOW	LOW	50 Ω termination to V <sub>RX(bias)</sub>	enabled	high-impedance	LOW	Active; DDC disabled
LOW	LOW	HIGH	50 Ω termination to V <sub>RX(bias)</sub>	enabled	SDA_SINK connected to SDA_SOURCE and SCL_SINK connected to SCL_SOURCE	LOW	Active; DDC enabled
LOW	HIGH	LOW	high-impedance	high-impedance; zero output current	high-impedance	LOW	Standby
LOW	HIGH	HIGH	high-impedance	high-impedance; zero output current	SDA_SINK connected to SDA_SOURCE and SCL_SINK connected to SCL_SOURCE	LOW	Standby; DDC enabled
HIGH	LOW	LOW	50 Ω termination to V <sub>RX(bias)</sub>	enabled	high-impedance	HIGH	Active; DDC disabled
HIGH	LOW	HIGH	50 Ω termination to V <sub>RX(bias)</sub>	enabled	SDA_SINK connected to SDA_SOURCE and SCL_SINK connected to SCL_SOURCE	HIGH	Active; DDC enabled
HIGH	HIGH	LOW	high-impedance	high-impedance; zero output current	high-impedance	HIGH	Standby
HIGH	HIGH	HIGH	high-impedance	high-impedance; zero output current	SDA_SINK connected to SDA_SOURCE and SCL_SINK connected to SCL_SOURCE	HIGH	Standby; DDC enabled

[1] A HIGH level on input OE\_N disables only the TMDS channels.

[2] A LOW level on input DDC\_EN disables only the DDC channel.

[3] OUT\_Dx channels 'enabled' means outputs OUT\_Dx toggling in accordance with IN\_Dx differential input voltage switching.

[4] DDC channel 'enabled' means SDA\_SINK is connected to SDA\_SOURCE and SCL\_SINK is connected to SCL\_SOURCE.

[5] The HPD\_SOURCE output logic state always follows the HPD\_SINK input logic state.

### 7.2 Analog current reference

The REXT pin (pin 6) is an analog current sense port used to provide an accurate current reference for the differential outputs OUT\_Dx. For best output voltage swing accuracy, use of a 10 kΩ resistor (1 % tolerance) connected between this terminal and GND is recommended.

If an external 10 kΩ ± 1 % resistor is not used, this pin can be left open-circuit, or connected to GND or V<sub>DD</sub>, either directly (0 Ω) or using pull-up or pull-down resistors of value less than 10 kΩ. In any of these cases, the output will function normally but at reduced accuracy over voltage and temperature of the following parameters: output levels (V<sub>OL</sub>), differential output voltage swing, and rise and fall time accuracy.

### 7.3 Programmable pre-emphasis

PTN3381B includes an optional programmable pre-emphasis feature, allowing adaptor or motherboard PCB designers to extend speed performance or support longer cable drive. The pre-emphasis feature, when enabled, adds a selectable amount of pre-emphasis to each bit transition by injecting a momentary current pulse (typically 200 ps to 400 ps long) to help overcome cable or trace losses.

Pre-emphasis is not needed for normal HDMI operation at speeds below 1.65 Gbit/s and is not required to meet eye diagram compliance. At the user's discretion, it can be enabled in order to provide additional signal boost in difficult or lossy signaling environments such as long cables or lossy media.

It should be noted that by enabling pre-emphasis, in addition to the AC effect of the pre-emphasis pulse on the signal transition, also a constant DC current is added in order to provide the necessary headroom, which will affect V<sub>OH</sub> and V<sub>OL</sub> static levels. This should be taken into account when designing for HDMI or DVI single-ended (DC) voltage compliance. For full HDMI or DVI compliance in normal applications, the default mode (pre-emphasis off) is recommended.

The pre-emphasis feature is programmed by means of two CMOS input pins, PES1 and PES0, according to [Table 4](#):

**Table 4. PTN3381B pre-emphasis logic table**

PES1 (pin 10)	PES0 (pin 3)	Level
0	0	0 dB (default)
0	1	3.5 dB (150 %)
1	0	6 dB (200 %)
1	1	Test mode <sup>[1]</sup>

[1] Should not be used in normal application.

### 7.4 Backdrive current protection

The PTN3381B is designed for backdrive prevention on all sink-side TMDS outputs, sink-side DDC I/Os and the HPD\_SINK input. This supports user scenarios where the display is connected and powered, but the PTN3381B is unpowered. In these cases, the PTN3381B will sink no more than a negligible amount of leakage current, and will block the display (sink) termination network from driving the power supply of the PTN3381B or that of the inactive DVI or HDMI source.

### 7.5 Active DDC buffer with rise time accelerator

The PTN3381B DDC channel, besides providing 3.3 V to 5 V level shifting, includes active buffering and rise time acceleration which allows up to 18 meters bus extension for reliable DDC applications. While retaining all the operating modes and features of the I<sup>2</sup>C-bus system during the level shifts, it permits extension of the I<sup>2</sup>C-bus by providing bidirectional buffering for both the data (SDA) and the clock (SCL) line as well as the rise time accelerator on the sink-side port (SCL\_SINK and SDA\_SINK) enabling the bus to drive a load up to 1400 pF or distance of 18 m on the sink-side port, and 400 pF on the source-side port (SCL\_SOURCE and SCA\_SOURCE). Using the PTN3381B for DVI or HDMI level shifting enables the system designer to isolate bus capacitance to meet HDMI DDC version 1.3 distance specification. The SDA and SCL pins are overvoltage tolerant and are high-impedance when the PTN3381B is unpowered or when DDC\_EN is LOW.

PTN3381B has rise time accelerators on the sink-side port (SCL\_SINK and SDA\_SINK) only. During positive bus transitions on the sink-side port, a current source is switched on to quickly slew the SCL\_SINK and SDA\_SINK lines HIGH once the 5 V DDC bus V<sub>IL</sub> threshold level of around 1.5 V is exceeded, and turns off as the 5 V DDC bus V<sub>IH</sub> threshold voltage of approximately 3.5 V is approached.

### 7.6 I<sup>2</sup>C-bus based HDMI dongle detection

The PTN3381B includes an on-board I<sup>2</sup>C-bus slave ROM which provides a means to detect the presence of an HDMI dongle by the system through the DDC channel, accessible via ports SDA\_SOURCE and SCL\_SOURCE. This allows system vendors to detect HDMI dongle presence through the already available DDC/I<sup>2</sup>C-bus port using a predetermined bus sequence. Please see [Section 8](#) for more information.

For the I<sup>2</sup>C-bus HDMI Dongle Detect function to be active, input pin DDET (dongle detect) should be tied HIGH. When DDET is LOW, the PTN3381B will not respond to an I<sup>2</sup>C-bus command. When used in an HDMI dongle, the DDET function **must** be enabled for correct operation in accordance with DisplayPort interoperability guidelines. When used in a DVI dongle, the DDET function **must** be disabled.

The HDMI dongle detection is accomplished by accessing the PTN3381B on-board I<sup>2</sup>C-bus slave ROM using a simple sequential I<sup>2</sup>C-bus Read operation as described below.

#### 7.6.1 Slave address



7.6.2 Read operation

The slave device address of PTN3381B is 80h. PTN3381B will respond to a Read command to slave address 81h (PTN3381B will respond with an ACK to a Write command to address 80h). Following the Read command, the PTN3381B will respond with the contents of its internal ROM, as a sequence of 16 bytes, for as long as the master continues to issue clock edges with an acknowledge after each byte. The 16-byte sequence represents the 'DP-HDMI ADAPTOR<EOT>' symbol converted to ASCII and is documented in [Table 5](#).

The PTN3381B auto-increments its internal ROM address pointer (0h through Fh) as long as it continues to receive clock edges from the master with an acknowledge after each byte. If the master continues to issue clock edges past the 16<sup>th</sup> byte, the PTN3381B will respond with a data byte of FFh. If the master does not acknowledge a received byte, the PTN3381B internal address pointer will be reset to 0 and a new Read sequence should be started by the master. Access to the 16-byte is by sequential read only as described above; there is no random-access possible to any specific byte in the ROM.

Table 5. DisplayPort - HDMI Adaptor Detection ROM content

Internal pointer offset (hex)	0	1	2	3	4	5	6	7	8	9	A	B	C	D	E	F
Data (hex)	44	50	2D	48	44	4D	49	20	41	44	41	50	54	4F	52	04

Table 6. HDMI dongle detect transaction sequence outline

Phase	I <sup>2</sup> C transaction	Transmitting	Bit								Status		
			7	6	5	4	3	2	1	R/W	Master	Slave	
1	START	master									optional	-	
2	Write command	master	1	0	0	0	0	0	0	0	0	optional	-
3	Acknowledge	slave									-	mandatory	
4	Word address offset	master	word address offset data byte								optional	-	
5	Acknowledge	slave									-	mandatory	
6	STOP	master									optional	-	
7	START	master									mandatory	-	
8	Read command	master	1	0	0	0	0	0	0	0	1	mandatory	-
9	Acknowledge	slave									-	mandatory	
10	Read data	slave	data byte at offset 0								-	mandatory	
11	Acknowledge	master									mandatory	-	
12	Read data	slave	data byte at offset 1								-	mandatory	
13	:	:									-	-	
:	:	:									-	-	
40	Read data	slave	data byte at offset 15								-	mandatory	
41	Not Acknowledge	master									mandatory	-	
42	STOP	master									mandatory	-	

**Remark:** If the slave does not acknowledge the above transaction sequence, the entire sequence should be retried by the source.

**7.7 Characteristics of the I<sup>2</sup>C-bus**

The I<sup>2</sup>C-bus is for 2-way, 2-line communication between different ICs or modules. The two lines are a Serial Data line (SDA) and a Serial Clock Line (SCL). Both lines must be connected to a positive supply via a pull-up resistor when connected to the output stages of a device. Data transfer may be initiated only when the bus is not busy.

**7.7.1 Bit transfer**

One data bit is transferred during each clock phase. The data on the SDA line must remain stable during the HIGH period of the clock pulse as changes in the data line at this time will be interpreted as control signals (see [Figure 5](#)).

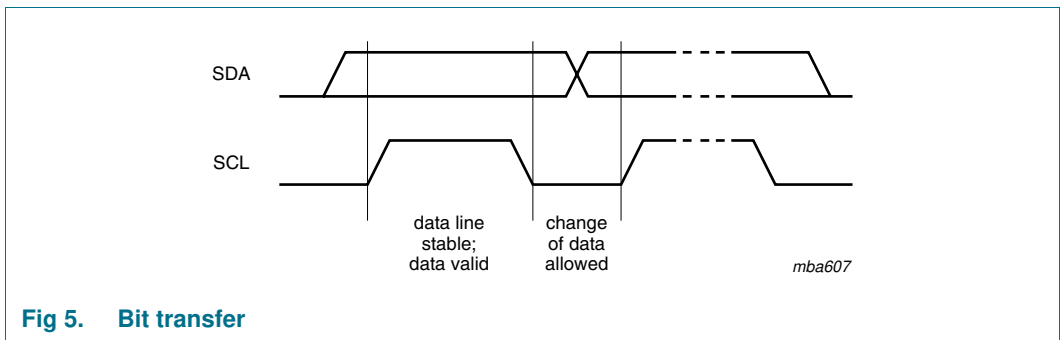

**Fig 5. Bit transfer**

**7.7.2 START and STOP conditions**

Both data and clock lines remain HIGH when the bus is not busy. A HIGH-to-LOW transition of the data line, while the clock is HIGH is defined as the START condition (S). A LOW-to-HIGH transition of the data line while the clock is HIGH is defined as the STOP condition (P). See [Figure 6](#).

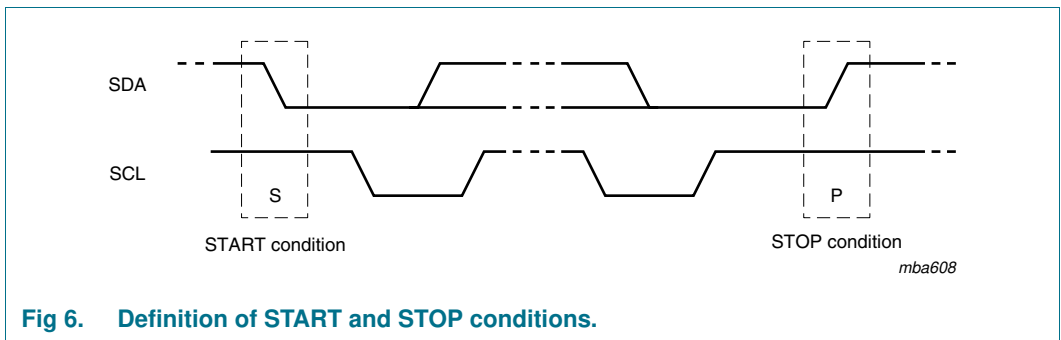

**Fig 6. Definition of START and STOP conditions.**

**7.7.3 System configuration**

An I<sup>2</sup>C-bus device generating a message is a 'transmitter', a device receiving is the 'receiver'. The device that controls the message is the 'master' and the devices which are controlled by the master are the 'slaves'. See [Figure 7](#).



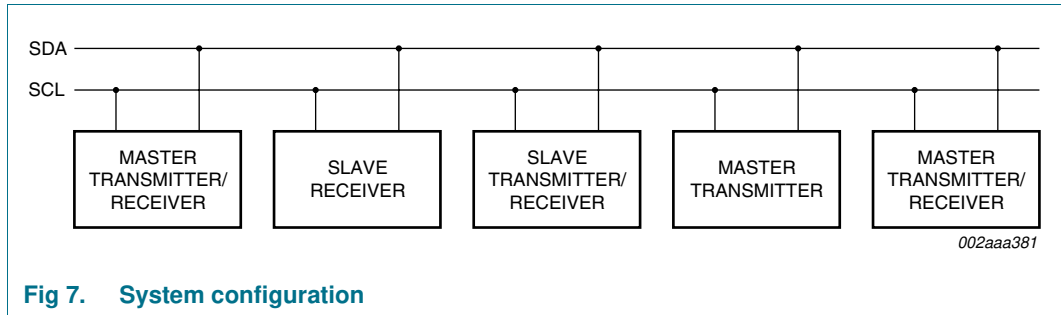

Fig 7. System configuration

7.7.4 Acknowledge

The number of data bytes transferred between the START and the STOP conditions from transmitter to receiver is not limited. Each byte of eight bits is followed by one acknowledge bit. The acknowledge bit is a HIGH level put on the bus by the transmitter, whereas the master generates an extra acknowledge related clock pulse.

A slave receiver which is addressed must generate an acknowledge after the reception of each byte. Also, a master must generate an acknowledge after the reception of each byte that has been clocked out of the slave transmitter. The device that acknowledges has to pull down the SDA line during the acknowledge clock pulse so that the SDA line is stable LOW during the HIGH period of the acknowledge related clock pulse, set-up and hold times must be taken into account.

A master receiver must signal an end of data to the transmitter by not generating an acknowledge on the last byte that has been clocked out of the slave. In this event, the transmitter must leave the data line HIGH to enable the master to generate a STOP condition.

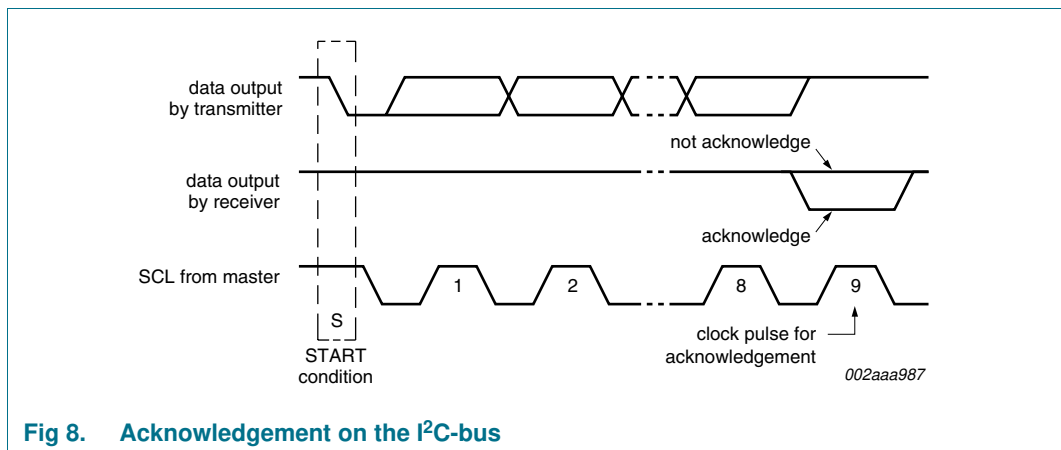

Fig 8. Acknowledgement on the I2C-bus

## 8. Application design-in information

### 8.1 Dongle or cable adaptor detect discovery mechanism

The PTN3381B supports the source-side dongle detect discovery mechanism described in *VESA DisplayPort Interoperability Guideline Version 1.1*.

When a source-side cable adaptor is plugged into a multi-mode source device that supports multiple standards such as DisplayPort, DVI and HDMI, a discovery mechanism is needed for the multi-mode source to configure itself for outputting DisplayPort, DVI or HDMI compliant signals through the dongle or cable adaptor. The discovery mechanism ensures that a multi-mode source device only sends either DVI or HDMI signals when a valid DVI or HDMI cable adaptor is present.

The *VESA Interoperability Guideline* recommends that a multi-mode source to power up with both DDC and AUX CH disabled. After initialization, the source device can use a variety of mechanisms to decide whether a dongle or cable adaptor is present by detecting pin 13 on the DisplayPort connector. Depending on the voltage level detected at pin 13, the source configures itself either:

- as a DVI or HDMI source (see below paragraph for detection between DVI and HDMI), and enables DDC, while keeping AUX CH disabled, **or**
- as a DisplayPort source and enables AUX CH, while keeping DDC disabled.

The monitoring of the voltage level on pin 13 by a multi-mode source device is optional. A multi-mode source may also e.g. attempt an AUX CH read transaction and, if the transaction fails, a DDC transaction to discover the presence/absence of a cable adaptor.

Furthermore, a source that supports both DVI and HDMI can discover whether a DVI or HDMI dongle or cable adaptor is present by using a variety of discovery procedures. One possible method is to check the voltage level of pin 14 of the DisplayPort connector. Pin 14 also carries CEC signal used for HDMI. Please note that other HDMI devices on the CEC line may be momentarily pulling down pin 14 as a part of CEC protocol.

The *VESA Interoperability Guideline* recommends that a multi-mode source should distinguish a source-side HDMI cable adaptor from a DVI cable adaptor by checking the DDC buffer ID as described in [Section 7.6 “I<sup>2</sup>C-bus based HDMI dongle detection”](#). While it is optional for a multi-mode source to use the I<sup>2</sup>C-bus based HDMI dongle detection mechanism, it is mandatory for HDMI dongle or cable adaptor to respond to the I<sup>2</sup>C-bus read command described in [Section 7.7](#). The PTN3381B provides an integrated I<sup>2</sup>C-bus slave ROM to support this mandatory HDMI dongle detect mechanism for HDMI dongles.

For a DisplayPort-to-HDMI source-side dongle or cable adaptor, DDET must be tied HIGH to enable the I<sup>2</sup>C-based HDMI dongle detection response function of PTN3381B. For a DisplayPort-to-DVI sink-side dongle or cable adaptor, DDET must be tied LOW to disable the function.

## 9. Limiting values

**Table 7. Limiting values**

In accordance with the Absolute Maximum Rating System (IEC 60134).

Symbol	Parameter	Conditions	Min	Max	Unit
V <sub>DD</sub>	supply voltage	(3.3 V)	-0.3	+4.6	V
V <sub>I</sub>	input voltage	3.3 V CMOS inputs	-0.3	V <sub>DD</sub> + 0.5	V
		5.0 V CMOS inputs	-0.3	6.0	V
R <sub>L</sub>	load resistance	5 V regulator output	25	-	Ω
T <sub>stg</sub>	storage temperature		-65	+150	°C
V <sub>ESD</sub>	electrostatic discharge voltage	HBM	[1] -	4000	V
		CDM	[2] -	1000	V

[1] Human Body Model: ANSI/EOS/ESD-S5.1-1994, standard for ESD sensitivity testing, Human Body Model - Component level; Electrostatic Discharge Association, Rome, NY, USA.

[2] Charged Device Model: ANSI/EOS/ESD-S5.3-1-1999, standard for ESD sensitivity testing, Charged Device Model - Component level; Electrostatic Discharge Association, Rome, NY, USA.

## 10. Recommended operating conditions

**Table 8. Recommended operating conditions**

Symbol	Parameter	Conditions	Min	Typ	Max	Unit
V <sub>DD</sub>	supply voltage		3.0	3.3	3.6	V
V <sub>I</sub>	input voltage	3.3 V CMOS inputs	0	-	3.6	V
		5.0 V CMOS inputs	0	-	5.5	V
V <sub>I(AV)</sub>	average input voltage	IN_Dn+, IN_Dn- inputs	[1] -	0	-	V
R <sub>ref(ext)</sub>	external reference resistance	connected between pin REXT (pin 6) and GND	[2] -	10 ± 1 %	-	kΩ
I <sub>load</sub>	load current	5 V regulator output	-	-	75	mA
C <sub>o(reg)</sub>	regulator output capacitance	external capacitor on pin V5OUT	[3] -	1	-	μF
C <sub>reg(ext)</sub>	external regulator capacitance	from pin CP to pin CN	[3] -	330	-	nF
T <sub>amb</sub>	ambient temperature	operating in free air	-40	-	+85	°C

[1] Input signals to these pins must be AC-coupled.

[2] Operation without external reference resistor is possible but will result in reduced output voltage swing accuracy. For details, see [Section 7.2](#).

[3] A ceramic capacitor with ESR < 100 mΩ is recommended and should be placed close to the pin(s).

## 10.1 Current consumption

Table 9. Current consumption

Symbol	Parameter	Conditions	Min	Typ	Max	Unit
I <sub>DD</sub>	supply current	OE_N = 0; Active mode				
		no load	10	30	50	mA
		with 75 mA load	-	200	300	mA
		OE_N = 1 and DDC_EN = 0; Standby mode; no load	-	-	5	mA

## 11. Characteristics

### 11.1 Differential inputs

Table 10. Differential input characteristics for IN\_Dx signals

Symbol	Parameter	Conditions	Min	Typ	Max	Unit
UI	unit interval <sup>[1]</sup>		<sup>[2]</sup> 600	-	4000	ps
V <sub>RX_DIFFp-p</sub>	differential input peak-to-peak voltage		<sup>[3]</sup> 0.175	-	1.200	V
T <sub>RX_EYE</sub>	receiver eye time	minimum eye width at IN_Dx input pair	0.8	-	-	UI
V <sub>i(cm)M(AC)</sub>	peak common-mode input voltage (AC)	includes all frequencies above 30 kHz	<sup>[4]</sup> -	-	100	mV
Z <sub>RX_DC</sub>	DC input impedance		40	50	60	Ω
V <sub>RX(bias)</sub>	bias receiver voltage		<sup>[5]</sup> 1.0	1.2	1.4	V
Z <sub>I(se)</sub>	single-ended input impedance	inputs in high-impedance state	<sup>[6]</sup> 100	-	-	kΩ

[1] UI (unit interval) = t<sub>bit</sub> (bit time).

[2] UI is determined by the display mode. Nominal bit rate ranges from 250 Mbit/s to 1.65 Gbit/s per lane. Nominal UI at 1.65 Gbit/s = 606 ps.

[3] V<sub>RX\_DIFFp-p</sub> = 2 × |V<sub>RX\_D+</sub> - V<sub>RX\_D-</sub>|. Applies to IN\_Dx signals.

[4] V<sub>i(cm)M(AC)</sub> = |V<sub>RX\_D+</sub> + V<sub>RX\_D-</sub>| / 2 - V<sub>RX(cm)</sub>.  
V<sub>RX(cm)</sub> = DC (avg) of |V<sub>RX\_D+</sub> + V<sub>RX\_D-</sub>| / 2.

[5] Intended to limit power-up stress on chip set's PCIe output buffers.

[6] Differential inputs will switch to a high-impedance state when OE\_N is HIGH.

## 11.2 Differential outputs

The level shifter's differential outputs are designed to meet HDMI version 1.3 and DVI version 1.0 specifications.

**Table 11. Differential output characteristics for OUT\_Dx signals**

Symbol	Parameter	Conditions	Min	Typ	Max	Unit
$V_{OH(se)}$	single-ended HIGH-level output voltage	PES[1:0] = 00b	[1] $V_{TT} - 0.01$	$V_{TT}$	$V_{TT} + 0.01$	V
$V_{OL(se)}$	single-ended LOW-level output voltage	PES[1:0] = 00b	[2] $V_{TT} - 0.60$	$V_{TT} - 0.50$	$V_{TT} - 0.40$	V
$\Delta V_{O(se)}$	single-ended output voltage variation	logic 1 and logic 0 state applied respectively to differential inputs IN_Dn; $R_{ref(ext)}$ connected; see <a href="#">Table 8</a>	[3] 400	500	600	mV
$I_{OZ}$	OFF-state output current	single-ended	-	-	10	$\mu$ A
$t_r$	rise time	20 % to 80 %	75	-	180	ps
$t_f$	fall time	80 % to 20 %	75	-	180	ps
$t_{sk}$	skew time	intra-pair	[4] -	-	10	ps
		inter-pair	[5] -	-	250	ps
$t_{jit}$	jitter time	jitter contribution	[6] -	-	10	ps

[1]  $V_{TT}$  is the DC termination voltage in the HDMI or DVI sink.  $V_{TT}$  is nominally 3.3 V.

[2] The open-drain output pulls down from  $V_{TT}$ .

[3] Swing down from TMDS termination voltage ( $3.3\text{ V} \pm 10\%$ ).

[4] This differential skew budget is in addition to the skew presented between IN\_Dn+ and IN\_Dn- paired input pins.

[5] This lane-to-lane skew budget is in addition to skew between differential input pairs.

[6] Jitter budget for differential signals as they pass through the level shifter.

## 11.3 HPD\_SINK input, HPD\_SOURCE output

**Table 12. HPD characteristics**

Symbol	Parameter	Conditions	Min	Typ	Max	Unit
$V_{IH}$	HIGH-level input voltage	HPD_SINK	[1] 2.0	5.0	5.3	V
$V_{IL}$	LOW-level input voltage	HPD_SINK	0	-	0.8	V
$I_{LI}$	input leakage current	HPD_SINK	-	-	15	$\mu$ A
$V_{OH}$	HIGH-level output voltage	HPD_SOURCE	2.5	-	$V_{DD}$	V
$V_{OL}$	LOW-level output voltage	HPD_SOURCE	0	-	0.2	V
$t_{PD}$	propagation delay	from HPD_SINK to HPD_SOURCE; 50 % to 50 %	[2] -	-	200	ns
$t_t$	transition time	HPD_SOURCE rise/fall; 10 % to 90 %	[3] 1	-	20	ns
$R_{pd}$	pull-down resistance	HPD_SINK input pull-down resistor	[4] 100	200	300	k $\Omega$

[1] Low-speed input changes state on cable plug/unplug.

[2] Time from HPD\_SINK changing state to HPD\_SOURCE changing state. Includes HPD\_SOURCE rise/fall time.

[3] Time required to transition from  $V_{OH}$  to  $V_{OL}$  or from  $V_{OL}$  to  $V_{OH}$ .

[4] Guarantees HPD\_SINK is LOW when no display is plugged in.

## 11.4 OE\_N, DDC\_EN and DDET inputs

Table 13. OE\_N, DDC\_EN and DDET input characteristics

Symbol	Parameter	Conditions	Min	Typ	Max	Unit
V <sub>IH</sub>	HIGH-level input voltage		2.0	-		V
V <sub>IL</sub>	LOW-level input voltage			-	0.8	V
I <sub>LI</sub>	input leakage current	OE_N pin	[1] -	-	10	μA

[1] Measured with input at V<sub>IH</sub> maximum and V<sub>IL</sub> minimum.

## 11.5 DDC characteristics

Table 14. DDC characteristics

Symbol	Parameter	Conditions	Min	Typ	Max	Unit
<b>Input and output SCL_SOURCE and SDA_SOURCE; V<sub>CC1</sub> = 3.0 V to 3.6 V [1]</b>						
V <sub>IH</sub>	HIGH-level input voltage		0.7V <sub>CC1</sub>	-	3.6	V
V <sub>IL</sub>	LOW-level input voltage		-0.5	-	+0.3V <sub>CC1</sub>	V
V <sub>ILc</sub>	contention LOW-level input voltage		-0.5	0.4	-	V
I <sub>LI</sub>	input leakage current	V <sub>I</sub> = 3.6 V	-	-	10	μA
I <sub>IL</sub>	LOW-level input current	V <sub>I</sub> = 0.2 V	-	-	10	μA
V <sub>OL</sub>	LOW-level output voltage	I <sub>OL</sub> = 100 μA or 6 mA	0.47	0.52	0.6	V
V <sub>OL</sub> -V <sub>ILc</sub>	difference between LOW-level output and LOW-level input voltage contention	guaranteed by design	-	-	70	mV
C <sub>io</sub>	input/output capacitance	V <sub>I</sub> = 3 V or 0 V; V <sub>DD</sub> = 3.3 V	-	6	7	pF
		V <sub>I</sub> = 3 V or 0 V; V <sub>DD</sub> = 0 V	-	6	7	pF
<b>Input and output SDA_SINK and SCL_SINK; V<sub>CC2</sub> = 4.5 V to 5.5 V [2]</b>						
V <sub>IH</sub>	HIGH-level input voltage		0.7V <sub>CC2</sub>	-	5.5	V
V <sub>IL</sub>	LOW-level input voltage		-0.5	-	+1.5	V
I <sub>LI</sub>	input leakage current	V <sub>I</sub> = 5.5 V	-	-	10	μA
I <sub>IL</sub>	LOW-level input current	V <sub>I</sub> = 0.2 V	-	-	10	μA
V <sub>OL</sub>	LOW-level output voltage	I <sub>OL</sub> = 6 mA	-	0.1	0.2	V
C <sub>io</sub>	input/output capacitance	V <sub>I</sub> = 3 V or 0 V; V <sub>DD</sub> = 3.3 V	-	-	7	pF
		V <sub>I</sub> = 3 V or 0 V; V <sub>DD</sub> = 0 V	-	6	7	pF
I <sub>trt(pu)</sub>	transient boosted pull-up current	V <sub>CC2</sub> = 4.5 V; slew rate = 1.25 V/μs	-	6	-	mA

[1] V<sub>CC1</sub> is the pull-up voltage for DDC source.

[2] V<sub>CC2</sub> is the pull-up voltage for DDC sink.

## 11.6 5 V DC regulator characteristics

**Table 15.** 5 V DC regulator characteristics

Symbol	Parameter	Conditions	Min	Typ	Max	Unit
$V_{DD}$	supply voltage		3.0	3.3	3.6	V
$V_O$	output voltage	5 V regulator output	4.7	5	5.3	V
$I_{load}$	load current	5 V regulator output	-	-	75	mA
$I_{O(sc)}$	short-circuit output current		100	150	200	mA
$I_{bckdrv}$	backdrive current	5 V regulator output	-	-	10	$\mu$ A
$V_{O(ripple)(p-p)}$	peak-to-peak ripple output voltage	$C_{O(reg)} = 1 \mu\text{F}$	<a href="#">[1]</a> -	250	400	mV
$\eta$	efficiency	$I_{load} > 10 \text{ mA}$	70	75	80	%

[1] Recommend low ESR ceramic output capacitor of 2  $\mu\text{F}$  to reduce the output ripple.

## 12. Package outline

HVQFN48: plastic thermal enhanced very thin quad flat package; no leads; 48 terminals; body 7 x 7 x 0.85 mm

SOT619-1

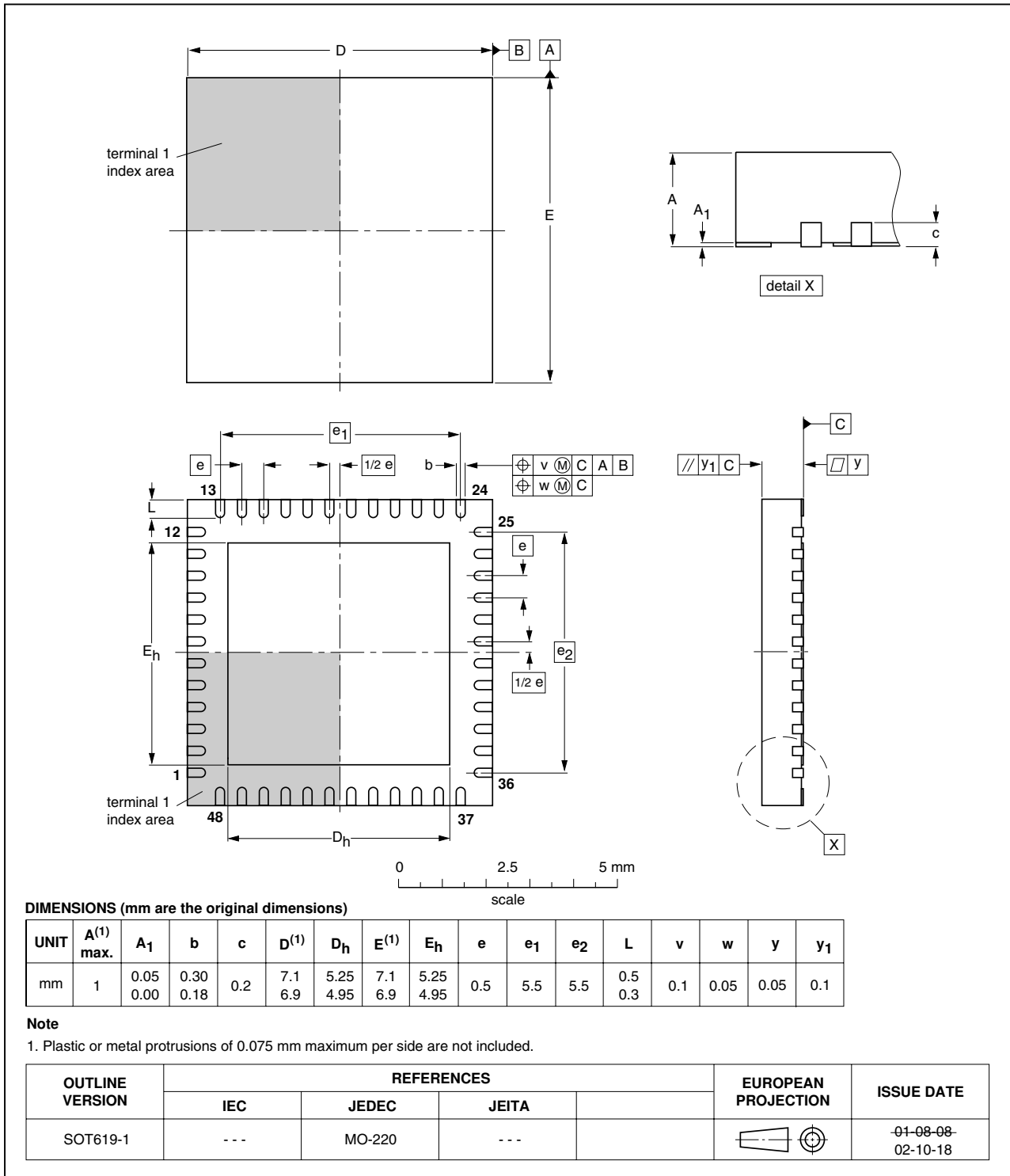

Fig 9. Package outline SOT619-1 (HVQFN48)



## 13. Soldering of SMD packages

This text provides a very brief insight into a complex technology. A more in-depth account of soldering ICs can be found in Application Note *AN10365 "Surface mount reflow soldering description"*.

### 13.1 Introduction to soldering

Soldering is one of the most common methods through which packages are attached to Printed Circuit Boards (PCBs), to form electrical circuits. The soldered joint provides both the mechanical and the electrical connection. There is no single soldering method that is ideal for all IC packages. Wave soldering is often preferred when through-hole and Surface Mount Devices (SMDs) are mixed on one printed wiring board; however, it is not suitable for fine pitch SMDs. Reflow soldering is ideal for the small pitches and high densities that come with increased miniaturization.

### 13.2 Wave and reflow soldering

Wave soldering is a joining technology in which the joints are made by solder coming from a standing wave of liquid solder. The wave soldering process is suitable for the following:

- Through-hole components
- Leaded or leadless SMDs, which are glued to the surface of the printed circuit board

Not all SMDs can be wave soldered. Packages with solder balls, and some leadless packages which have solder lands underneath the body, cannot be wave soldered. Also, leaded SMDs with leads having a pitch smaller than ~0.6 mm cannot be wave soldered, due to an increased probability of bridging.

The reflow soldering process involves applying solder paste to a board, followed by component placement and exposure to a temperature profile. Leaded packages, packages with solder balls, and leadless packages are all reflow solderable.

Key characteristics in both wave and reflow soldering are:

- Board specifications, including the board finish, solder masks and vias
- Package footprints, including solder thieves and orientation
- The moisture sensitivity level of the packages
- Package placement
- Inspection and repair
- Lead-free soldering versus SnPb soldering

### 13.3 Wave soldering

Key characteristics in wave soldering are:

- Process issues, such as application of adhesive and flux, clinching of leads, board transport, the solder wave parameters, and the time during which components are exposed to the wave
- Solder bath specifications, including temperature and impurities

## 13.4 Reflow soldering

Key characteristics in reflow soldering are:

- Lead-free versus SnPb soldering; note that a lead-free reflow process usually leads to higher minimum peak temperatures (see [Figure 10](#)) than a SnPb process, thus reducing the process window
- Solder paste printing issues including smearing, release, and adjusting the process window for a mix of large and small components on one board
- Reflow temperature profile; this profile includes preheat, reflow (in which the board is heated to the peak temperature) and cooling down. It is imperative that the peak temperature is high enough for the solder to make reliable solder joints (a solder paste characteristic). In addition, the peak temperature must be low enough that the packages and/or boards are not damaged. The peak temperature of the package depends on package thickness and volume and is classified in accordance with [Table 16](#) and [17](#)

**Table 16. SnPb eutectic process (from J-STD-020C)**

Package thickness (mm)	Package reflow temperature (°C)	
	Volume (mm <sup>3</sup> )	
	< 350	≥ 350
< 2.5	235	220
≥ 2.5	220	220

**Table 17. Lead-free process (from J-STD-020C)**

Package thickness (mm)	Package reflow temperature (°C)		
	Volume (mm <sup>3</sup> )		
	< 350	350 to 2000	> 2000
< 1.6	260	260	260
1.6 to 2.5	260	250	245
> 2.5	250	245	245

Moisture sensitivity precautions, as indicated on the packing, must be respected at all times.

Studies have shown that small packages reach higher temperatures during reflow soldering, see [Figure 10](#).