



Chipsmall Limited consists of a professional team with an average of over 10 year of expertise in the distribution of electronic components. Based in Hongkong, we have already established firm and mutual-benefit business relationships with customers from,Europe,America and south Asia,supplying obsolete and hard-to-find components to meet their specific needs.

With the principle of “Quality Parts,Customers Priority,Honest Operation,and Considerate Service”,our business mainly focus on the distribution of electronic components. Line cards we deal with include Microchip,ALPS,ROHM,Xilinx,Pulse,ON,Everlight and Freescale. Main products comprise IC,Modules,Potentiometer,IC Socket,Relay,Connector.Our parts cover such applications as commercial,industrial, and automotives areas.

We are looking forward to setting up business relationship with you and hope to provide you with the best service and solution. Let us make a better world for our industry!



Contact us

Tel: +86-755-8981 8866 Fax: +86-755-8427 6832

Email & Skype: info@chipsmall.com Web: www.chipsmall.com

Address: A1208, Overseas Decoration Building, #122 Zhenhua RD., Futian, Shenzhen, China



THIS COPY IS PROVIDED ON A RESTRICTED BASIS AND IS NOT TO BE USED IN ANY WAY DETRIMENTAL TO THE INTERESTS OF PANDUIT CORP.

PANDUIT PART NUMBER	STUD SIZE	DIMENSIONS in.				
		A ±.03	W ±.01	C ±.02	M ±.03	H ±.01
PV14-6FFB-3K	#6	.80 (20.32)	.28 (7.11)	.19 (4.83)	.64 (16.26)	.15 (3.81)
PV14-8FFB-3K	#8	.86 (21.84)	.31 (7.87)	.23 (5.84)	.68 (17.27)	.17 (4.32)
PV14-10FFB-3K	#10	.86 (21.84)	.35 (8.89)	.23 (5.84)	.68 (17.27)	.20 (5.08)

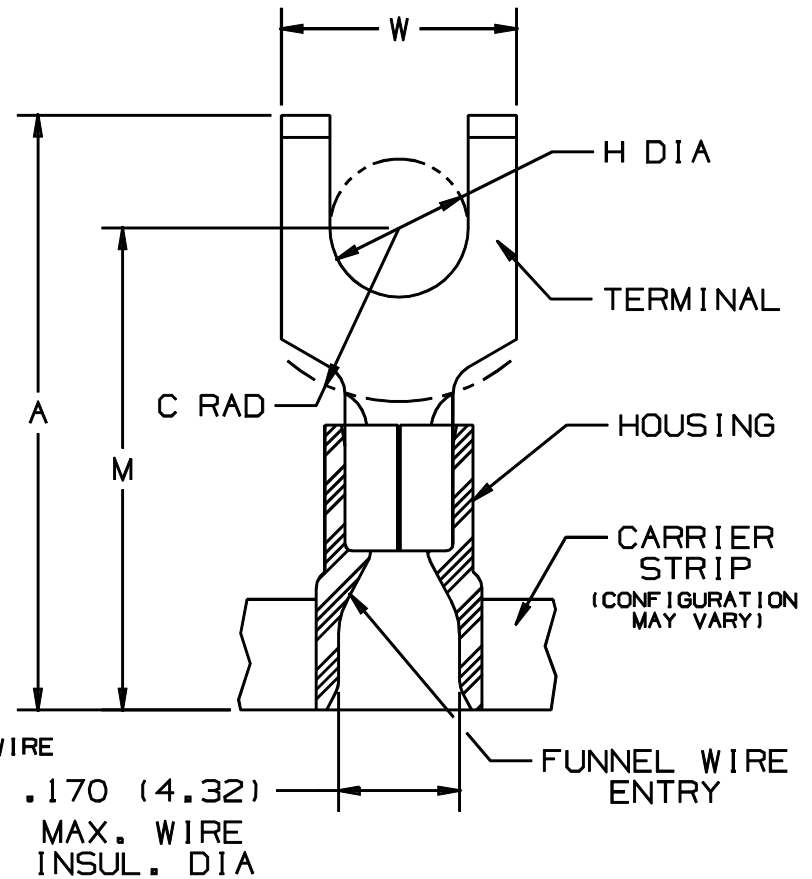

NOTES :

- UL LISTED AND CSA CERTIFIED FOR :
 A. 600 V MAX. VOLTAGE RATING
 B. 221°F (105°C) MAX. TEMP. RATING
 C. #16-14 AWG (1.5-2.5 mm²) SOLID OR STRANDED, COPPER WIRE
- PACKAGE QTY. : 3K = 3000 PCS.
CONTINUOUS MOLDED CARRIER STRIP
- MATERIAL :
 A. STAMPING - .03" THK COPPER, TIN PLATED
 B. HOUSING - BLUE VINYL
- DIMENSIONS IN BRACKETS ARE IN MILLIMETERS
- INSTALLATION TOOLS :
 A. PRESSES - CP-851, CP-860, CP-861
 B. APPLICATOR - CA-800
 C. DIE INSERTS - CD-800-2



LISTED
587H
E52164



CERTIFIED
LR31212

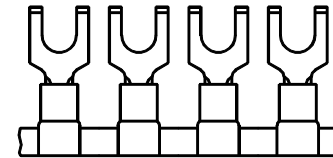

A41077_04

								PANDUIT CORP. TINLEY PARK, ILLINOIS					
04	12/00	ED		FILESPEC WAS: N41077AA_PCD_03	03774			TERMO 2PC CONTINUOUSLY MOLDED VINYL INSULATED, #16-14 BARREL, FLANGED FORKS					
03	11/95	ED		REVISIONS TO NOTES AND TABLE									
REV	DATE	BY	CHK	DESCRIPTION	ECN	PM	CUST	DRAWN BY	CHK'D	SCALE	NONE	DRAWING NO	A41077