



Chipsmall Limited consists of a professional team with an average of over 10 year of expertise in the distribution of electronic components. Based in Hongkong, we have already established firm and mutual-benefit business relationships with customers from,Europe,America and south Asia,supplying obsolete and hard-to-find components to meet their specific needs.

With the principle of "Quality Parts,Customers Priority,Honest Operation,and Considerate Service",our business mainly focus on the distribution of electronic components. Line cards we deal with include Microchip,ALPS,ROHM,Xilinx,Pulse,ON,Everlight and Freescale. Main products comprise IC,Modules,Potentiometer,IC Socket,Relay,Connector.Our parts cover such applications as commercial,industrial, and automotives areas.

We are looking forward to setting up business relationship with you and hope to provide you with the best service and solution. Let us make a better world for our industry!



Contact us

Tel: +86-755-8981 8866 Fax: +86-755-8427 6832

Email & Skype: info@chipsmall.com Web: www.chipsmall.com

Address: A1208, Overseas Decoration Building, #122 Zhenhua RD., Futian, Shenzhen, China



Type PVC Polyester and Polypropylene Film/Foil Capacitors

Polyester Film/Foil (100 V– 1000 V) and Polypropylene Film/Foil (1200 V - 2000 V)



The Type PVC is a sturdy film and extended foil construction ideal for bypass and coupling applications. Extended foil construction is as good as it gets for low DF and high current applications. The PVC is encapsulated in a rugged, flame retardant, epoxy coating with the leads crimped to provide secure seating on printed circuit boards.

Highlights

- ◆ RoHS Compliant
- ◆ Rugged epoxy case material meets UL94V0
- ◆ Film/foil polyester 100 – 1000 Vdc
- ◆ Film/foil polypropylene - 1200 Vdc to 2000 Vdc
- ◆ Non-inductively wound
- ◆ Non-polar
- ◆ Crimped leads for secure PC board insertion
- ◆ Lead material: tinned copper clad steel

Specifications

Capacitance Range: 0.001 μ F to 1.0 μ F

Capacitance Tolerance: \pm 10%

Voltage Range: Polyester: 100 Vdc to 1000 Vdc (70 Vac – 200 Vac 50/60 Hz)

Polypropylene: 1200 Vdc to 2000 Vdc (475 Vac – 500 Vac 50/60 Hz)

Operating Temperature Range: Polyester: -55° C to $+125^{\circ}$ C

Polypropylene: -55° C to $+105^{\circ}$ C

(Full rated voltage up to 85° C. Derate linearly to 50% rated voltage at max temperature)

Insulation Resistance (IR): Polyester: 100,000 $M\Omega$ for $\leq 0.25 \mu$ F, 25,000 $M\Omega \cdot \mu$ F for $\geq 0.25 \mu$ F

Polypropylene: 400,000 $M\Omega$ for $\leq 0.50 \mu$ F, 200,000 $M\Omega \cdot \mu$ F for $\geq 0.50 \mu$ F

After 2 minutes at rated voltage or 500V whichever is less. $+25^{\circ}$ C

0.75% max for <1200 V, 0.1% max for ≥ 1200 V. $+25^{\circ}$ C

Dissipation Factor (DF): 250% rated voltage for <1000 V, 200% rated voltage for ≥ 1000 V. 5 seconds, $+25^{\circ}$ C

Dielectric Withstand Voltage: 500 hours at $+85^{\circ}$ C, 1.5 times rated DC voltage

Life Test:



Complies with the EU Directive 2002/95/EC requirement restricting the use of Lead (Pb), Mercury (Hg), Cadmium (Cd), Hexavalent chromium (Cr(VI)), PolyBrominated Biphenyls (PBB) and PolyBrominated Diphenyl Ethers (PBDE).

Type PVC Polyester and Polypropylene Film/Foil Capacitors

Outline Drawing

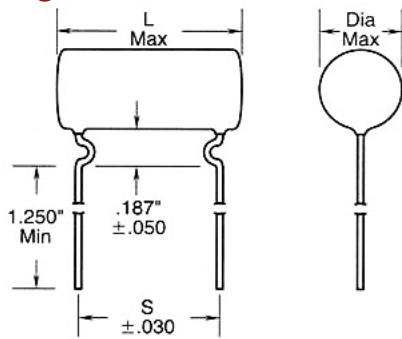

Lead Pull Test

Capacitor leads shall withstand a steady pull of 5 pounds applied radially to the capacitor body for 1 minute.

Lead Bend Test

Capacitor leads shall be bent without breakage below the lead crimp, first 90° in one direction then back to the original position and then 90° in the opposite direction.

Ratings

Catalog Part Number	Cap (µF)	Inches				Millimeters			
		L Max	Dia Max	S Lead Spacing	∅d	L Max	Dia Max	S Lead Spacing	∅d
100 Vdc / 70 Vac									
PVC1118	0.018	0.7	0.33	0.500	0.032	17.8	8.4	12.7	0.8
PVC1122	0.022	0.7	0.35	0.500	0.032	17.8	8.9	12.7	0.8
PVC1127	0.027	0.7	0.35	0.500	0.032	17.8	8.9	12.7	0.8
PVC1133	0.033	0.7	0.35	0.500	0.032	17.8	8.9	12.7	0.8
PVC114	0.040	0.7	0.35	0.500	0.032	17.8	8.9	12.7	0.8
PVC1147	0.047	0.7	0.35	0.500	0.032	17.8	8.9	12.7	0.8
PVC1156	0.056	0.7	0.38	0.500	0.032	17.8	9.7	12.7	0.8
PVC1168	0.068	0.7	0.38	0.500	0.032	17.8	9.7	12.7	0.8
PVC1182	0.082	0.9	0.40	0.688	0.032	22.9	10.2	17.5	0.8
PVC101	0.10	0.9	0.40	0.688	0.032	22.9	10.2	17.5	0.8
PVC1015	0.15	0.9	0.45	0.688	0.032	22.9	11.4	17.5	0.8
PVC1022	0.22	1.2	0.45	0.969	0.032	30.5	11.4	24.6	0.8
PVC1025	0.25	1.2	0.50	0.969	0.032	30.5	12.7	24.6	0.8
PVC1033	0.33	1.2	0.50	0.969	0.032	30.5	12.7	24.6	0.8
PVC1039	0.39	1.6	0.50	1.344	0.032	40.6	12.7	34.1	0.8
PVC1047	0.47	1.6	0.50	1.344	0.032	40.6	12.7	34.1	0.8
PVC105	0.50	1.6	0.60	1.344	0.032	40.6	15.2	34.1	0.8
PVC1056	0.56	1.6	0.60	1.344	0.032	40.6	15.2	34.1	0.8
PVC1068	0.68	1.6	0.60	1.344	0.032	40.6	15.2	34.1	0.8
PVC1082	0.82	1.6	0.65	1.344	0.032	40.6	16.5	34.1	0.8
PVC11	1.00	1.6	0.70	1.344	0.032	40.6	17.8	34.1	0.8
200 Vdc / 140 Vac									
PVC211	0.010	0.7	0.33	0.500	0.032	17.8	8.4	12.7	0.8
PVC2115	0.015	0.7	0.33	0.500	0.032	17.8	8.4	12.7	0.8
PVC2118	0.018	0.7	0.33	0.500	0.032	17.8	8.4	12.7	0.8
PVC212	0.020	0.7	0.33	0.500	0.032	17.8	8.4	12.7	0.8
PVC2122	0.022	0.7	0.33	0.500	0.032	17.8	8.4	12.7	0.8
PVC2133	0.033	0.9	0.38	0.688	0.032	22.9	9.7	17.5	0.8
PVC2139	0.039	0.9	0.38	0.688	0.032	22.9	9.7	17.5	0.8
PVC214	0.040	0.9	0.38	0.688	0.032	22.9	9.7	17.5	0.8
PVC2147	0.047	0.9	0.38	0.688	0.032	22.9	9.7	17.5	0.8
PVC215	0.050	0.9	0.38	0.688	0.032	22.9	9.7	17.5	0.8
PVC2156	0.056	1.2	0.38	0.969	0.032	30.5	9.7	24.6	0.8

Type PVC Polyester and Polypropylene Film/Foil Capacitors

RoHS Compliant

Catalog Part Number	Cap (µF)	Inches				Millimeters			
		L Max	Dia Max	S Lead Spacing	∅d	L Max	Dia Max	S Lead Spacing	∅d
200 Vdc / 140 Vac									
PVC2168	0.068	1.2	0.38	0.969	0.032	30.5	9.7	24.6	0.8
PVC2182	0.082	1.2	0.40	0.969	0.032	30.5	10.2	24.6	0.8
PVC201	0.10	1.2	0.40	0.969	0.032	30.5	10.2	24.6	0.8
PVC2015	0.15	1.2	0.45	0.969	0.032	30.5	11.4	24.6	0.8
PVC2022	0.22	1.2	0.50	0.969	0.032	30.5	12.7	24.6	0.8
PVC2025	0.25	1.2	0.50	0.969	0.032	30.5	12.7	24.6	0.8
PVC2027	0.27	1.6	0.47	1.344	0.032	40.6	11.9	34.1	0.8
PVC2033	0.33	1.6	0.47	1.344	0.032	40.6	11.9	34.1	0.8
PVC2047	0.47	1.6	0.56	1.344	0.032	40.6	14.2	34.1	0.8
PVC205	0.50	1.6	0.56	1.344	0.032	40.6	14.2	34.1	0.8
400 Vdc / 200 Vac									
PVC421	0.0010	0.7	0.30	0.500	0.032	17.8	7.6	12.7	0.8
PVC4222	0.0022	0.7	0.30	0.500	0.032	17.8	7.6	12.7	0.8
PVC4233	0.0033	0.7	0.30	0.500	0.032	17.8	7.6	12.7	0.8
PVC4247	0.0047	0.7	0.30	0.500	0.032	17.8	7.6	12.7	0.8
PVC4268	0.0068	0.7	0.33	0.500	0.032	17.8	8.4	12.7	0.8
PVC411	0.010	0.7	0.35	0.500	0.032	17.8	8.9	12.7	0.8
PVC412	0.020	0.9	0.39	0.688	0.032	22.9	9.9	17.5	0.8
PVC4133	0.033	0.9	0.40	0.688	0.032	22.9	10.2	17.5	0.8
PVC4147	0.047	1.2	0.40	0.969	0.032	30.5	10.2	24.6	0.8
PVC415	0.050	1.2	0.45	0.969	0.032	30.5	11.4	24.6	0.8
PVC4156	0.056	1.2	0.45	0.969	0.032	30.5	11.4	24.6	0.8
PVC4168	0.068	1.2	0.45	0.969	0.032	30.5	11.4	24.6	0.8
PVC4182	0.082	1.2	0.52	0.969	0.032	30.5	13.2	24.6	0.8
PVC401	0.10	1.2	0.53	0.969	0.032	30.5	13.5	24.6	0.8
PVC4015	0.15	1.2	0.57	0.969	0.032	30.5	14.5	24.6	0.8
PVC4018	0.18	1.6	0.60	1.344	0.032	40.6	15.2	34.1	0.8
PVC4022	0.22	1.6	0.60	1.344	0.032	40.6	15.2	34.1	0.8
PVC4025	0.25	1.6	0.65	1.344	0.032	40.6	16.5	34.1	0.8
PVC4033	0.33	1.6	0.65	1.344	0.032	40.6	16.5	34.1	0.8
PVC4039	0.39	1.6	0.72	1.344	0.032	40.6	18.3	34.1	0.8
PVC4047	0.47	1.6	0.80	1.344	0.032	40.6	20.3	34.1	0.8
600 Vdc / 200 Vac									
PVC621	0.0010	0.7	0.30	0.500	0.032	17.8	7.6	12.7	0.8
PVC6212	0.0012	0.7	0.33	0.500	0.032	17.8	8.4	12.7	0.8
PVC6215	0.0015	0.7	0.33	0.500	0.032	17.8	8.4	12.7	0.8
PVC6218	0.0018	0.7	0.33	0.500	0.032	17.8	8.4	12.7	0.8
PVC622	0.0020	0.7	0.33	0.500	0.032	17.8	8.4	12.7	0.8
PVC6222	0.0022	0.7	0.33	0.500	0.032	17.8	8.4	12.7	0.8
PVC6225	0.0025	0.7	0.34	0.500	0.032	17.8	8.6	12.7	0.8
PVC6227	0.0027	0.7	0.35	0.500	0.032	17.8	8.9	12.7	0.8
PVC623	0.0030	0.7	0.35	0.500	0.032	17.8	8.9	12.7	0.8
PVC6233	0.0033	0.7	0.35	0.500	0.032	17.8	8.9	12.7	0.8
PVC6239	0.0039	0.7	0.38	0.500	0.032	17.8	9.7	12.7	0.8
PVC624	0.0040	0.7	0.38	0.500	0.032	17.8	9.7	12.7	0.8
PVC6247	0.0047	0.7	0.38	0.500	0.032	17.8	9.7	12.7	0.8
PVC625	0.0050	0.7	0.38	0.500	0.032	17.8	9.7	12.7	0.8
PVC6256	0.0056	0.7	0.40	0.500	0.032	17.8	10.2	12.7	0.8

Type PVC Polyester and Polypropylene Film/Foil Capacitors

RoHS Compliant

Catalog Part Number	Cap (μ F)	Inches				Millimeters			
		L Max	Dia Max	S Lead Spacing	\varnothing d	L Max	Dia Max	S Lead Spacing	\varnothing d
600 Vdc / 200 Vac									
PVC626	0.0060	0.7	0.40	0.500	0.032	17.8	10.2	12.7	0.8
PVC6268	0.0068	0.7	0.40	0.500	0.032	17.8	10.2	12.7	0.8
PVC6275	0.0075	0.7	0.40	0.500	0.032	17.8	10.2	12.7	0.8
PVC628	0.0080	0.9	0.40	0.688	0.032	22.9	10.2	17.5	0.8
PVC6282	0.0082	0.9	0.40	0.688	0.032	22.9	10.2	17.5	0.8
PVC611	0.010	0.9	0.40	0.688	0.032	22.9	10.2	17.5	0.8
PVC6112	0.012	0.9	0.40	0.688	0.032	22.9	10.2	17.5	0.8
PVC6115	0.015	0.9	0.40	0.688	0.032	22.9	10.2	17.5	0.8
PVC6118	0.018	0.9	0.45	0.688	0.032	22.9	11.4	17.5	0.8
PVC612	0.020	0.9	0.45	0.688	0.032	22.9	11.4	17.5	0.8
PVC6122	0.022	0.9	0.45	0.688	0.032	22.9	11.4	17.5	0.8
PVC6125	0.025	0.9	0.45	0.688	0.032	22.9	11.4	17.5	0.8
PVC6127	0.027	1.2	0.45	0.969	0.032	30.5	11.4	24.6	0.8
PVC613	0.030	1.2	0.45	0.969	0.032	30.5	11.4	24.6	0.8
PVC6133	0.033	1.2	0.45	0.969	0.032	30.5	11.4	24.6	0.8
PVC6139	0.039	1.2	0.56	0.969	0.032	30.5	14.2	24.6	0.8
PVC614	0.040	1.2	0.56	0.969	0.032	30.5	14.2	24.6	0.8
PVC6147	0.047	1.2	0.56	0.969	0.032	30.5	14.2	24.6	0.8
PVC615	0.050	1.2	0.56	0.969	0.032	30.5	14.2	24.6	0.8
PVC6156	0.056	1.2	0.60	0.969	0.032	30.5	15.2	24.6	0.8
PVC6168	0.068	1.2	0.60	0.969	0.032	30.5	15.2	24.6	0.8
PVC6182	0.082	1.2	0.65	0.969	0.032	30.5	16.5	24.6	0.8
PVC601	0.10	1.2	0.65	0.969	0.032	30.5	16.5	24.6	0.8
PVC6012	0.12	1.6	0.70	1.344	0.032	40.6	17.8	34.1	0.8
PVC6015	0.15	1.6	0.70	1.344	0.032	40.6	17.8	34.1	0.8
PVC6018	0.18	1.6	0.80	1.344	0.032	40.6	20.3	34.1	0.8
PVC602	0.20	1.6	0.80	1.344	0.032	40.6	20.3	34.1	0.8
PVC6022	0.22	1.6	0.80	1.344	0.032	40.6	20.3	34.1	0.8
PVC6025	0.25	1.6	0.80	1.344	0.032	40.6	20.3	34.1	0.8
PVC6033	0.33	1.81	0.89	1.531	0.032	46.0	22.6	38.9	0.8
1000 Vdc / 200 Vac									
PVC1021	0.0010	0.7	0.33	0.500	0.032	17.8	8.4	12.7	0.8
PVC10215	0.0015	0.7	0.33	0.500	0.032	17.8	8.4	12.7	0.8
PVC10218	0.0018	0.7	0.35	0.500	0.032	17.8	8.9	12.7	0.8
PVC10222	0.0022	0.7	0.35	0.500	0.032	17.8	8.9	12.7	0.8
PVC10233	0.0033	0.9	0.35	0.688	0.032	22.9	8.9	17.5	0.8
PVC10247	0.0047	0.9	0.40	0.688	0.032	22.9	10.2	17.5	0.8
PVC10256	0.0056	0.9	0.43	0.688	0.032	22.9	10.9	17.5	0.8
PVC10268	0.0068	0.9	0.43	0.688	0.032	22.9	10.9	17.5	0.8
PVC10282	0.0082	0.9	0.48	0.688	0.032	22.9	12.2	17.5	0.8
PVC1011	0.010	0.9	0.48	0.688	0.032	22.9	12.2	17.5	0.8
PVC10115	0.015	1.2	0.48	0.969	0.032	30.5	12.2	24.6	0.8
PVC10118	0.018	1.2	0.58	0.969	0.032	30.5	14.7	24.6	0.8
PVC10122	0.022	1.2	0.58	0.969	0.032	30.5	14.7	24.6	0.8
PVC10127	0.027	1.2	0.65	0.969	0.032	30.5	16.5	24.6	0.8
PVC10133	0.033	1.2	0.65	0.969	0.032	30.5	16.5	24.6	0.8

Type PVC Polyester and Polypropylene Film/Foil Capacitors

RoHS Compliant

Catalog Part Number	Cap (μ F)	Inches				Millimeters			
		L Max	Dia Max	S Lead Spacing	\varnothing d	L Max	Dia Max	S Lead Spacing	\varnothing d
1000 Vdc / 200 Vac									
PVC10139	0.039	1.6	0.65	1.344	0.032	40.6	16.5	34.1	0.8
PVC10147	0.047	1.6	0.65	1.344	0.032	40.6	16.5	34.1	0.8
PVC10156	0.056	1.6	0.75	1.344	0.032	40.6	19.1	34.1	0.8
PVC10168	0.068	1.6	0.75	1.344	0.032	40.6	19.1	34.1	0.8
PVC10182	0.082	1.6	0.85	1.344	0.032	40.6	21.6	34.1	0.8
PVC10010	0.100	1.6	0.85	1.344	0.032	40.6	21.6	34.1	0.8
1200 Vdc / 475 Vac									
PVC1221	0.0010	1.25	0.42	0.969	0.032	31.8	10.7	24.6	0.8
PVC12212	0.0012	1.25	0.42	0.969	0.032	31.8	10.7	24.6	0.8
PVC12215	0.0015	1.25	0.42	0.969	0.032	31.8	10.7	24.6	0.8
PVC12218	0.0018	1.25	0.42	0.969	0.032	31.8	10.7	24.6	0.8
PVC12222	0.0022	1.25	0.42	0.969	0.032	31.8	10.7	24.6	0.8
PVC12227	0.0027	1.25	0.42	0.969	0.032	31.8	10.7	24.6	0.8
PVC12233	0.0033	1.25	0.42	0.969	0.032	31.8	10.7	24.6	0.8
PVC12239	0.0039	1.25	0.42	0.969	0.032	31.8	10.7	24.6	0.8
PVC12247	0.0047	1.25	0.42	0.969	0.032	31.8	10.7	24.6	0.8
PVC12256	0.0056	1.25	0.44	0.969	0.032	31.8	11.2	24.6	0.8
PVC12268	0.0068	1.25	0.47	0.969	0.032	31.8	11.9	24.6	0.8
PVC12282	0.0082	1.25	0.50	0.969	0.032	31.8	12.7	24.6	0.8
PVC1211	0.010	1.25	0.53	0.969	0.032	31.8	13.5	24.6	0.8
PVC12112	0.012	1.25	0.57	0.969	0.032	31.8	14.5	24.6	0.8
PVC12115	0.015	1.25	0.61	0.969	0.032	31.8	15.5	24.6	0.8
PVC12118	0.018	1.65	0.56	1.344	0.032	41.9	14.2	34.1	0.8
PVC12122	0.022	1.65	0.60	1.344	0.032	41.9	15.2	34.1	0.8
PVC12127	0.027	1.65	0.65	1.344	0.032	41.9	16.5	34.1	0.8
PVC12133	0.033	1.65	0.70	1.344	0.032	41.9	17.8	34.1	0.8
PVC12139	0.039	1.65	0.74	1.344	0.032	41.9	18.8	34.1	0.8
PVC12147	0.047	1.65	0.80	1.344	0.032	41.9	20.3	34.1	0.8
1600 Vdc / 475 Vac									
PVC1621	0.0010	1.25	0.42	0.969	0.032	31.8	10.7	24.6	0.8
PVC16215	0.0015	1.25	0.42	0.969	0.032	31.8	10.7	24.6	0.8
PVC16222	0.0022	1.25	0.42	0.969	0.032	31.8	10.7	24.6	0.8
PVC16227	0.0027	1.25	0.42	0.969	0.032	31.8	10.7	24.6	0.8
PVC1623	0.0030	1.25	0.42	0.969	0.032	31.8	10.7	24.6	0.8
PVC16233	0.0033	1.25	0.42	0.969	0.032	31.8	10.7	24.6	0.8
PVC1624	0.0040	1.25	0.42	0.969	0.032	31.8	10.7	24.6	0.8
PVC16247	0.0047	1.25	0.42	0.969	0.032	31.8	10.7	24.6	0.8
PVC1625	0.0050	1.25	0.42	0.969	0.032	31.8	10.7	24.6	0.8
PVC1626	0.0060	1.25	0.44	0.969	0.032	31.8	11.2	24.6	0.8
PVC16268	0.0068	1.25	0.47	0.969	0.032	31.8	11.9	24.6	0.8
PVC1627	0.0070	1.25	0.50	0.969	0.032	31.8	12.7	24.6	0.8
PVC16275	0.0075	1.25	0.50	0.969	0.032	31.8	12.7	24.6	0.8
PVC1628	0.0080	1.25	0.50	0.969	0.032	31.8	12.7	24.6	0.8
PVC16282	0.0082	1.25	0.50	0.969	0.032	31.8	12.7	24.6	0.8

Type PVC Polyester and Polypropylene Film/Foil Capacitors

RoHS Compliant

Catalog Part Number	Cap (μF)	Inches				Millimeters			
		L Max	Dia Max	S Lead Spacing	∅d	L Max	Dia Max	S Lead Spacing	∅d
1600 Vdc / 475 Vac									
PVC1611	0.010	1.25	0.53	0.969	0.032	31.8	13.5	24.6	0.8
PVC16115	0.015	1.25	0.61	1.344	0.032	33.8	15.5	34.1	0.8
PVC1612	0.020	1.65	0.60	1.344	0.032	41.9	15.2	34.1	0.8
PVC16122	0.022	1.65	0.60	1.344	0.032	41.9	15.2	34.1	0.8
PVC16133	0.033	1.65	0.70	1.344	0.032	41.9	17.8	34.1	0.8
PVC16147	0.047	1.65	0.80	1.344	0.032	41.9	20.3	34.1	0.8
PVC1615	0.050	1.65	0.85	1.344	0.032	41.9	21.6	34.1	0.8
2000 Vdc / 500 Vac									
PVC2X21	0.0010	1.25	0.33	0.969	0.032	31.8	8.4	24.6	0.8
PVC2X212	0.0012	1.25	0.34	0.969	0.032	31.8	8.6	24.6	0.8
PVC2X215	0.0015	1.25	0.36	0.969	0.032	31.8	9.1	24.6	0.8
PVC2X218	0.0018	1.25	0.38	0.969	0.032	31.8	9.7	24.6	0.8
PVC2X222	0.0022	1.25	0.39	0.969	0.032	31.8	9.9	24.6	0.8
PVC2X227	0.0027	1.25	0.42	0.969	0.032	31.8	10.7	24.6	0.8
PVC2X233	0.0033	1.25	0.44	0.969	0.032	31.8	11.2	24.6	0.8
PVC2X239	0.0039	1.25	0.47	0.969	0.032	31.8	11.9	24.6	0.8
PVC2X247	0.0047	1.25	0.5	0.969	0.032	31.8	12.7	24.6	0.8
PVC2X256	0.0056	1.25	0.53	0.969	0.032	31.8	13.5	24.6	0.8
PVC2X268	0.0068	1.25	0.56	0.969	0.032	31.8	14.2	24.6	0.8
PVC2X282	0.0082	1.25	0.60	0.969	0.032	31.8	15.2	24.6	0.8
PVC2X11	0.0100	1.25	0.65	0.969	0.032	31.8	16.5	24.6	0.8
PVC2X112	0.0120	1.65	0.58	1.344	0.032	41.9	14.7	34.1	0.8
PVC2X115	0.0150	1.65	0.63	1.344	0.032	41.9	16.0	34.1	0.8
PVC2X118	0.018	1.65	0.67	1.344	0.032	41.9	17.0	34.1	0.8
PVC2X122	0.022	1.65	0.73	1.344	0.032	41.9	18.5	34.1	0.8
PVC2X127	0.027	1.65	0.78	1.344	0.032	41.9	19.8	34.1	0.8
PVC2X133	0.033	1.65	0.85	1.344	0.032	41.9	21.6	34.1	0.8

Part Numbering System

PVC	4	01
Series	Voltage	Capacitance
PVC	1 = 100 V	21 = .001 μF
	2 = 200V	11 = .01 μF
	4 = 400V	01 = .1 μF
	6 = 600V	1 = 1.0 μF
	10 = 1000 V	
	12 = 1200 V	
	16 = 1600 V	
	2X = 2000 V	

Type PVC Polyester and Polypropylene Film/Foil Capacitors

Notice and Disclaimer: All product drawings, descriptions, specifications, statements, information and data (collectively, the "Information") in this datasheet or other publication are subject to change. The customer is responsible for checking, confirming and verifying the extent to which the Information contained in this datasheet or other publication is applicable to an order at the time the order is placed. All Information given herein is believed to be accurate and reliable, but it is presented without any guarantee, warranty, representation or responsibility of any kind, expressed or implied. Statements of suitability for certain applications are based on the knowledge that the Cornell Dubilier company providing such statements ("Cornell Dubilier") has of operating conditions that such Cornell Dubilier company regards as typical for such applications, but are not intended to constitute any guarantee, warranty or representation regarding any such matter – and Cornell Dubilier specifically and expressly disclaims any guarantee, warranty or representation concerning the suitability for a specific customer application, use, storage, transportation, or operating environment. The Information is intended for use only by customers who have the requisite experience and capability to determine the correct products for their application. Any technical advice inferred from this Information or otherwise provided by Cornell Dubilier with reference to the use of any Cornell Dubilier products is given gratis (unless otherwise specified by Cornell Dubilier), and Cornell Dubilier assumes no obligation or liability for the advice given or results obtained. Although Cornell Dubilier strives to apply the most stringent quality and safety standards regarding the design and manufacturing of its products, in light of the current state of the art, isolated component failures may still occur. Accordingly, customer applications which require a high degree of reliability or safety should employ suitable designs or other safeguards (such as installation of protective circuitry or redundancies or other appropriate protective measures) in order to ensure that the failure of an electrical component does not result in a risk of personal injury or property damage. Although all product-related warnings, cautions and notes must be observed, the customer should not assume that all safety measures are indicated in such warnings, cautions and notes, or that other safety measures may not be required.

Obsolete
See 418P or 715P