



Chipsmall Limited consists of a professional team with an average of over 10 year of expertise in the distribution of electronic components. Based in Hongkong, we have already established firm and mutual-benefit business relationships with customers from,Europe,America and south Asia,supplying obsolete and hard-to-find components to meet their specific needs.

With the principle of “Quality Parts,Customers Priority,Honest Operation,and Considerate Service”,our business mainly focus on the distribution of electronic components. Line cards we deal with include Microchip,ALPS,ROHM,Xilinx,Pulse,ON,Everlight and Freescale. Main products comprise IC,Modules,Potentiometer,IC Socket,Relay,Connector.Our parts cover such applications as commercial,industrial, and automotives areas.

We are looking forward to setting up business relationship with you and hope to provide you with the best service and solution. Let us make a better world for our industry!



## Contact us

Tel: +86-755-8981 8866 Fax: +86-755-8427 6832

Email & Skype: info@chipsmall.com Web: www.chipsmall.com

Address: A1208, Overseas Decoration Building, #122 Zhenhua RD., Futian, Shenzhen, China



## 1. General description

The PX1011B is a high-performance, low-power, single-lane PCI Express electrical PHYsical layer (PHY) that handles the low level PCI Express protocol and signaling. The PX1011B PCI Express PHY is compliant to the *PCI Express Base Specification, Rev. 1.0a*, and *Rev. 1.1*. The PX1011B includes features such as Clock and Data Recovery (CDR), data serialization and de-serialization, 8b/10b encoding, analog buffers, elastic buffer and receiver detection, and provides superior performance to the Media Access Control (MAC) layer devices.

The PX1011B is a 2.5 Gbit/s PCI Express PHY with 8-bit data PXPIPE interface. Its PXPIPE interface is a superset of the PHY Interface for the PCI Express (PIPE) specification, enhanced and adapted for off-chip applications with the introduction of a source synchronous clock for transmit and receive data. The 8-bit data interface operates at 250 MHz with SSTL\_2 signaling. The SSTL\_2 signaling is compatible with the I/O interfaces available in FPGA products.

The PX1011B PCI Express PHY supports advanced power management functions. The PX1011BI is for the industrial temperature range (–40 °C to +85 °C). Automotive AEC-Q100 compliant version PX1011B-EL1/Q900 is available.

## 2. Features and benefits

### 2.1 PCI Express interface

- Compliant to *PCI Express Base Specification 1.1*
- Single PCI Express 2.5 Gbit/s lane
- Data and clock recovery from serial stream
- Serializer and De-serializer (SerDes)
- Receiver detection
- 8b/10b coding and decoding, elastic buffer and word alignment
- Supports loopback
- Supports direct disparity control for use in transmitting compliance pattern
- Supports lane polarity inversion
- Low jitter and Bit Error Rate (BER)

### 2.2 PHY/MAC interface

- Based on Intel PHY Interface for PCI Express architecture v1.0 (PIPE)
- Adapted for off-chip with additional synchronous clock signals (PXPIPE)
- 8-bit parallel data interface for transmit and receive at 250 MHz
- 2.5 V SSTL\_2 class I signaling

## 2.3 JTAG interface

- JTAG (IEEE 1149.1) boundary scan interface
- Built-In Self Test (BIST) controller tests SerDes and I/O blocks at speed
- 3.3 V CMOS signaling

## 2.4 Power management

- Dissipates < 300 mW in L0 normal mode
- Support power management of L0, L0s and L1

## 2.5 Clock

- 100 MHz external reference clock with  $\pm 300$  ppm tolerance
- Supports spread spectrum clock to reduce EMI
- On-chip reference clock termination

## 2.6 Miscellaneous

- LFBGA81 leaded or lead-free packages
- Operating ambient temperature
  - ◆ Commercial: 0 °C to +70 °C
  - ◆ Industrial: -40 °C to +85 °C
- ESD protection voltage for Human Body Model (HBM): 2000 V

## 3. Quick reference data

Table 1. Quick reference data

| Symbol                | Parameter                 | Conditions                        | Min   | Typ | Max    | Unit |
|-----------------------|---------------------------|-----------------------------------|-------|-----|--------|------|
| V <sub>DDD1</sub>     | digital supply voltage 1  | for JTAG I/O                      | 3.0   | 3.3 | 3.6    | V    |
| V <sub>DDD2</sub>     | digital supply voltage 2  | for SSTL_2 I/O                    | 2.3   | 2.5 | 2.7    | V    |
| V <sub>DDD3</sub>     | digital supply voltage 3  | for core                          | 1.15  | 1.2 | 1.3    | V    |
| V <sub>DD</sub>       | supply voltage            | for high-speed serial I/O and PVT | 1.15  | 1.2 | 1.3    | V    |
| V <sub>DDA1</sub>     | analog supply voltage 1   | for serializer                    | 1.15  | 1.2 | 1.3    | V    |
| V <sub>DDA2</sub>     | analog supply voltage 2   | for serializer                    | 3.0   | 3.3 | 3.6    | V    |
| f <sub>clk(ref)</sub> | reference clock frequency |                                   | 99.97 | 100 | 100.03 | MHz  |
| T <sub>amb</sub>      | ambient temperature       | operating                         |       |     |        |      |
|                       |                           | commercial                        | 0     | -   | +70    | °C   |
|                       |                           | industrial                        | -40   | -   | +85    | °C   |



## 4. Ordering information

Table 2. Ordering information

| Type number                     | Solder process                        | Package |  |          |
|---------------------------------|---------------------------------------|---------|--|----------|
|                                 |                                       | Name    | Description  | Version  |
| PX1011B-EL1/G                   | Pb-free (SnAgCu solder ball compound) | LFBGA81 | plastic low profile fine-pitch ball grid array package; 81 balls; body 9 × 9 × 1.05 mm | SOT643-1 |
| PX1011B-EL1/N                   | SnPb solder ball compound             | LFBGA81 | plastic low profile fine-pitch ball grid array package; 81 balls; body 9 × 9 × 1.05 mm | SOT643-1 |
| PX1011BI-EL1/G                  | Pb-free (SnAgCu solder ball compound) | LFBGA81 | plastic low profile fine-pitch ball grid array package; 81 balls; body 9 × 9 × 1.05 mm | SOT643-1 |
| PX1011B-EL1/Q900 <sup>[1]</sup> | Pb-free (SnAgCu solder ball compound) | LFBGA81 | plastic low profile fine-pitch ball grid array package; 81 balls; body 9 × 9 × 1.05 mm | SOT643-1 |

[1] PX1011B-EL1/Q900 is AEC-Q100 compliant. Contact [i2c.support@nxp.com](mailto:i2c.support@nxp.com) for PPAP.

## 5. Marking

Table 3. Leaded package marking

| Line | Marking       | Description  |
|------|---------------|--|
| A    | PX1011B-EL1/N | full basic type number   |
| B    | xxxxxxx       | diffusion lot number   |
| C    | 2PNyyww       | manufacturing code:<br>2 = diffusion site<br>P = assembly site<br>N = leaded<br>yy = year code<br>ww = week code |

Table 4. Lead-free package marking

| Line | Marking  | Description   |
|------|--|---|
| A    | PX1011B-EL1/G<br>PX1011BI-EL1/G <sup>[1]</sup><br>PX1011B-EL1/Q <sup>[1]</sup> | full basic type number  |
| B    | xxxxxxx  | diffusion lot number  |
| C    | 2PGyyww  | manufacturing code:<br>2 = diffusion site<br>P = assembly site<br>G = lead-free<br>yy = year code<br>ww = week code |

[1] Industrial temperature range.

## 6. Block diagram

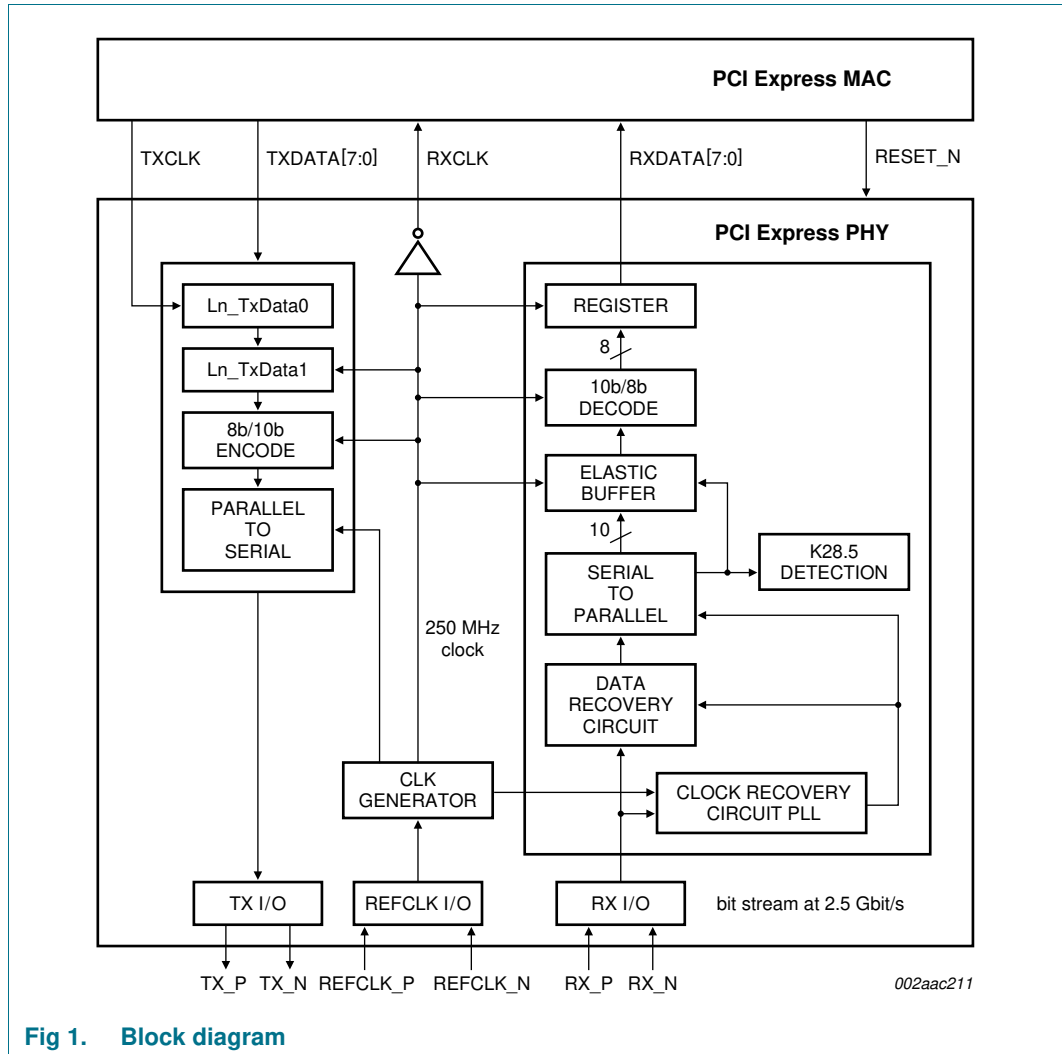
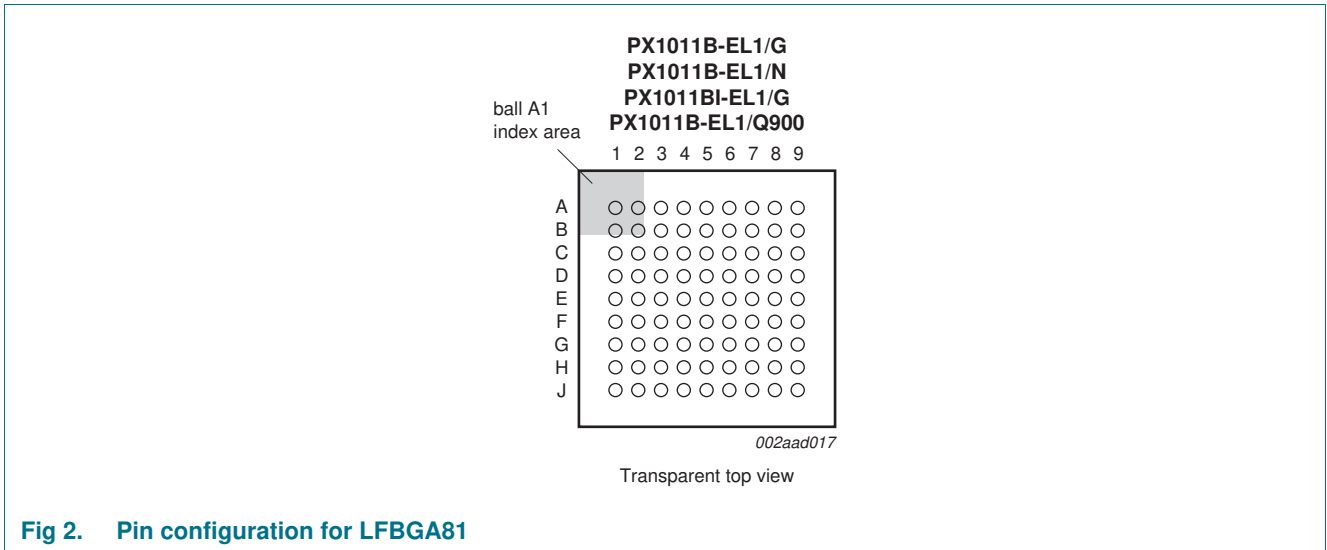

Fig 1. Block diagram

## 7. Pinning information

### 7.1 Pinning



**Fig 2. Pin configuration for LFBGA81**

|   | 1               | 2               | 3                 | 4                 | 5                 | 6                 | 7                 | 8               | 9         |
|---|-----------------|-----------------|-------------------|-------------------|-------------------|-------------------|-------------------|-----------------|-----------|
| A | V <sub>SS</sub> | RXIDLE          | RXDATA6           | RXDATA4           | RXDATA3           | RXDATA1           | RXDATAK           | RXCLK           | RXSTATUS0 |
| B | REFCLK_P        | V <sub>SS</sub> | RXDATA7           | RXDATA5           | V <sub>SS</sub>   | RXDATA2           | RXDATA0           | V <sub>SS</sub> | RXSTATUS1 |
| C | REFCLK_N        | V <sub>SS</sub> | V <sub>DDD2</sub> | V <sub>SS</sub>   | V <sub>DDD2</sub> | V <sub>SS</sub>   | V <sub>DDD2</sub> | RXVALID         | RXSTATUS2 |
| D | V <sub>SS</sub> | V <sub>SS</sub> | V <sub>DD</sub>   | V <sub>DDA2</sub> | V <sub>DDA1</sub> | PVT               | V <sub>SS</sub>   | PHYSTATUS       | TXDATA0   |
| E | RX_P            | V <sub>SS</sub> | V <sub>DDD1</sub> | TMS               | V <sub>DDD1</sub> | V <sub>DDD3</sub> | V <sub>DDD2</sub> | V <sub>SS</sub> | TXDATA1   |
| F | RX_N            | V <sub>SS</sub> | TCK               | TRST_N            | V <sub>DDD3</sub> | V <sub>DDD3</sub> | V <sub>SS</sub>   | TXDATA3         | TXDATA2   |
| G | V <sub>SS</sub> | V <sub>SS</sub> | TDI               | V <sub>SS</sub>   | V <sub>DDD2</sub> | V <sub>SS</sub>   | V <sub>DDD2</sub> | TXDATA5         | TXDATA4   |
| H | TX_P            | V <sub>SS</sub> | TDO               | TXIDLE            | V <sub>SS</sub>   | PWRDWN0           | RXDET_LOOPB       | V <sub>SS</sub> | TXDATA6   |
| J | TX_N            | VREFS           | RESET_N           | RXPOL             | TXCOMP            | PWRDWN1           | TXDATAK           | TXCLK           | TXDATA7   |

002aad018

Transparent top view.

**Fig 3. Ball mapping**

## 7.2 Pin description

The PHY input and output pins are described in [Table 5](#) to [Table 12](#). Note that input and output is defined from the perspective of the PHY. Thus a signal on a pin described as an output is driven by the PHY and a signal on a pin described as an input is received by the PHY. A basic description of each pin is provided.

**Table 5. PCI Express serial data lines**

| Symbol | Pin | Type   | Signaling | Description  |
|--------|-----|--------|-----------|--|
| RX_P   | E1  | input  | PCIe I/O  | differential input receive pair with 50 $\Omega$ on-chip termination   |
| RX_N   | F1  | input  | PCIe I/O  |  |
| TX_P   | H1  | output | PCIe I/O  | differential output transmit pair with 50 $\Omega$ on-chip termination |
| TX_N   | J1  | output | PCIe I/O  |  |

**Table 6. PXPIPE interface transmit data signals**

| Symbol      | Pin                               | Type  | Signaling | Description  |
|-------------|-----------------------------------|-------|-----------|--|
| TXDATA[7:0] | J9, H9, G8, G9,<br>F8, F9, E9, D9 | input | SSTL_2    | 8-bit transmit data input from the MAC to the PHY                                      |
| TXDATAK     | J7                                | input | SSTL_2    | selection input for the symbols of transmit data; LOW = data byte; HIGH = control byte |

**Table 7. PXPIPE interface receive data signals**

| Symbol      | Pin                               | Type   | Signaling | Description  |
|-------------|-----------------------------------|--------|-----------|--|
| RXDATA[7:0] | B3, A3, B4, A4,<br>A5, B6, A6, B7 | output | SSTL_2    | 8-bit receive data output from the PHY to the MAC                                      |
| RXDATAK     | A7                                | output | SSTL_2    | selection output for the symbols of receive data; LOW = data byte; HIGH = control byte |

**Table 8. PXPIPE interface command signals**

| Symbol      | Pin | Type  | Signaling | Description   |
|-------------|-----|-------|-----------|---|
| RXDET_LOOPB | H7  | input | SSTL_2    | used to tell the PHY to begin a receiver detection operation or to begin loopback; LOW = reset state  |
| TXIDLE      | H4  | input | SSTL_2    | forces TX output to electrical idle. TXIDLE should be asserted while in power states P0s and P1.  |
| TXCOMP      | J5  | input | SSTL_2    | used when transmitting the compliance pattern; HIGH-level sets the running disparity to negative  |
| RXPOL       | J4  | input | SSTL_2    | signals the PHY to perform a polarity inversion on the receive data; LOW = PHY does no polarity inversion; HIGH = PHY does polarity inversion |
| RESET_N     | J3  | input | SSTL_2    | PHY reset input; active LOW   |
| PWRDWN0     | H6  | input | SSTL_2    | transceiver power-up and power-down inputs (see <a href="#">Table 13</a> ); 0x2 = reset state   |
| PWRDWN1     | J6  | input | SSTL_2    |   |

Table 9. PXPIPE interface status signals

| Symbol    | Pin | Type   | Signaling | Description   |
|-----------|-----|--------|-----------|---|
| RXVALID   | C8  | output | SSTL_2    | indicates symbol lock and valid data on RX_DATA and RX_DATAK  |
| PHYSTATUS | D8  | output | SSTL_2    | used to communicate completion of several PHY functions including power management state transitions and receiver detection |
| RXIDLE    | A2  | output | SSTL_2    | indicates receiver detection of an electrical idle; this is an asynchronous signal  |
| RXSTATUS0 | A9  | output | SSTL_2    | encodes receiver status and error codes for the received data stream and receiver detection (see <a href="#">Table 15</a> ) |
| RXSTATUS1 | B9  | output | SSTL_2    |   |
| RXSTATUS2 | C9  | output | SSTL_2    |   |

Table 10. Clock and reference signals

| Symbol   | Pin | Type   | Signaling  | Description  |
|----------|-----|--------|------------|--|
| TXCLK    | J8  | input  | SSTL_2     | source synchronous 250 MHz transmit clock input from MAC. All input data and signals to the PHY are synchronized to this clock.  |
| RXCLK    | A8  | output | SSTL_2     | source synchronous 250 MHz clock output for received data and status signals bound for the MAC.  |
| REFCLK_P | B1  | input  | PCIe I/O   | 100 MHz reference clock input. This is the spread spectrum source clock for PCI Express. Differential pair input with 50 $\Omega$ on-chip termination.                               |
| REFCLK_N | C1  | input  | PCIe I/O   |  |
| PVT      | D6  | -      | analog I/O | input or output to create a compensation signal internally that will adjust the I/O pads characteristics as PVT drifts. Connect to V <sub>DD</sub> through a 49.9 $\Omega$ resistor. |
| VREFS    | J2  | input  |            | reference voltage input for SSTL_2 class I signaling. Connect to 1.25 V.   |

Table 11. 3.3 V JTAG signals

| Symbol | Pin | Type   | Signaling  | Description   |
|--------|-----|--------|------------|---|
| TMS    | E4  | input  | 3.3 V CMOS | test mode select input                              |
| TRST_N | F4  | input  | 3.3 V CMOS | test reset input for the JTAG interface; active LOW |
| TCK    | F3  | input  | 3.3 V CMOS | test clock input for the JTAG interface             |
| TDI    | G3  | input  | 3.3 V CMOS | test data input                                     |
| TDO    | H3  | output | 3.3 V CMOS | test data output                                    |



**Table 12. PCI Express PHY power supplies**

| Symbol            | Pin  | Type   | Signaling | Description   |
|-------------------|--|--------|-----------|---|
| V <sub>DDA1</sub> | D5   | power  |           | 1.2 V analog power supply for serializer and de-serializer            |
| V <sub>DDA2</sub> | D4   | power  |           | 3.3 V analog power supply for serializer and de-serializer            |
| V <sub>DD1</sub>  | E3, E5   | power  |           | 3.3 V power supply for JTAG I/O                                       |
| V <sub>DD2</sub>  | C3, C5, C7, E7, G5, G7   | power  |           | 2.5 V power supply for SSTL_2 I/O                                     |
| V <sub>DD3</sub>  | E6, F5, F6   | power  |           | 1.2 V power supply for core   |
| V <sub>DD</sub>   | D3   | power  |           | 1.2 V power supply for high-speed serial PCI Express I/O pads and PVT |
| V <sub>SS</sub>   | A1, B2, B5, B8, C2, C4, C6, D1, D2, D7, E2, E8, F2, F7, G1, G2, G4, G6, H2, H5, H8 | ground |           | ground  |

## 8. Functional description

The main function of the PHY is to convert digital data into electrical signals and vice versa. The PCI Express PHY handles the low level PCI Express protocol and signaling. The PX1011B PCI Express PHY consists of the Physical Coding Sub-layer (PCS), a Serializer and De-serializer (SerDes) and a set of I/Os (pads). The PCI Express PHY handles the low level PCI Express protocol and signaling. This includes features such as Clock and Data Recovery (CDR), data serialization and de-serialization, 8b/10b encoding, analog buffers, elastic buffer and receiver detection.

The PXPIPE interface between the MAC and PX1011B is a superset of the PHY Interface for the PCI Express (PIPE) specification. The following feature have been added:

- Source synchronous clocks for RX and TX data to simplify timing closure.

The 8-bit data width PXPIPE interface operates at 250 MHz with SSTL\_2 class I signaling. PX1011B does not integrate SSTL\_2 termination resistors inside the IC.

The PCI Express link consists of a differential input pair and a differential output pair. The data rate of these signals is 2.5 Gbit/s.

### 8.1 Receiving data

Incoming data enters the chip at the RX interface. The receiver converts these signals from small amplitude differential signals into rail-to-rail digital signals. The carrier detect circuit detects whether data is present on the line and passes this information through to the SerDes and PCS.

If a valid stream of data is present the Clock and Data Recovery unit (CDR) first recovers the clock from the data and then uses this clock for re-timing the data (i.e., recovering the data).

The de-serializer or Serial-to-Parallel converter (S2P) de-serializes this data into 10-bits parallel data.

Since the S2P has no knowledge about the data, the word alignment is still random. This is fixed in the digital domain by the PCS block. It first detects a 10-bit comma character (K28.5) from the random data stream and aligns the bits. Then it converts the 10-bit raw data into 8-bit words using 8b/10b decoding. An elastic buffer and FIFO brings the resulting data to the right clock domain, which is the RX source synchronous clock domain.

## 8.2 Transmitting data

When the PHY transmits, it receives 8-bit data from the MAC. This data is encoded using an 8b/10b encoding algorithm. The 2 bits overhead of the 8b/10b encoding ensures the serial data will be DC-balanced and has a sufficient 0-to-1 and 1-to-0 transition density for clock recovery at the receiver side.

The serializer or Parallel-to-Serial converter (P2S) serializes the 10 bits data into serial data streams. These data streams are latched into the transmitter, where they are converted into small amplitude differential signals. The transmitter has built-in de-emphasis for a larger eye opening at the receiver side.

The PLL has a sufficiently high bandwidth to handle a 100 MHz reference clock with a 30 kHz to 33 kHz spread spectrum.

## 8.3 Clocking

There are three clock signals used by the PX1011B:

- REFCLK is a 100 MHz external reference clock that the PHY uses to generate the 250 MHz data clock and the internal bit rate clock. This clock may have 30 kHz to 33 kHz spread spectrum modulation.
- TXCLK is a reference clock that the PHY uses to clock the TXDATA and command. This source synchronous clock is provided by the MAC. The PHY expects that the rising edge of TXCLK is centered to the data. The TXCLK has to be synchronous with RXCLK.
- RXCLK is a source synchronous clock provided by the PHY. The RXDATA and status signals are synchronous to this clock. The PHY aligns the rising edge of RXCLK to the center of the data. RXCLK may be used by the MAC to clock its internal logic.

## 8.4 Reset

The PHY must be held in reset until power and REFCLK are stable. It takes the PHY 64  $\mu$ s maximum to stabilize its internal clocks. RXCLK frequency is the same as REFCLK frequency, 100 MHz, during this time. The PHY de-asserts PHYSTATUS when internal clocks are stable.

The PIPE specification recommends that while RESET\_N is asserted, the MAC should have RXDET\_LOOPB de-asserted, TXIDLE asserted, TXCOMP de-asserted, RXPOL de-asserted and power state P1. The MAC can also assert a reset if it receives a physical layer reset packet.

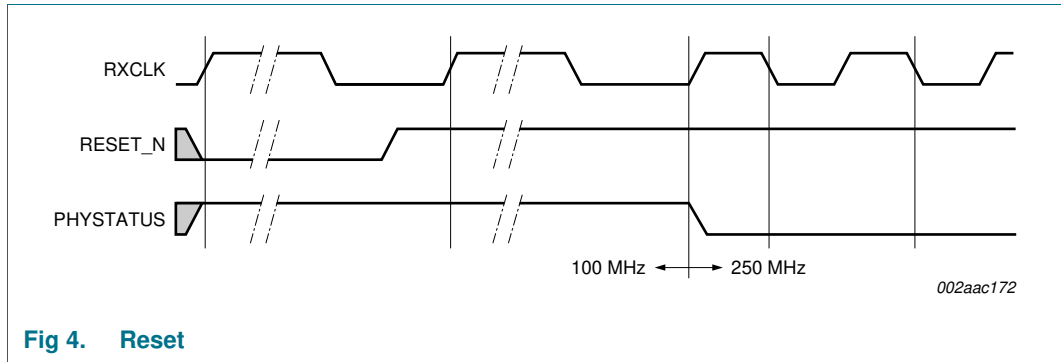

### 8.5 Power management

The power management signals allow the PHY to manage power consumption. The PHY meets all timing constraints provided in the PCI Express base specification regarding clock recovery and link training for the various power states.

Four power states are defined: P0, P0s, P1 and P2. P0 state is the normal operational state for the PHY. When directed from P0 to a lower power state, the PHY can immediately take whatever power saving measures are appropriate.

In states P0, P0s and P1, the PHY keeps internal clocks operational. For all state transitions between these three states, the PHY indicates successful transition into the designated power state by a single cycle assertion of PHYSTATUS. For all power state transitions, the MAC must not begin any operational sequences or further power state transitions until the PHY has indicated that the initial state transition is completed. TXIDLE should be asserted while in power states P0s and P1.

- **P0 state:** All internal clocks in the PHY are operational. P0 is the only state where the PHY transmits and receives PCI Express signaling. P0 is the appropriate PHY power management state for most states in the Link Training and Status State Machine (LTSSM). Exceptions are listed for each lower power PHY state (P0s, P1 and P2).
- **P0s state:** The MAC will move the PHY to this state only when the transmit channel is idle.

While the PHY is in either P0 or P0s power states, if the receiver is detecting an electrical idle, the receiver portion of the PHY can take appropriate power saving measures. Note that the PHY is capable of obtaining bit and symbol lock within the PHY-specified time (N\_FTS with or without common clock) upon resumption of signaling on the receive channel. This requirement only applies if the receiver had previously been bit and symbol locked while in P0 or P0s states.

- **P1 state:** Selected internal clocks in the PHY are turned off. The MAC will move the PHY to this state only when both transmit and receive channels are idle. The PHY indicates a successful entry into P1 (by asserting PHYSTATUS). P1 should be used for the disabled state, all detect states, and L1.idle state of the Link Training and Status State Machine (LTSSM).
- **P2 state:** PHY will enter P1 instead.

**Table 13. Summary of power management state**

| PWRDWN[1:0] | Power management state     | Transmitter         | Receiver | TX PLL | RXCLK | RX PLL/CDR |
|-------------|----------------------------|---------------------|----------|--------|-------|------------|
| 00b         | P0, normal operation       | on <sup>[1]</sup>   | on       | on     | on    | on         |
| 01b         | P0s, power saving state    | idle <sup>[2]</sup> | idle     | on     | on    | on         |
| 10b         | P1, lower power state      | idle <sup>[2]</sup> | idle     | on     | on    | off        |
| 11b         | illegal, PHY will enter P1 | -                   | -        | -      | -     | -          |

[1] TXIDLE = 0

[2] TXIDLE = 1

### 8.6 Receiver detect

When the PHY is in the P1 state, it can be instructed to perform a receiver detection operation to determine if there is a receiver at the other end of the link. Basic operation of receiver detection is that the MAC requests the PHY to do a receiver detect sequence by asserting RXDET\_LOOPB. When the PHY has completed the receiver detect sequence, it drives the RXSTATUS signals to the value of 011b if a receiver is present, and to 000b if there is no receiver. Then the PHY will assert PHYSTATUS to indicate the completion of receiver detect operation. The MAC uses the rising edge of PHYSTATUS to sample the RXSTATUS signals and then de-asserts RXDET\_LOOPB. A few cycles after the RXDET\_LOOPB de-asserts, the PHYSTATUS is also de-asserted.

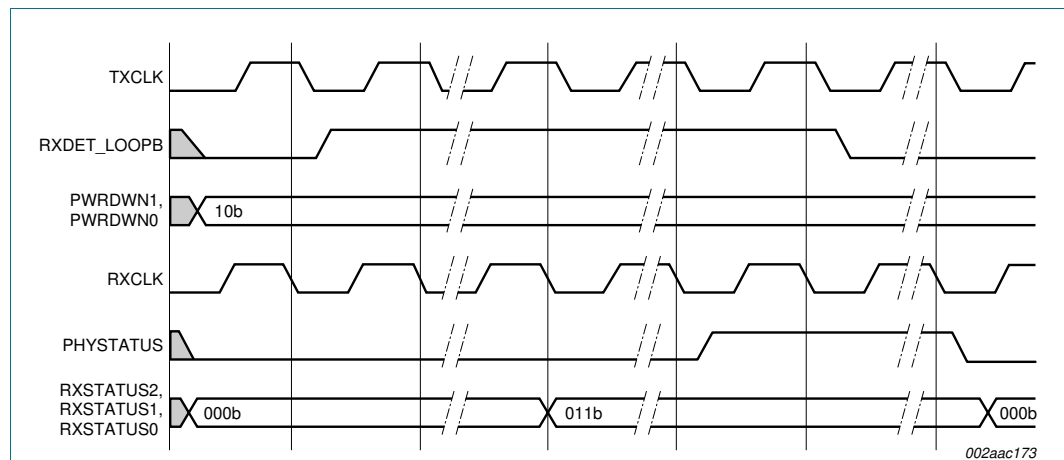

**Fig 5. Receiver detect - receiver present**

### 8.7 Loopback

The PHY supports an internal loopback from the PCI Express receiver to the transmitter with the following characteristics.

The PHY retransmits each 10-bit data and control symbol exactly as received, without applying scrambling or descrambling or disparity corrections, with the following rules:

- If a received 10-bit symbol is determined to be an invalid 10-bit code (i.e., no legal translation to a control or data value possible), the PHY still retransmits the symbol exactly as it was received.
- If a SKP ordered set retransmission requires adding a SKP symbol to accommodate timing tolerance correction, any disparity can be chosen for the SKP symbol.

- The PHY continues to provide the received data on the PXPIPE interface, behaving exactly like normal data reception.
- The PHY transitions from normal transmission of data from the PXPIPE interface to looping back the received data at a symbol boundary.

The PHY begins to loopback data when the MAC asserts RXDET\_LOOPB while doing normal data transmission. The PHY stops transmitting data from the PXPIPE interface, and begins to loopback received symbols. While doing loopback, the PHY continues to present received data on the PXPIPE interface.

The PHY stops looping back received data when the MAC de-asserts RXDET\_LOOPB. Transmission of data on the parallel interface begins immediately.

The timing diagram of [Figure 6](#) shows example timing for beginning loopback. In this example, the receiver is receiving a repeating stream of bytes, Rx-a through Rx-z. Similarly, the MAC is causing the PHY to transmit a repeating stream of bytes Tx-a through Tx-z. When the MAC asserts RXDET\_LOOPB to the PHY, the PHY begins to loopback the received data to the differential TX\_P and TX\_N lines.

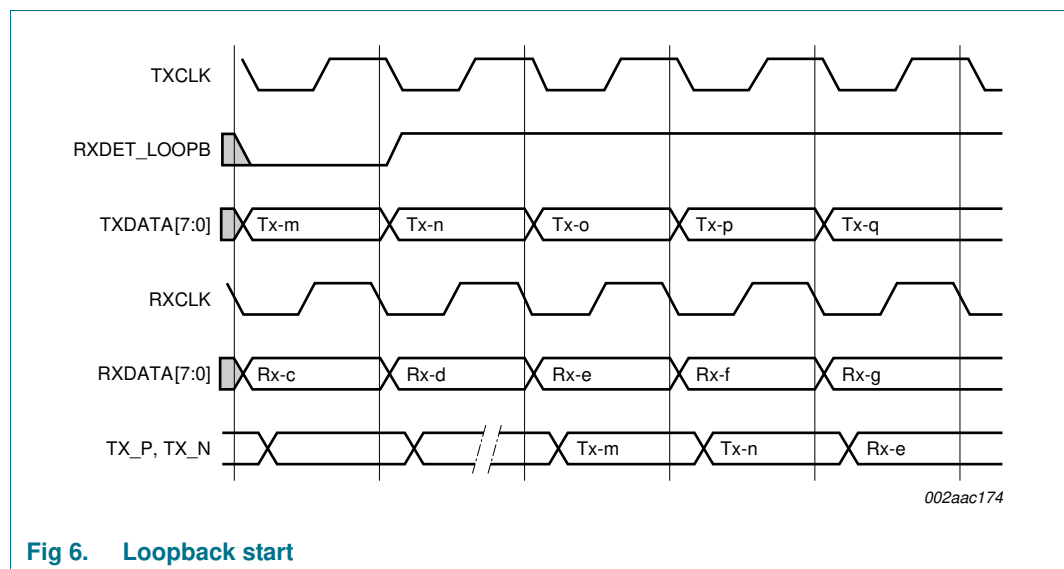

**Fig 6. Loopback start**

The timing diagram of [Figure 7](#) shows an example of switching from loopback mode to normal mode. As soon as the MAC detects an electrical idle ordered-set, the MAC de-asserts RXDET\_LOOPB, asserts TXIDLE and changes the POWERDOWN signals to state P1.

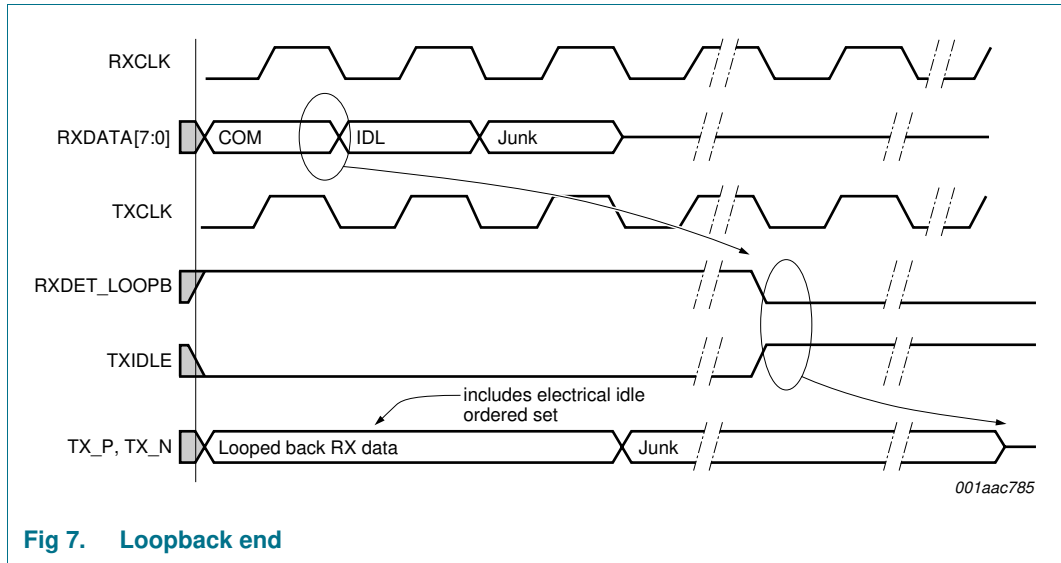

Fig 7. Loopback end

### 8.8 Electrical idle

The PCI Express Base Specification requires that devices send an Electrical Idle ordered-set before TX goes to the electrical idle state.

The timing diagram of [Figure 8](#) shows an example of timing for entering electrical idle.

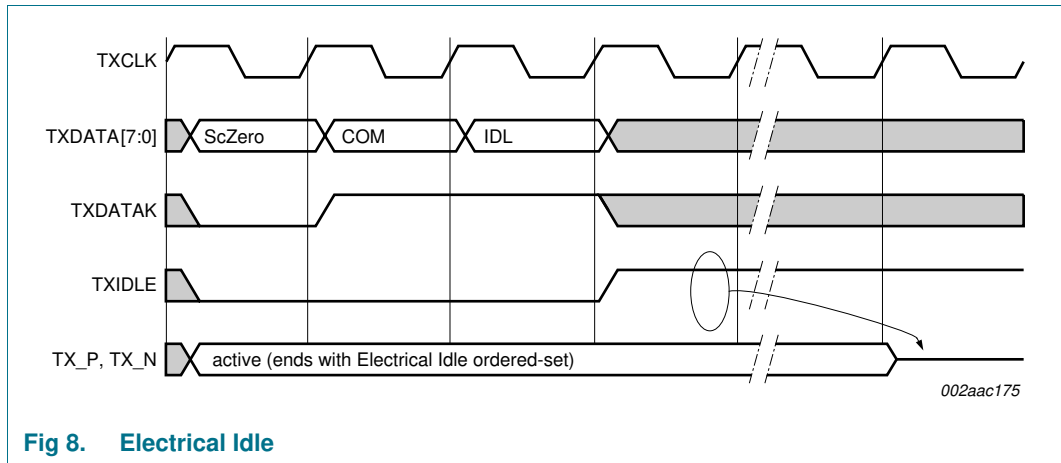

Fig 8. Electrical Idle



Table 14 summarizes the function of some PXPIPE control signals.

**Table 14. Control signals function summary**

| PWRDWN[1:0] | RXDET_LOOPB | TXIDLE | Function description |
|-------------|-------------|--------|----------------------|
| P0: 00b     | 0           | 0      | normal operation     |
|             | 0           | 1      | transmitter in idle  |
|             | 1           | 0      | loopback mode        |
|             | 1           | 1      | illegal              |
| P0s: 01b    | X           | 0      | illegal              |
|             |             | 1      | transmitter in idle  |
| P1: 10b     | X           | 0      | illegal              |
|             | 0           | 1      | transmitter in idle  |
|             | 1           | 1      | receiver detect      |

### 8.9 Clock tolerance compensation

The PHY receiver contains an elastic buffer used to compensate for differences in frequencies between bit rates at the two ends of a link. The elastic buffer is capable of holding at least seven symbols to handle worst case differences (600 ppm) in frequency and worst case intervals between SKP ordered-sets. The PHY is responsible for inserting or removing SKP symbols in the received data stream to avoid elastic buffer overflow or underflow. The PHY monitors the receive data stream, and when a Skip ordered-set is received, the PHY can add or remove one SKP symbol from each SKP ordered-set as appropriate to manage its elastic buffer. Whenever a SKP symbol is added or removed, the PHY will signal this to the MAC using the RXSTATUS signals. These signals have a non-zero value for one clock cycle and indicate whether a SKP symbol was added or removed from the received SKP ordered-set. RXSTATUS should be asserted during the clock cycle when the COM symbol of the SKP ordered-set is moved across the parallel interface. If the removal of a SKP symbol causes no SKP symbols to be transferred across the parallel interface, then RXSTATUS is asserted at the same time that the COM symbol (that was part of the received skip ordered-set) is transmitted across the parallel interface.

Figure 9 shows a sequence where the PHY inserted a SKP symbol in the data stream.

Figure 10 shows a sequence where the PHY removed a SKP symbol from a SKP ordered-set.

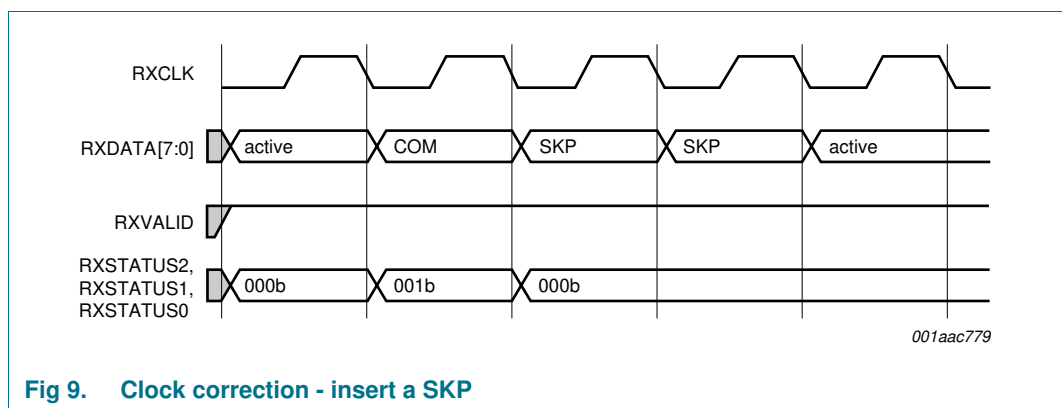

**Fig 9. Clock correction - insert a SKP**

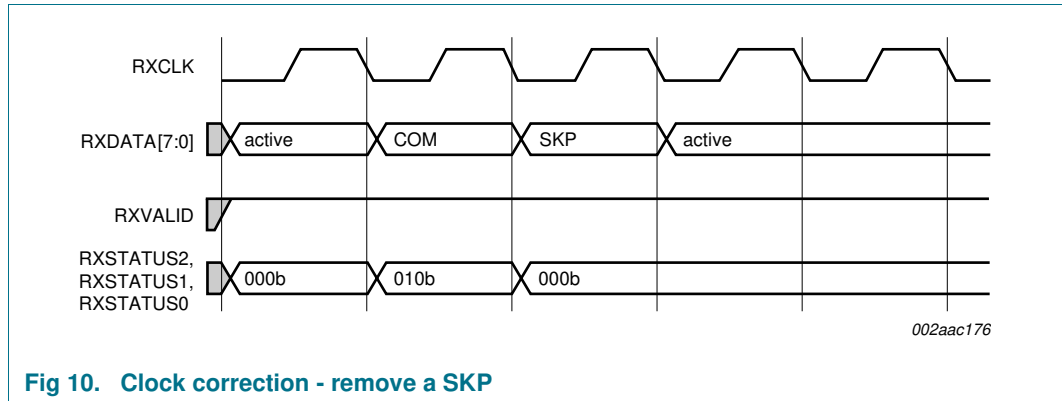

Fig 10. Clock correction - remove a SKP

### 8.10 Error detection

The PHY is responsible for detecting receive errors of several types. These errors are signaled to the MAC layer using the receiver status signals RXSTATUS.

Table 15. Function table PXPIPE status interface signals

| Operating mode           | Output pin |           |           |
|--------------------------|------------|-----------|-----------|
|                          | RXSTATUS2  | RXSTATUS1 | RXSTATUS0 |
| Received data OK         | L          | L         | L         |
| One SKP added            | L          | L         | H         |
| One SKP removed          | L          | H         | L         |
| Receiver detected        | L          | H         | H         |
| 8b/10b decode error      | H          | L         | L         |
| Elastic buffer overflow  | H          | L         | H         |
| Elastic buffer underflow | H          | H         | L         |
| Receive disparity error  | H          | H         | H         |

Because of higher level error detection mechanisms (like CRC) built into the data link layer of PCI Express, there is no need to specifically identify symbols with errors. However, timing information about when the error occurred in the data stream is important. When a receive error occurs, the appropriate error code is asserted for one clock cycle at the point closest to where the error actually occurred.

There are four error conditions that can be encoded on the RXSTATUS signals. If more than one error should happen to occur on a received byte, the errors are signaled with the priority shown below.

1. 8b/10b decode error
2. Elastic buffer overflow
3. Elastic buffer underflow
4. Disparity error

**8.10.1 8b/10b decode errors**

For a detected 8b/10b decode error, the PHY places an EDB (EnD Bad) symbol in the data stream in place of the bad byte, and encodes RXSTATUS with a decode error during the clock cycle when the effected byte is transferred across the parallel interface. In [Figure 11](#) the receiver is receiving a stream of bytes Rx-a through Rx-z, and byte Rx-c has an 8b/10b decode error. In place of that byte, the PHY places an EDB on the parallel interface, and sets RXSTATUS to the 8b/10b decode error code. Note that a byte that cannot be decoded may also have bad disparity, but the 8b/10b error has precedence.

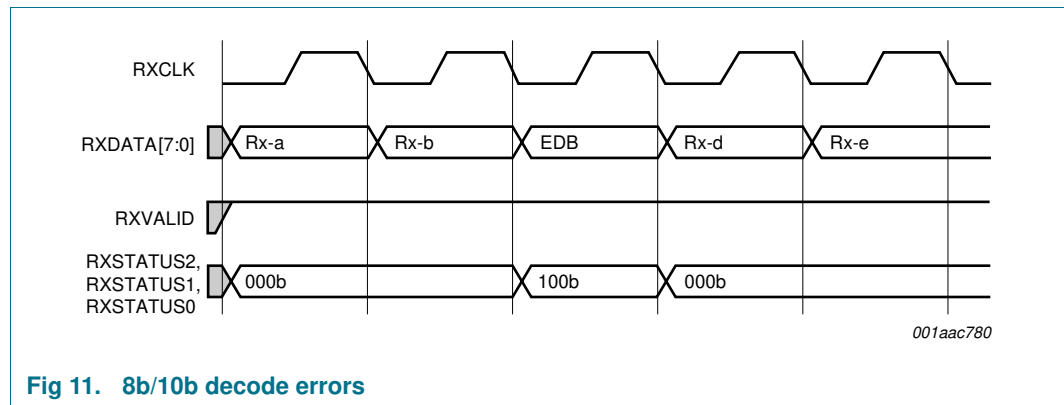

**Fig 11. 8b/10b decode errors**

**8.10.2 Disparity errors**

For a detected disparity error, the PHY asserts RXSTATUS with the disparity error code during the clock cycle when the effected byte is transferred across the parallel interface. In [Figure 12](#) the receiver detected a disparity error on Rx-c data byte, and indicates this with the assertion of RXSTATUS.

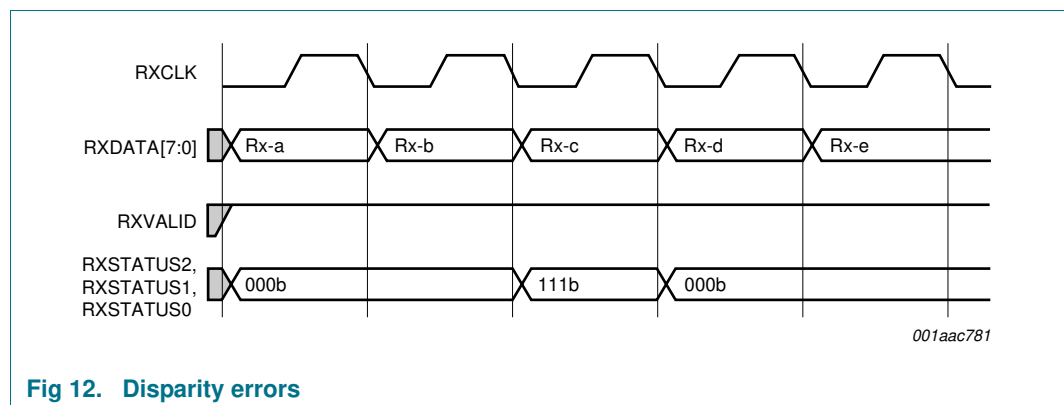

**Fig 12. Disparity errors**

**8.10.3 Elastic buffer**

For elastic buffer errors, an underflow is signaled during the clock cycle when the spurious symbol is moved across the parallel interface. The symbol moved across the interface is the EDB symbol. In the timing diagram [Figure 13](#), the PHY is receiving a repeating set of symbols Rx-a through Rx-z. The elastic buffer underflow causing the EDB symbol to be inserted between the Rx-c and Rx-d symbols. The PHY drives RXSTATUS to indicate buffer underflow during the clock cycle when the EDB is presented on the parallel interface.

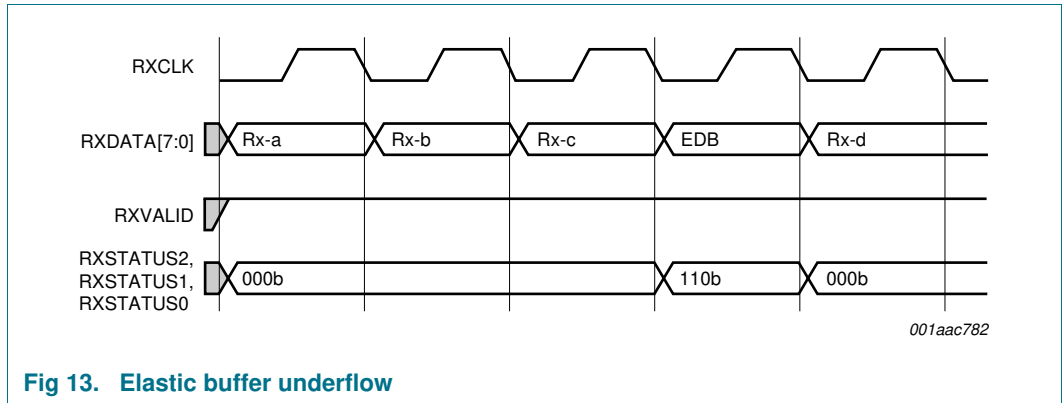

Fig 13. Elastic buffer underflow

For an elastic buffer overflow, the overflow is signaled during the clock cycle where the dropped symbol would have appeared in the data stream. In the timing diagram of [Figure 14](#), the PHY is receiving a repeating set of symbols Rx-a through Rx-z. The elastic buffer overflows causing the symbol Rx-d to be discarded. The PHY drives RXSTATUS to indicate buffer overflow during the clock cycle when Rx-d would have appeared on the parallel interface.

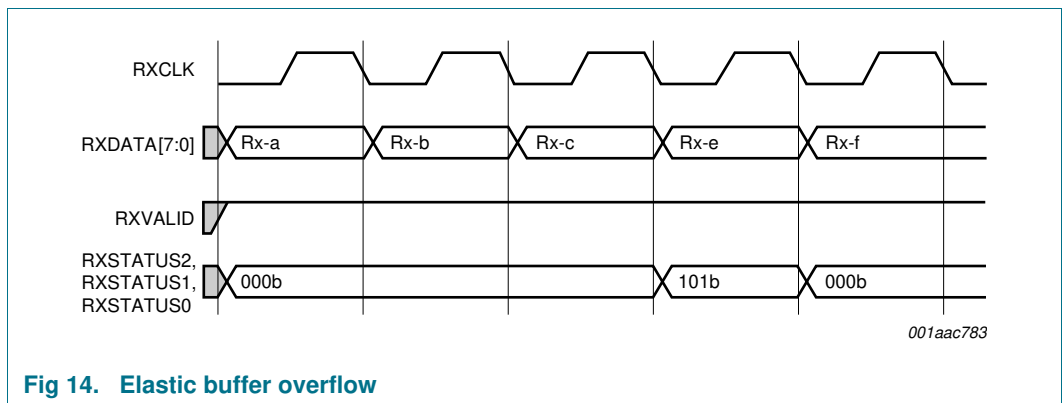

Fig 14. Elastic buffer overflow

### 8.11 Polarity inversion

To support lane polarity inversion, the PHY inverts received data when RXPOL is asserted. The PHY begins data inversion within 20 symbols after RXPOL is asserted.

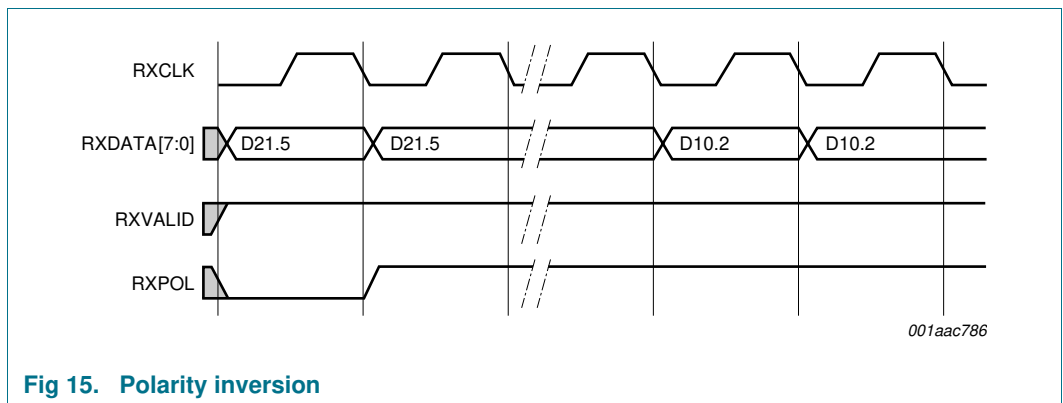

Fig 15. Polarity inversion

### 8.12 Setting negative disparity

To set the running disparity to negative, the MAC asserts TXCOMP for one clock cycle that matches with the data that is to be transmitted with negative disparity.

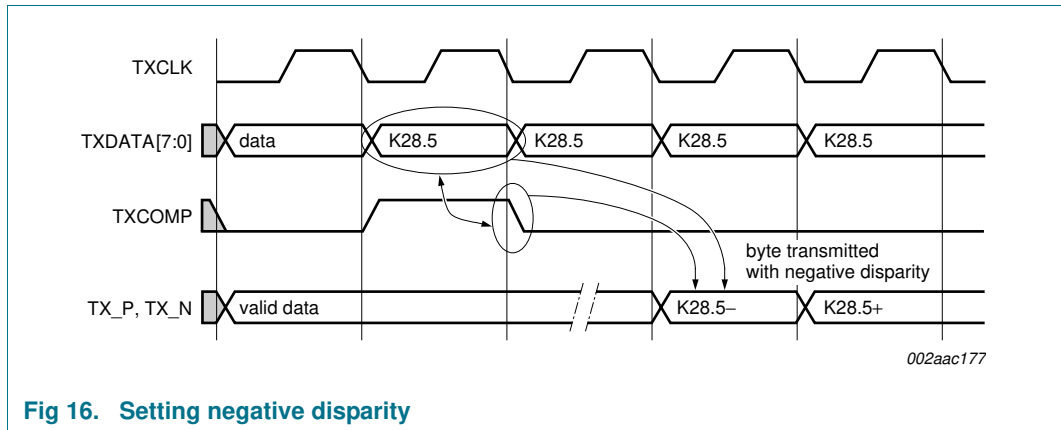

Fig 16. Setting negative disparity

### 8.13 JTAG boundary scan interface

Joint Test Action Group (JTAG) or IEEE 1149.1 is a standard, specifying how to control and monitor the pins of compliant devices on a printed-circuit board. This standard is commonly known as 'JTAG Boundary Scan'.

This standard defines a 5-pin serial protocol for accessing and controlling the signal levels on the pins of a digital circuit, and has some extensions for testing the internal circuitry on the chip itself, which is beyond the scope of this data sheet.

Access to the JTAG interface is provided to the customer for the sole purpose of using boundary scan for interconnect test verification between other compliant devices that may reside on the board. Using JTAG for purposes other than boundary scan may produce undesired effects.

The JTAG interface is a 3.3 V CMOS signaling. JTAG TRST\_N must be asserted LOW for normal device operation. If JTAG is not planned to be used, it is recommended to pull down TRST\_N to V<sub>SS</sub>.

## 9. Limiting values

**Table 16. Limiting values**

*In accordance with the Absolute Maximum Rating System (IEC 60134).*

| Symbol            | Parameter                       | Conditions                        | Min  | Max   | Unit |   |
|-------------------|---------------------------------|-----------------------------------|------|-------|------|---|
| V <sub>DD1</sub>  | digital supply voltage 1        | for JTAG I/O                      | -0.5 | +4.6  | V    |   |
| V <sub>DD2</sub>  | digital supply voltage 2        | for SSTL_2 I/O                    | -0.5 | +3.75 | V    |   |
| V <sub>DD3</sub>  | digital supply voltage 3        | for core                          | -0.5 | +1.7  | V    |   |
| V <sub>DD</sub>   | supply voltage                  | for high-speed serial I/O and PVT | -0.5 | +1.7  | V    |   |
| V <sub>DDA1</sub> | analog supply voltage 1         | for serializer                    | -0.5 | +1.7  | V    |   |
| V <sub>DDA2</sub> | analog supply voltage 2         | for serializer                    | -0.5 | +4.6  | V    |   |
| V <sub>ESD</sub>  | electrostatic discharge voltage | HBM                               | [1]  | -     | 2000 | V |
|                   |                                 | CDM                               | [2]  | -     | 500  | V |
| T <sub>stg</sub>  | storage temperature             |                                   | -55  | +150  | °C   |   |
| T <sub>j</sub>    | junction temperature            |                                   | -55  | +125  | °C   |   |
| T <sub>amb</sub>  | ambient temperature             | operating                         |      |       |      |   |
|                   |                                 | commercial                        | 0    | +70   | °C   |   |
|                   |                                 | industrial                        | -40  | +85   | °C   |   |

[1] Human Body Model: ANSI/EOS/ESD-S5.1-1994, standard for ESD sensitivity testing, Human Body Model - Component level; Electrostatic Discharge Association, Rome, NY, USA.

[2] Charged Device Model: ANSI/EOS/ESD-S5.3.1-1999, standard for ESD sensitivity testing, Charged Device Model - component level; Electrostatic Discharge Association, Rome, NY, USA.

## 10. Thermal characteristics

**Table 17. Thermal characteristics**

| Symbol               | Parameter                                   | Conditions  | Typ    | Unit |
|----------------------|---|-------------|--------|------|
| R <sub>th(j-a)</sub> | thermal resistance from junction to ambient | in free air | [1] 44 | K/W  |
| R <sub>th(j-c)</sub> | thermal resistance from junction to case    | in free air | [1] 10 | K/W  |

[1] Significant variations can be expected due to system variables, such as adjacent devices, or actual air flow across the package.



## 11. Characteristics

Table 18. PCI Express PHY characteristics

| Symbol                        | Parameter                                  | Conditions                        | Min    | Typ | Max    | Unit        |
|-------------------------------|--|-----------------------------------|--------|-----|--------|-------------|
| <b>Supplies</b>               |  |                                   |        |     |        |             |
| V <sub>DDD1</sub>             | digital supply voltage 1                   | for JTAG I/O                      | 3.0    | 3.3 | 3.6    | V           |
| V <sub>DDD2</sub>             | digital supply voltage 2                   | for SSTL_2 I/O                    | 2.3    | 2.5 | 2.7    | V           |
| V <sub>DDD3</sub>             | digital supply voltage 3                   | for core                          | 1.15   | 1.2 | 1.3    | V           |
| V <sub>DD</sub>               | supply voltage                             | for high-speed serial I/O and PVT | 1.15   | 1.2 | 1.3    | V           |
| V <sub>DDA1</sub>             | analog supply voltage 1                    | for serializer                    | 1.15   | 1.2 | 1.3    | V           |
| V <sub>DDA2</sub>             | analog supply voltage 2                    | for serializer                    | 3.0    | 3.3 | 3.6    | V           |
| I <sub>DDD1</sub>             | digital supply current 1                   | for JTAG I/O                      | 0.1    | 1   | 2      | mA          |
| I <sub>DDD2</sub>             | digital supply current 2                   | for SSTL_2; no load               | -      | 24  | 35     | mA          |
| I <sub>DDD3</sub>             | digital supply current 3                   | for core                          | 5      | 10  | 15     | mA          |
| I <sub>DD</sub>               | supply current                             | for high-speed serial I/O and PVT | 15     | 20  | 30     | mA          |
| I <sub>DDA1</sub>             | analog supply current 1                    | for serializer                    | 15     | 20  | 31     | mA          |
| I <sub>DDA2</sub>             | analog supply current 2                    | for serializer                    | 7      | 10  | 15     | mA          |
| <b>Receiver</b>               |  |                                   |        |     |        |             |
| UI                            | unit interval                              |                                   | 399.88 | 400 | 400.12 | ps          |
| V <sub>RX_DIFFp-p</sub>       | differential input peak-to-peak voltage    |                                   | 0.205  | -   | 1.2    | V           |
| t <sub>RX_MAX_JITTER</sub>    | maximum receiver jitter time               |                                   | -      | -   | 0.6    | UI          |
| V <sub>IDLE_DET_DIFFp-p</sub> | electrical idle detect threshold           |                                   | 65     | -   | 205    | mV          |
| Z <sub>RX_DC</sub>            | DC input impedance                         |                                   | 40     | 50  | 60     | Ω           |
| Z <sub>RX_HIGH_IMP_DC</sub>   | powered-down DC input impedance            |                                   | 200    | -   | -      | kΩ          |
| RL <sub>RX_DIFF</sub>         | differential return loss                   |                                   | 15     | -   | -      | dB          |
| RL <sub>RX_CM</sub>           | common mode return loss                    |                                   | 6      | -   | -      | dB          |
| t <sub>lock(CDR)(ref)</sub>   | CDR lock time (reference loop)             |                                   | -      | -   | 50     | μs          |
| t <sub>lock(CDR)(data)</sub>  | CDR lock time (data loop)                  |                                   | -      | -   | 2.5    | μs          |
| t <sub>RX_latency</sub>       | receiver latency                           | 1 clock cycle is 4 ns             | 6      | -   | 13     | clock cycle |
| <b>Reference clock</b>        |  |                                   |        |     |        |             |
| f <sub>clk(ref)</sub>         | reference clock frequency                  |                                   | 99.97  | 100 | 100.03 | MHz         |
| Δf <sub>mod(clk)(ref)</sub>   | reference clock modulation frequency range |                                   | -0.5   | -   | +0     | %           |
| f <sub>mod(clk)(ref)</sub>    | reference clock modulation frequency       |                                   | 30     | -   | 33     | kHz         |
| V <sub>IH(se)REFCLK</sub>     | REFCLK single-end HIGH-level input voltage |                                   | -      | 0.7 | 1.15   | V           |
| V <sub>IL(se)REFCLK</sub>     | REFCLK single-end LOW-level input voltage  |                                   | -0.3   | 0   | -      | V           |
| Z <sub>C-DC</sub>             | clock source DC impedance                  |                                   | 40     | 50  | 60     | Ω           |

Table 18. PCI Express PHY characteristics ...continued

| Symbol                        | Parameter  | Conditions  | Min    | Typ | Max    | Unit           |
|-------------------------------|--|---|--------|-----|--------|----------------|
| dV/dt                         | rate of change of voltage  | at rising edge;<br>measured from –150 mV<br>to +150 mV on the<br>differential waveform;<br><a href="#">Figure 17</a>  | 0.6    | -   | 4.0    | V/ns           |
|                               |  | at falling edge;<br>measured from +150 mV<br>to –150 mV on the<br>differential waveform;<br><a href="#">Figure 17</a> | 0.6    | -   | 4.0    | V/ns           |
| V <sub>IH</sub>               | differential input HIGH voltage  |   | +150   | -   | -      | mV             |
| V <sub>IL</sub>               | differential input LOW voltage   |   | -      | -   | -150   | mV             |
| δ <sub>REFCLK</sub>           | duty cycle on pin REFCLK   | on pin REFCLK_N and<br>pin REFCLK_P   | 40     | -   | 60     | %              |
| <b>Transmitter</b>            |  |   |        |     |        |                |
| UI                            | unit interval  |   | 399.88 | 400 | 400.12 | ps             |
| V <sub>TX_DIFFp-p</sub>       | differential peak-to-peak output<br>voltage  |   | 0.8    | -   | 1.2    | V              |
| t <sub>TX_EYE_m-mJITTER</sub> | maximum time between the jitter<br>median and maximum deviation from<br>the median |   | -      | 35  | 50     | ps             |
| t <sub>TX_JITTER_MAX</sub>    | maximum transmitter jitter time  |   | -      | 60  | 100    | ps             |
| V <sub>TX_DE_RATIO</sub>      | de-emphasized differential output<br>voltage ratio                                 |   | -3.0   | -   | -4.0   | dB             |
| t <sub>TX_RISE</sub>          | D+/D- TX output rise time  |   | 50     | 75  | -      | ps             |
| t <sub>TX_FALL</sub>          | D+/D- TX output fall time  |   | 50     | 75  | -      | ps             |
| V <sub>TX_CM_ACp</sub>        | RMS AC peak common mode output<br>voltage  |   | -      | -   | 20     | mV             |
| ΔV <sub>CM_DC_ACT_IDLE</sub>  | absolute delta of DC common mode<br>voltage during L0 and electrical idle          |   | 0      | -   | 100    | mV             |
| ΔV <sub>CM_DC_LINE</sub>      | absolute delta of DC common mode<br>voltage between D+ and D-                      |   | 0      | -   | 25     | mV             |
| V <sub>TX_CM_DC</sub>         | TX DC common mode voltage  |   | 0      | -   | 3.6    | V              |
| I <sub>TX_SHORT</sub>         | TX short-circuit current limit   |   | -      | 20  | 90     | mA             |
| RL <sub>TX_DIFF</sub>         | differential return loss   |   | 12     | -   | -      | dB             |
| RL <sub>TX_CM</sub>           | common mode return loss  |   | 6      | -   | -      | dB             |
| Z <sub>TX_DC</sub>            | transmitter DC impedance   |   | 40     | 50  | 60     | Ω              |
| C <sub>TX</sub>               | AC coupling capacitor  |   | 75     | 100 | 200    | nF             |
| t <sub>lock(PLL)</sub>        | PLL lock time  |   | -      | -   | 50     | μs             |
| t <sub>TX_latency</sub>       | transmitter latency  | 1 clock cycle is 4 ns   | 4      | -   | 9      | clock<br>cycle |
| t <sub>P0s_exit_latency</sub> | P0s state exit latency   |   | -      | -   | 2.5    | μs             |
| t <sub>P1_exit_latency</sub>  | P1 state exit latency  |   | -      | -   | 64     | μs             |
| t <sub>RESET-PHYSTATUS</sub>  | RESET_N HIGH to PHYSTATUS LOW<br>time  |   | -      | -   | 64     | μs             |

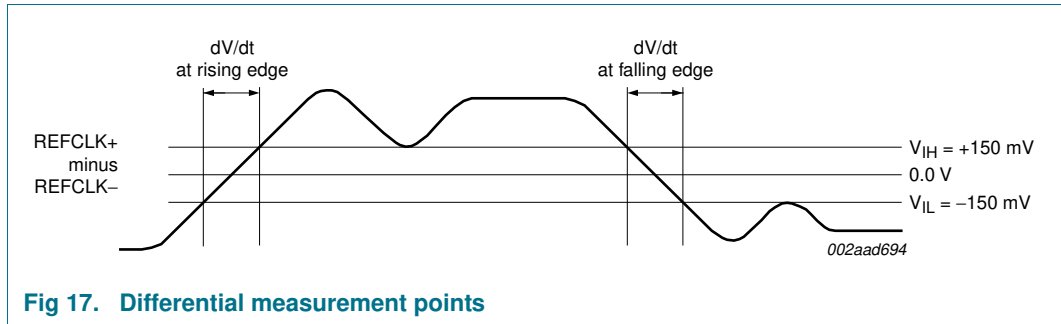

Fig 17. Differential measurement points

Table 19. PXPIPE characteristics

| Symbol  | Parameter                           | Conditions    | Min              | Typ  | Max              | Unit |
|---|-------------------------------------|---------------|------------------|------|------------------|------|
| $f_{RXCLK}$   | RXCLK frequency                     |               | 249.925          | 250  | 250.075          | MHz  |
| $f_{TXCLK}$   | TXCLK frequency                     |               | 249.925          | 250  | 250.075          | MHz  |
| $V_{VREFS}$   | voltage on pin VREFS                |               | [1] 1.13         | 1.25 | 1.38             | V    |
| $V_{OH(SSTL2)}$                                       | SSTL_2 HIGH-level output voltage    | AC            | $V_{TT} + 0.61$  | -    | -                | V    |
| $V_{OL(SSTL2)}$                                       | SSTL_2 LOW-level output voltage     | AC            | -                | -    | $V_{TT} - 0.61$  | V    |
| $V_{IH(SSTL2)}$                                       | SSTL_2 HIGH-level input voltage     | AC            | $V_{ref} + 0.31$ | -    | -                | V    |
| $V_{IL(SSTL2)}$                                       | SSTL_2 LOW-level input voltage      | AC            | -                | -    | $V_{ref} - 0.31$ | V    |
| <b>Input signals; measured with respect to TXCLK</b>  |                                     |               |                  |      |                  |      |
| $t_{su(TX)(PXPIPE)}$                                  | set-up time of PXPIPE input signal  | see Figure 18 | 500              | -    | -                | ps   |
| $t_{h(TX)(PXPIPE)}$                                   | hold time of PXPIPE input signal    | see Figure 18 | 500              | -    | -                | ps   |
| <b>Output signals; measured with respect to RXCLK</b> |                                     |               |                  |      |                  |      |
| $t_{su(RX)(PXPIPE)}$                                  | set-up time of PXPIPE output signal | see Figure 18 | 1500             | -    | -                | ps   |
| $t_{h(RX)(PXPIPE)}$                                   | hold time of PXPIPE output signal   | see Figure 18 | 1500             | -    | -                | ps   |

[1] Reference voltage for SSTL\_2 class I I/O.

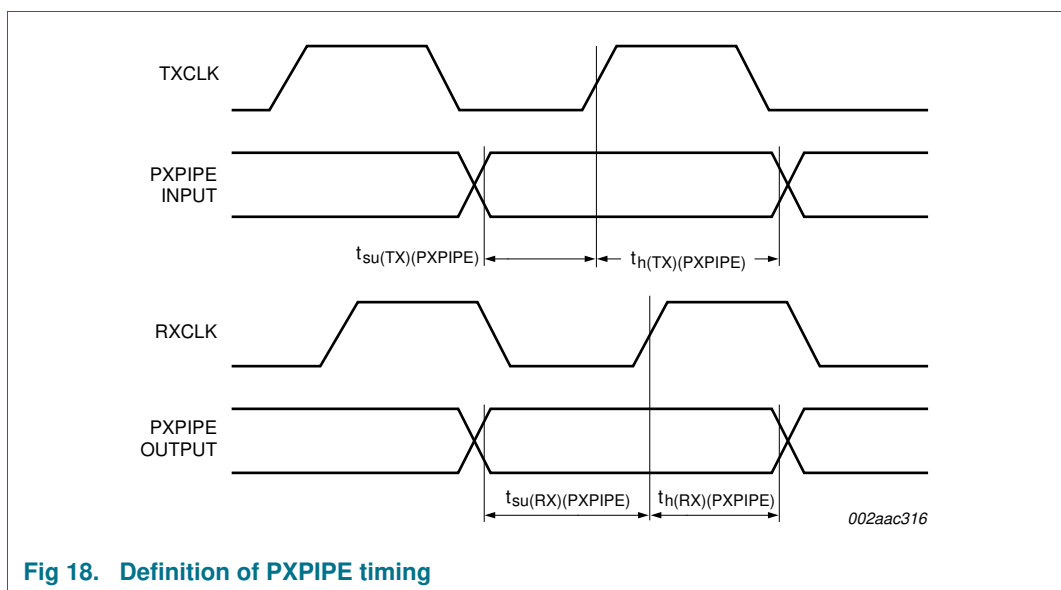
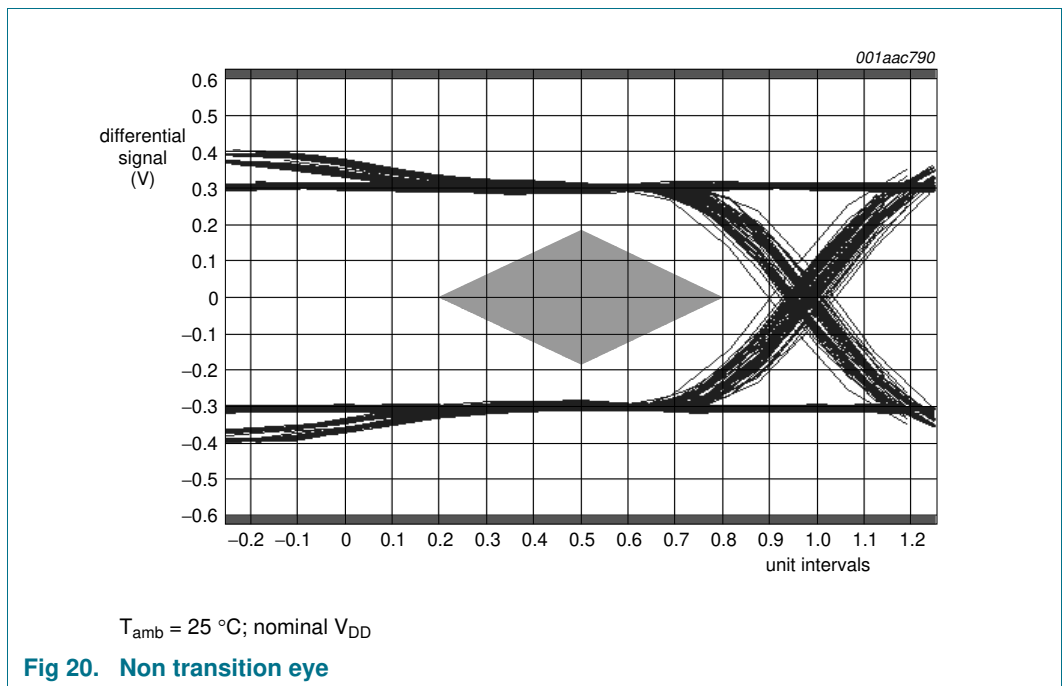
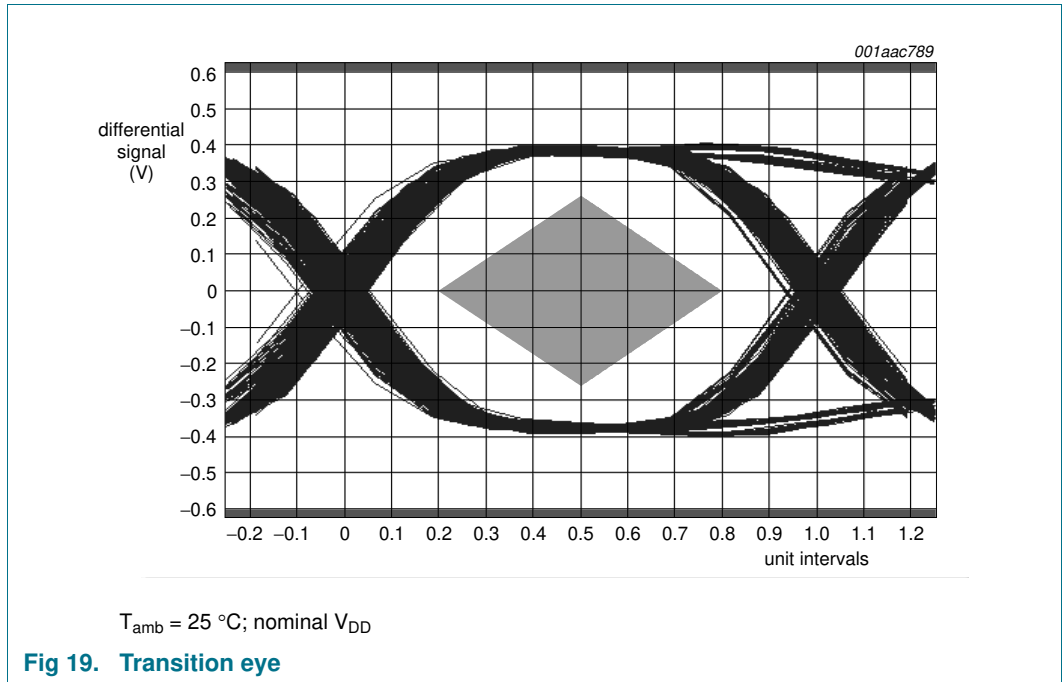

Fig 18. Definition of PXPIPE timing



## 12. Package outline

LFBGA81: plastic low profile fine-pitch ball grid array package; 81 balls; body 9 x 9 x 1.05 mm

SOT643-1

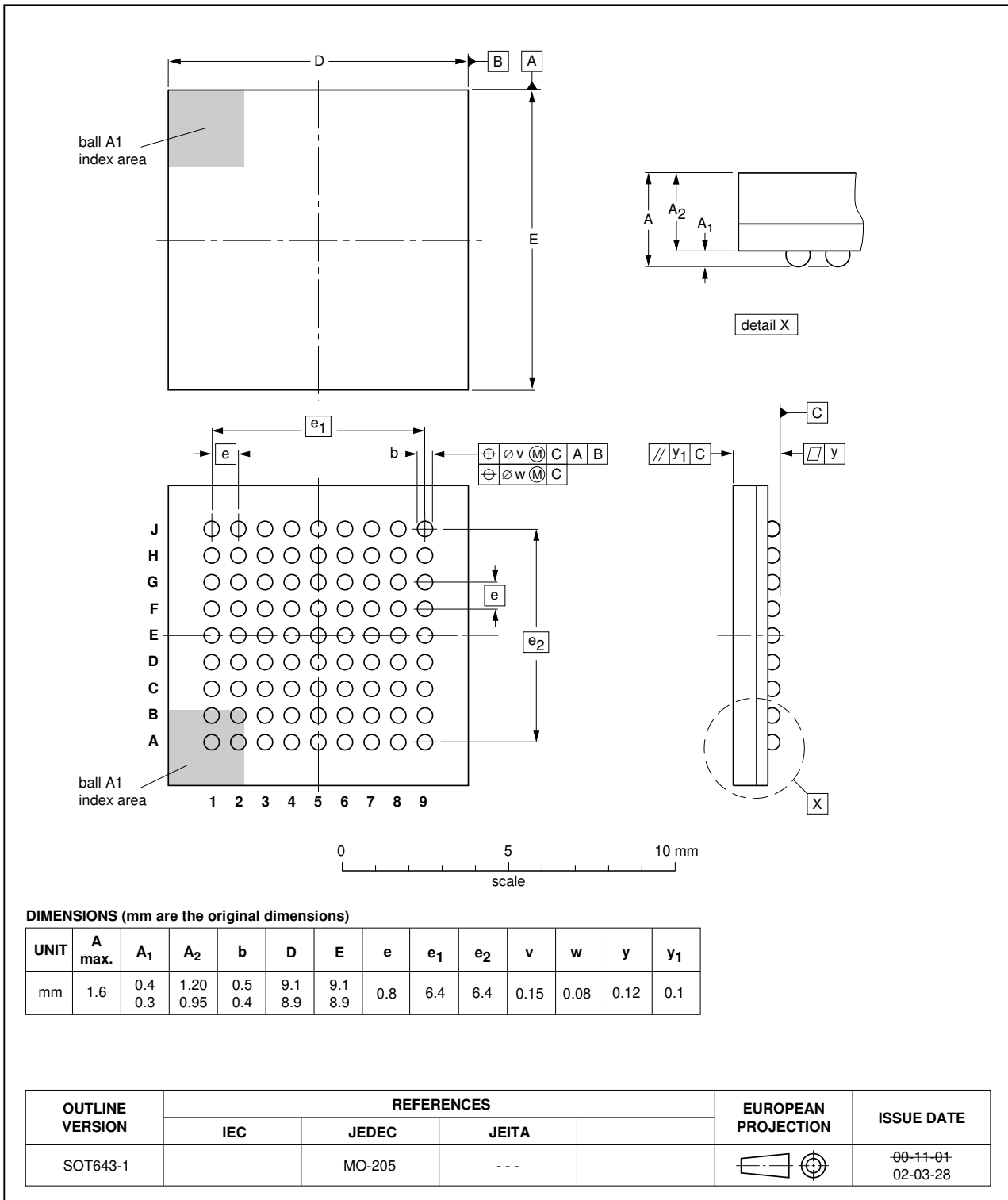

Fig 21. Package outline SOT643-1 (LFBGA81)

## 13. Soldering of SMD packages

This text provides a very brief insight into a complex technology. A more in-depth account of soldering ICs can be found in Application Note *AN10365 "Surface mount reflow soldering description"*.

### 13.1 Introduction to soldering

Soldering is one of the most common methods through which packages are attached to Printed Circuit Boards (PCBs), to form electrical circuits. The soldered joint provides both the mechanical and the electrical connection. There is no single soldering method that is ideal for all IC packages. Wave soldering is often preferred when through-hole and Surface Mount Devices (SMDs) are mixed on one printed wiring board; however, it is not suitable for fine pitch SMDs. Reflow soldering is ideal for the small pitches and high densities that come with increased miniaturization.

### 13.2 Wave and reflow soldering

Wave soldering is a joining technology in which the joints are made by solder coming from a standing wave of liquid solder. The wave soldering process is suitable for the following:

- Through-hole components
- Leaded or leadless SMDs, which are glued to the surface of the printed circuit board

Not all SMDs can be wave soldered. Packages with solder balls, and some leadless packages which have solder lands underneath the body, cannot be wave soldered. Also, leaded SMDs with leads having a pitch smaller than ~0.6 mm cannot be wave soldered, due to an increased probability of bridging.

The reflow soldering process involves applying solder paste to a board, followed by component placement and exposure to a temperature profile. Leaded packages, packages with solder balls, and leadless packages are all reflow solderable.

Key characteristics in both wave and reflow soldering are:

- Board specifications, including the board finish, solder masks and vias
- Package footprints, including solder thieves and orientation
- The moisture sensitivity level of the packages
- Package placement
- Inspection and repair
- Lead-free soldering versus SnPb soldering

### 13.3 Wave soldering

Key characteristics in wave soldering are:

- Process issues, such as application of adhesive and flux, clinching of leads, board transport, the solder wave parameters, and the time during which components are exposed to the wave
- Solder bath specifications, including temperature and impurities