



Chipsmall Limited consists of a professional team with an average of over 10 year of expertise in the distribution of electronic components. Based in Hongkong, we have already established firm and mutual-benefit business relationships with customers from,Europe,America and south Asia,supplying obsolete and hard-to-find components to meet their specific needs.

With the principle of “Quality Parts,Customers Priority,Honest Operation,and Considerate Service”,our business mainly focus on the distribution of electronic components. Line cards we deal with include Microchip,ALPS,ROHM,Xilinx,Pulse,ON,Everlight and Freescale. Main products comprise IC,Modules,Potentiometer,IC Socket,Relay,Connector.Our parts cover such applications as commercial,industrial, and automotives areas.

We are looking forward to setting up business relationship with you and hope to provide you with the best service and solution. Let us make a better world for our industry!



## Contact us

Tel: +86-755-8981 8866 Fax: +86-755-8427 6832

Email & Skype: info@chipsmall.com Web: www.chipsmall.com

Address: A1208, Overseas Decoration Building, #122 Zhenhua RD., Futian, Shenzhen, China



**QT-Brightek PLCC4 Series**

**PLCC4 RGB LED**

**Part No.: QBLP677-RGB2 (High Bright)**

Product: QBLP677-RGB2 (High Bright)	Date: June 28, 2016	Page 1 of 10
	Version# 2.1	

---

**Table of Contents:**

Introduction .....	3
Electrical / Optical Characteristic: (T=25 °C) .....	4
Absolute Maximum Rating .....	4
Characteristic Curves.....	6
Solder Profile & Footprint.....	7
Packing & Labeling .....	8
Labeling .....	9
Ordering Information .....	9
Revision History .....	10
Disclaimer .....	10

## Introduction

**Feature:**

- Black Face
- High Bright
- White diffused lens
- Ultra bright PLCC4 RGB LED
- Common Anode
- Triangle die placement
- InGaN technology for IB/IG
- AlInGaP technology for R
- 120 degree viewing angle

**Description:**

This PLCC4 RGB LEDs have a height profile of 1.85mm. Combination of high brightness output and robust package, this LED is ideal for architecture lighting, status indication, and color mixing applications.

**Application:**

- Status indication
- Back lighting application
- Full Color LED panel

**Certification & Compliance:**

- TS16949
- ISO9001
- RoHS Compliant



**Dimension:**

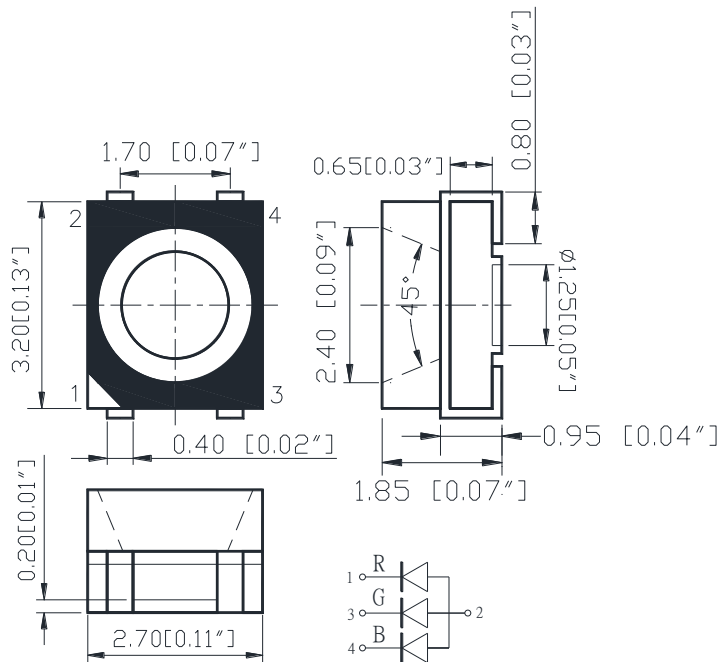

Units: mm / tolerance = +/-0.2mm

### Electrical / Optical Characteristic: (T=25 °C)

Product	Color	I <sub>F</sub> (mA)	V <sub>F</sub> (V)		λ <sub>D</sub> (nm)			I <sub>V</sub> (mcd)	
			Typ.	Max.	Min.	Typ.	Max.	Min.	Typ.
QBLP677-RGB2 (High Bright)	Red	20	2.0	2.5	615	624	630	510	700
	True Green	20	3.1	3.7	519	525	534	1080	1450
	Blue	20	3.1	3.7	461	470	476	200	280

### Absolute Maximum Rating

Material	P <sub>d</sub> (mW)	I <sub>F</sub> (mA)	I <sub>FP</sub> (mA)*	V <sub>R</sub> (V)	T <sub>OP</sub> (°C)	T <sub>ST</sub> (°C)	T <sub>SOL</sub> (°C)**
AllnGaP (R)	75	30	125	5	-40 ~ +80	-40 ~ +85	260
InGaN (IB/IG)	111	30	125	5	-40 ~ +80	-40 ~ +85	260

\*Duty 1/8 @ 1kHz

\*\*IR Reflow for no more than 10 sec @ 260 °C

### Luminous Intensity I<sub>V</sub> for Red @ I<sub>F</sub>=20mA

Bin	Min.	Max.	Unit
12	510	645	mcd
13	645	800	
14	800	1000	

### Luminous Intensity I<sub>V</sub> for True Green @ I<sub>F</sub>=20mA

Bin	Min.	Max.	Unit
12	1080	1350	mcd
13	1350	1700	
14	1700	2125	

### Luminous Intensity I<sub>V</sub> for Blue @ I<sub>F</sub>=20mA

Bin	Min.	Max.	Unit
10	200	250	mcd
11	250	315	
12	315	395	

**Dominant Wavelength  $\lambda_D$  for Red @  $I_F=20mA$** 

Bin	Min.	Max.	Unit
2	615	620	nm
3	620	625	
4	625	630	

**Dominant Wavelength  $\lambda_D$  for True Green @  $I_F=20mA$** 

Bin	Min.	Max.	Unit
2	519	524	nm
3	524	529	
4	529	534	

**Dominant Wavelength  $\lambda_D$  for Blue @  $I_F=20mA$** 

Bin	Min.	Max.	Unit
2	461	466	nm
3	466	471	
4	471	476	

**Characteristic Curves**

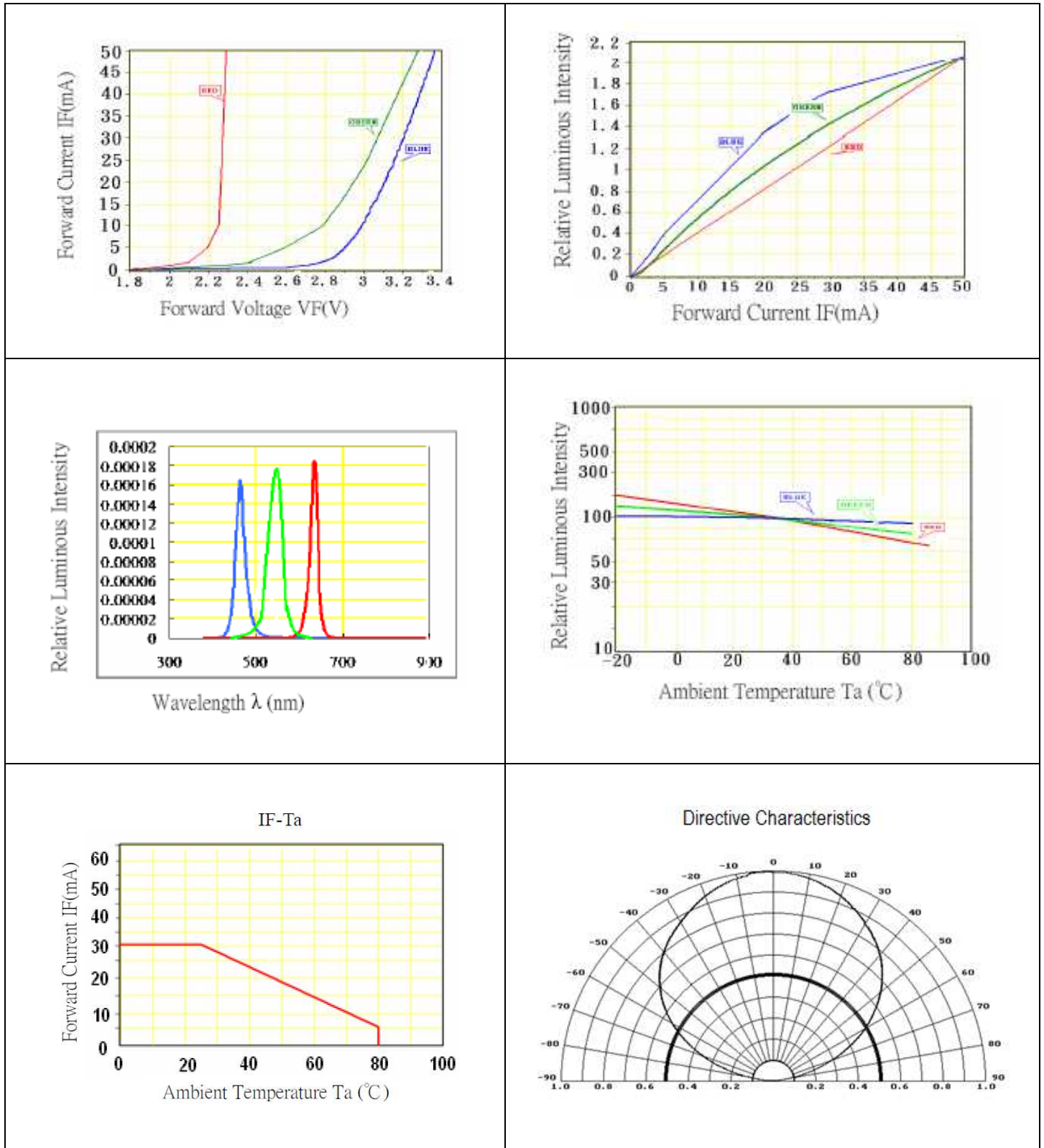

## Solder Profile & Footprint

- Recommended tin solder specifications: melting temperature in the range of 178~192 °C
- The recommended reflow soldering profile is as follows (temperatures indicated are as measured on the surface of the LED resin):

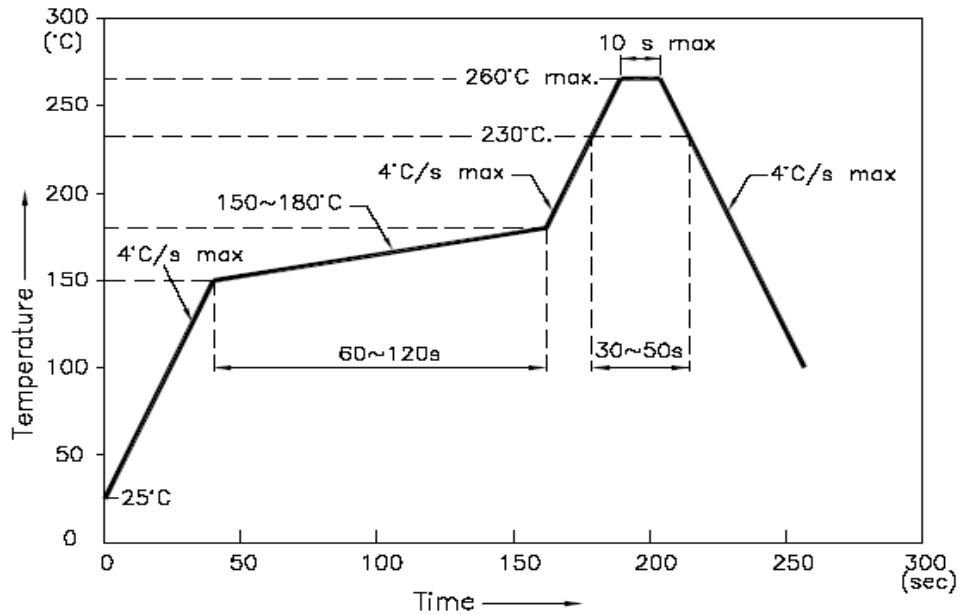

### Recommended Pad Layout

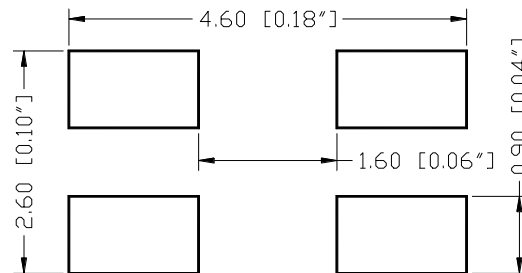

Units: mm

Tolerance: ± 0.2mm



## Packing & Labeling

Reel Dimension:

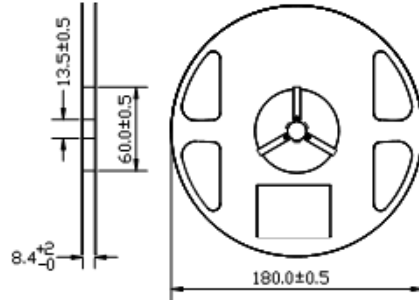

Unit: mm

Tape Dimension:

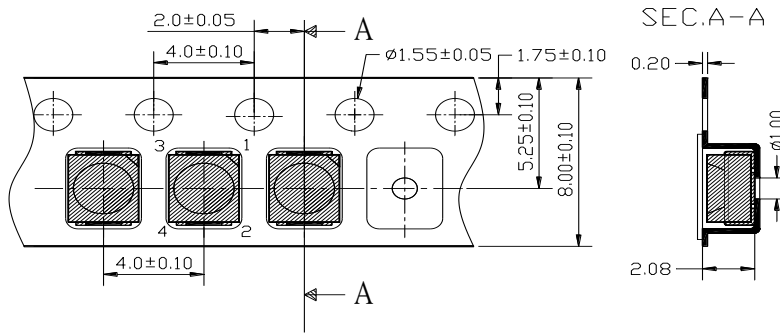

Unit: mm

Arrangement of Tape:

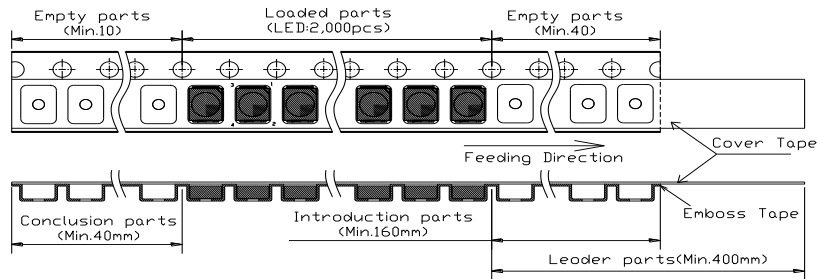

Packaging Specifications:

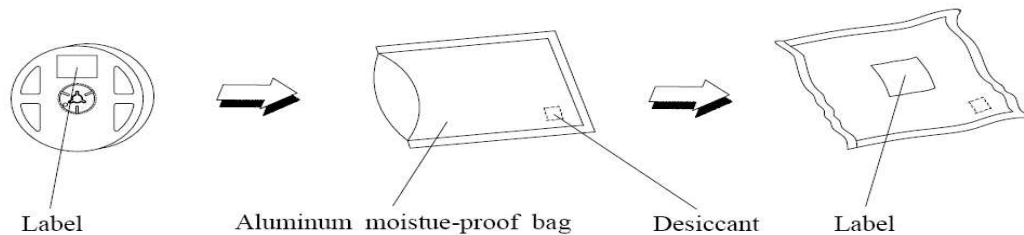

**Labeling**

Part No: \_\_\_\_\_

Customer P/N: \_\_\_\_\_

Item: \_\_\_\_\_

Q'ty: \_\_\_\_\_

Vf: \_\_\_\_\_

Iv: \_\_\_\_\_

WI: \_\_\_\_\_

Date: \_\_\_\_\_

**Made in China****Ordering Information**

Part #	Orderable Part #	Spec Range	Quantity per reel
QBLP677-RGB2 (High Bright)	QBLP677-RGB2 (High Bright)	Per bin selection on page 4 and 5.	1,000 units

## Revision History

Description:	Revision #	Revision Date
New Release of QBLP677-RGB2	V1.0	02/28/2011
Update Brightness	V1.1	10/13/2011
Bin code added/ Indicate the High bright version	V1.2	12/28/2011
Amend the bin code	V1.3	12/29/2011
Amend the brightness/ Wavelength	V1.4	04/03/2012
Update drawing and packing spec	V2.0	10/12/2013
Update dimension	V2.1	06/28/2016

## Disclaimer

QT-BRIGHTTEK reserves the right to make changes without further notice to any products herein to improve reliability, function or design. QT-BRIGHTTEK does not assume any liability arising out of the application or use of any product or circuit described herein; neither does it convey any license under its patent rights, nor the rights of others.

## Life Support Policy

QT-BRIGHTTEK's products are not authorized for use as critical components in life support devices or systems without the express written approval of QT-BRIGHTTEK. As used herein:

1. Life support devices or systems are devices or systems which, (a) are intended for surgical implant into the body, or (b) support or sustain life, and (c) whose failure to perform when properly used in accordance with instructions for use provided in the labeling, can be reasonably expected to result in a significant injury of the user.
2. A critical component in any component of a life support device or system whose failure to perform can be reasonably expected to cause the failure of the life support device or system, or to affect its safety or effectiveness.