



Chipsmall Limited consists of a professional team with an average of over 10 year of expertise in the distribution of electronic components. Based in Hongkong, we have already established firm and mutual-benefit business relationships with customers from,Europe,America and south Asia,supplying obsolete and hard-to-find components to meet their specific needs.

With the principle of “Quality Parts,Customers Priority,Honest Operation,and Considerate Service”,our business mainly focus on the distribution of electronic components. Line cards we deal with include Microchip,ALPS,ROHM,Xilinx,Pulse,ON,Everlight and Freescale. Main products comprise IC,Modules,Potentiometer,IC Socket,Relay,Connector.Our parts cover such applications as commercial,industrial, and automotives areas.

We are looking forward to setting up business relationship with you and hope to provide you with the best service and solution. Let us make a better world for our industry!



Contact us

Tel: +86-755-8981 8866 Fax: +86-755-8427 6832

Email & Skype: info@chipsmall.com Web: www.chipsmall.com

Address: A1208, Overseas Decoration Building, #122 Zhenhua RD., Futian, Shenzhen, China





■ Features :

- Universal AC input / Full range
- Built-in active PFC function, PF>0.95
- Protections: Short circuit / Over load / Over voltage
- Forced air cooling by built-in DC fan
- CH4:±Polarity is selectable
- Fixed switching frequency at 100KHz
- 3 years warranty



SPECIFICATION

MODEL		QP-150-3A				QP-150-3B				QP-150-3C				
OUTPUT	OUTPUT NUMBER	CH1	CH2	CH3	CH4	CH1	CH2	CH3	CH4	CH1	CH2	CH3	CH4	
	DC VOLTAGE	5V	3.3V	12V	-5V	5V	3.3V	12V	-12V	5V	3.3V	15V	-15V	
	RATED CURRENT	10A	10A	5A	0.6A	10A	10A	5A	0.6A	10A	10A	4A	0.6A	
	CURRENT RANGE	3 ~ 15A	0 ~ 15A	0.4 ~ 5A	0 ~ 1A	3 ~ 15A	0 ~ 15A	0.4 ~ 5A	0 ~ 1A	3 ~ 15A	0 ~ 15A	0.4 ~ 5A	0 ~ 1A	
	RATED POWER (max.)	146W				150.2W				152W				
	RIPPLE & NOISE (max.) Note.2	100mVp-p	100mVp-p	150mVp-p	150mVp-p	100mVp-p	100mVp-p	150mVp-p	150mVp-p	100mVp-p	100mVp-p	150mVp-p	150mVp-p	
	VOLTAGE ADJ. RANGE	CH1: 4.75 ~ 5.5V		CH2: 3.14 ~ 3.63V		CH1: 4.75 ~ 5.5V		CH2: 3.14 ~ 3.63V		CH1: 4.75 ~ 5.5V		CH2: 3.14 ~ 3.63V		
	VOLTAGE TOLERANCE Note.3	± 3.0%	± 3.0%	± 6.0%	± 5.0%	± 3.0%	± 3.0%	± 6.0%	± 5.0%	± 3.0%	± 3.0%	+8,-6%	± 5.0%	
	LINE REGULATION	± 1.0%	± 1.0%	± 2.0%	± 1.0%	± 1.0%	± 1.0%	± 2.0%	± 1.0%	± 1.0%	± 1.0%	± 2.0%	± 1.0%	
	LOAD REGULATION	± 2.0%	± 2.0%	± 6.0%	± 2.0%	± 2.0%	± 2.0%	± 6.0%	± 2.0%	± 2.0%	± 2.0%	± 6.0%	± 2.0%	
SETUP, RISE TIME	800ms, 50ms/230VAC				1800ms, 50ms/115VAC at full load									
HOLD UP TIME (Typ.)	24ms/230VAC		24ms/115VAC at full load											
INPUT	VOLTAGE RANGE	90 ~ 264VAC		127 ~ 370VDC										
	FREQUENCY RANGE	47 ~ 63Hz												
	POWER FACTOR (Typ.)	PF>0.95/230VAC				PF>0.98/115VAC at full load								
	EFFICIENCY (Typ.)	73%					75%				74%			
	AC CURRENT (Typ.)	2.5A/115VAC		1.2A/230VAC										
	INRUSH CURRENT (Typ.)	COLD START ≤40A/230V												
	LEAKAGE CURRENT	<3.5mA / 240VAC												
PROTECTION	OVERLOAD	105 ~ 150% rated output power Protection type : Hiccup mode, recovers automatically after fault condition is removed												
	OVER VOLTAGE	CH1:5.75 ~ 6.75V		CH2:3.8 ~ 4.4V Protection type : Shut down o/p voltage, re-power on to recover										
	OVER TEMPERATURE(OPTION)	Shut down o/p voltage, recovers automatically after temperature goes down												
ENVIRONMENT	WORKING TEMP.	-10 ~ +60°C (Refer to "Derating Curve")												
	WORKING HUMIDITY	20 ~ 90% RH non-condensing												
	STORAGE TEMP., HUMIDITY	-20 ~ +85°C, 10 ~ 95% RH non-condensing												
	TEMP. COEFFICIENT	± 0.03%/°C (0~50°C)												
	VIBRATION	10 ~ 500Hz, 2G 10min./1cycle, 60min. each along X, Y, Z axes												
SAFETY & EMC (Note 4)	SAFETY STANDARDS	UL60950-1, TUV EN60950-1, EAC TP TC 004 approved												
	WITHSTAND VOLTAGE	I/P-O/P:3KVAC		I/P-FG:2KVAC				O/P-FG:0.5KVAC						
	ISOLATION RESISTANCE	I/P-O/P, I/P-FG, O/P-FG:100M Ohms / 500VDC / 25°C / 70% RH												
	EMC EMISSION	Compliance to EN55032 (CISPR32) Class B, EN61000-3-2,-3, EAC TP TC 020												
	EMC IMMUNITY	Compliance to EN61000-4-2,3,4,5,6,8,11, EN55024, light industry level, criteria A, EAC TP TC 020												
OTHERS	MTBF	141.5K hrs min. MIL-HDBK-217F (25°C)												
	DIMENSION	199*99*50mm (L*W*H)												
	PACKING	0.93Kg; 20pcs/19.6Kg/1.28CUFT												
NOTE	<p>1. All parameters NOT specially mentioned are measured at 230VAC input, rated load and 25°C of ambient temperature.</p> <p>2. Ripple & noise are measured at 20MHz of bandwidth by using a 12" twisted pair-wire terminated with a 0.1uf & 47uf parallel capacitor.</p> <p>3. Tolerance : includes set up tolerance, line regulation and load regulation.</p> <p>4. The power supply is considered a component which will be installed into a final equipment. All the EMC tests are been executed by mounting the unit on a 360mm*360mm metal plate with 1mm of thickness. The final equipment must be re-confirmed that it still meets EMC directives. For guidance on how to perform these EMC tests, please refer to "EMI testing of component power supplies." (as available on http://www.meanwell.com)</p> <p>5. The ambient temperature derating of 3.5°C/1000m with fanless models and of 5°C/1000m with fan models for operating altitude higher than 2000m(6500ft).</p>													



■ Features :

- Universal AC input / Full range
- Built-in active PFC function, PF>0.95
- Protections: Short circuit / Overload / Over voltage
- Forced air cooling by built-in DC fan
- CH4:±Polarity is selectable
- Fixed switching frequency at 100KHz
- 3 years warranty



SPECIFICATION

MODEL		QP-150-3D				QP-150D				QP-150F			
OUTPUT	OUTPUT NUMBER	CH1	CH2	CH3	CH4	CH1	CH2	CH3	CH4	CH1	CH2	CH3	CH4
	DC VOLTAGE	5V	3.3V	24V	-12V	5V	12V	24V	-12V	5V	15V	24V	-15V
	RATED CURRENT	10A	10A	2.5A	0.6A	10A	4A	2A	0.6A	10A	3A	2A	0.6A
	CURRENT RANGE	3 ~ 15A	0 ~ 15A	0.3 ~ 3A	0 ~ 1A	3 ~ 15A	0 ~ 5A	0.4 ~ 3A	0 ~ 1A	3 ~ 15A	0 ~ 5A	0.4 ~ 3A	0 ~ 1A
	RATED POWER (max.)	150.2W				153.2W				152W			
	RIPPLE & NOISE (max.) Note.2	100mVp-p	100mVp-p	150mVp-p	150mVp-p	120mVp-p	150mVp-p	200mVp-p	150mVp-p	120mVp-p	150mVp-p	200mVp-p	150mVp-p
	VOLTAGE ADJ. RANGE	CH1: 4.75 ~ 5.5V		CH2: 3.14 ~ 3.63V		CH1: 4.75 ~ 5.5V		CH2: 11.4 ~ 13.2V		CH1: 4.75 ~ 5.5V		CH2: 14.3 ~ 16.5V	
	VOLTAGE TOLERANCE Note.3	± 3.0%	± 3.0%	± 6.0%	± 5.0%	± 3.0%	± 3.0%	± 6.0%	± 5.0%	± 3.0%	± 3.0%	± 6.0%	± 5.0%
	LINE REGULATION	± 1.0%	± 1.0%	± 2.0%	± 1.0%	± 1.0%	± 1.0%	± 2.0%	± 1.0%	± 1.0%	± 1.0%	± 2.0%	± 1.0%
	LOAD REGULATION	± 2.0%	± 2.0%	± 6.0%	± 2.0%	± 2.0%	± 2.0%	± 6.0%	± 2.0%	± 2.0%	± 2.0%	± 6.0%	± 2.0%
	SETUP, RISE TIME	800ms, 50ms/230VAC				1800ms, 50ms/115VAC at full load							
HOLD UP TIME (Typ.)	24ms/230VAC		24ms/115VAC at full load										
INPUT	VOLTAGE RANGE	90 ~ 264VAC		127 ~ 370VDC									
	FREQUENCY RANGE	47 ~ 63Hz											
	POWER FACTOR (Typ.)	PF>0.95/230VAC		PF>0.98/115VAC at full load									
	EFFICIENCY (Typ.)	76%				78%				78%			
	AC CURRENT (Typ.)	2.5A/115VAC		1.2A/230VAC									
	INRUSH CURRENT (Typ.)	COLD START ≤40A/230V											
	LEAKAGE CURRENT	<3.5mA / 240VAC											
PROTECTION	OVERLOAD	105 ~ 150% rated output power Protection type : Hiccup mode, recovers automatically after fault condition is removed											
	OVER VOLTAGE	CH1:5.75 ~ 6.75V		CH2:3.8 ~ 4.4V		CH1:5.75 ~ 6.75V		CH2:13.8 ~ 16.2V		CH1:5.75 ~ 6.75V		CH2:17.25 ~ 20.25V	
	OVER TEMPERATURE(OPTION)	Shut down o/p voltage, recovers automatically after temperature goes down											
ENVIRONMENT	WORKING TEMP.	-10 ~ +60°C (Refer to "Derating Curve")											
	WORKING HUMIDITY	20 ~ 90% RH non-condensing											
	STORAGE TEMP., HUMIDITY	-20 ~ +85°C , 10 ~ 95% RH non-condensing											
	TEMP. COEFFICIENT	± 0.03%/°C (0~50°C)											
	VIBRATION	10 ~ 500Hz, 2G 10min./1cycle, 60min. each along X, Y, Z axes											
SAFETY & EMC (Note 4)	SAFETY STANDARDS	UL60950-1, TUV EN60950-1, EAC TP TC 004 approved											
	WITHSTAND VOLTAGE	I/P-O/P:3KVAC I/P-FG:2KVAC O/P-FG:0.5KVAC											
	ISOLATION RESISTANCE	I/P-O/P, I/P-FG, O/P-FG:100M Ohms / 500VDC / 25°C / 70% RH											
	EMC EMISSION	Compliance to EN55032 (CISPR32) Class B, EN61000-3-2,-3, EAC TP TC 020											
	EMC IMMUNITY	Compliance to EN61000-4-2,3,4,5,6,8,11, EN55024, light industry level, criteria A, EAC TP TC 020											
OTHERS	MTBF	141.5K hrs min. MIL-HDBK-217F (25°C)											
	DIMENSION	199*99*50mm (L*W*H)											
	PACKING	0.93Kg; 20pcs/19.6Kg/1.28CUFT											
NOTE	<p>1. All parameters NOT specially mentioned are measured at 230VAC input, rated load and 25°C of ambient temperature.</p> <p>2. Ripple & noise are measured at 20MHz of bandwidth by using a 12" twisted pair-wire terminated with a 0.1uf & 47uf parallel capacitor.</p> <p>3. Tolerance : includes set up tolerance, line regulation and load regulation.</p> <p>4. The power supply is considered a component which will be installed into a final equipment. All the EMC tests are been executed by mounting the unit on a 360mm*360mm metal plate with 1mm of thickness. The final equipment must be re-confirmed that it still meets EMC directives. For guidance on how to perform these EMC tests, please refer to "EMI testing of component power supplies." (as available on http://www.meanwell.com)</p> <p>5. The ambient temperature derating of 3.5°C/1000m with fanless models and of 5°C/1000m with fan models for operating altitude higher than 2000m(6500ft).</p>												

Mechanical Specification

Case No. 916B Unit:mm

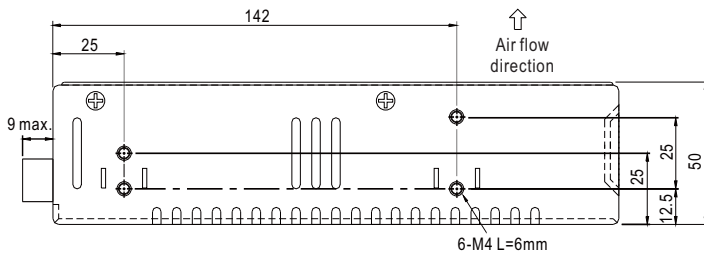
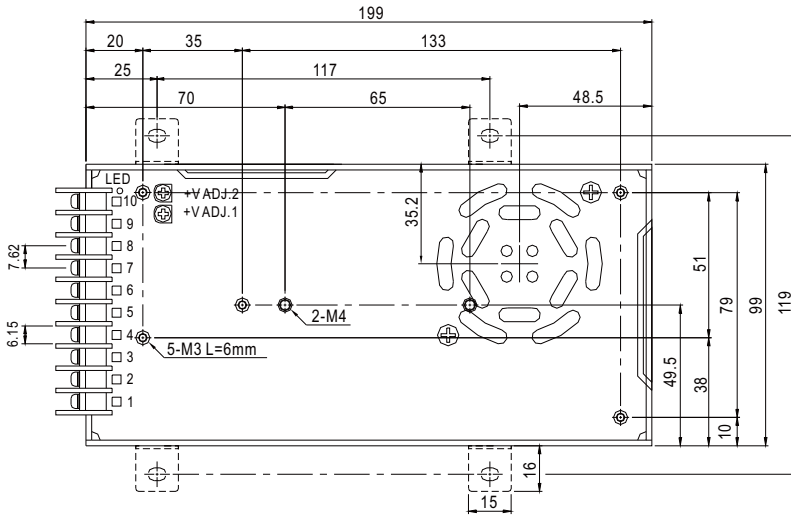

Terminal Pin No. Assignment :

Pin No.	Assignment	Pin No.	Assignment
1	AC/L	5	DC OUTPUT V3
2	AC/N	6,7	DC OUTPUT V1
3	FG \perp	8,9	DC OUTPUT COM
4	DC OUTPUT V4	10	DC OUTPUT V2

Block Diagram

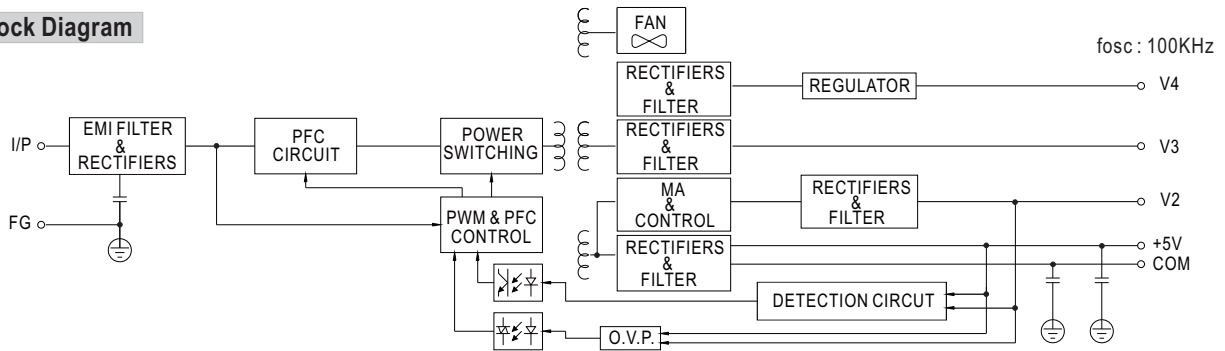

Derating Curve

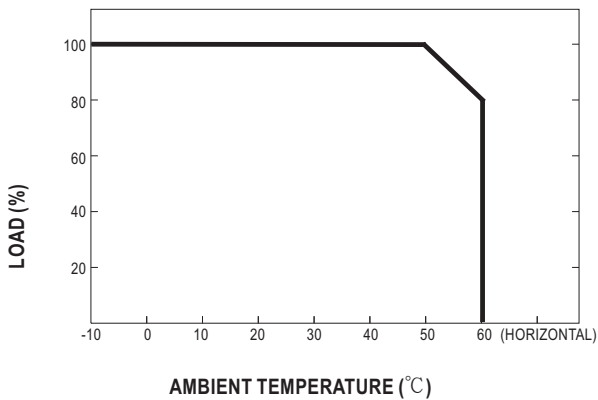

Output Derating VS Input Voltage

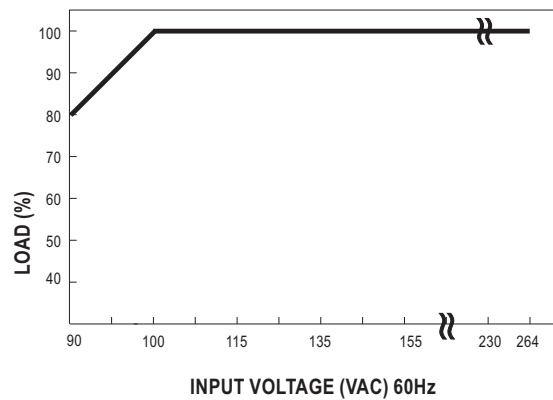



150W Quad Output with PFC Function

QP-150B,C series



■ Features :

- Universal AC input / Full range
- Built-in active PFC function, PF>0.95
- Protections: Short circuit / Overload / Over voltage
- Forced air cooling by built-in DC fan
- Fixed switching frequency at 100KHz
- 3 years warranty



SPECIFICATION

MODEL		QP-150B				QP-150C				
OUTPUT	OUTPUT NUMBER	CH1	CH2	CH3	CH4	CH1	CH2	CH3	CH4	
	DC VOLTAGE	5V	12V	-12V	-5V	5V	15V	-15V	-5V	
	RATED CURRENT	15A	4A	2A	0.6A	15A	3A	2A	0.6A	
	CURRENT RANGE	3 ~ 15A	0.4 ~ 5A	0.3 ~ 2A	0 ~ 1A	3 ~ 15A	0.4 ~ 4A	0.3 ~ 2A	0 ~ 1A	
	RATED POWER (max.)	150W				153W				
	RIPPLE & NOISE (max.) Note.2	100mVp-p	150mVp-p	150mVp-p	100mVp-p	100mVp-p	150mVp-p	150mVp-p	100mVp-p	
	VOLTAGE ADJ. RANGE	CH1:4.75 ~ 5.5V				CH1:4.75 ~ 5.5V				
	VOLTAGE TOLERANCE Note.3	± 3.0%	± 6.0%	+10,-6%	± 5.0%	± 3.0%	+6,-10%	± 8.0%	± 5.0%	
	LINE REGULATION	± 1.0%	± 2.0%	± 2.0%	± 1.0%	± 1.0%	± 2.0%	± 2.0%	± 1.0%	
	LOAD REGULATION	± 2.0%	± 6.0%	± 6.0%	± 2.0%	± 2.0%	± 6.0%	± 6.0%	± 2.0%	
SETUP, RISE TIME	1000ms, 50ms/230VAC		2200ms, 50ms/115VAC at full load							
HOLD UP TIME (Typ.)	24ms at full load									
INPUT	VOLTAGE RANGE	90 ~ 264VAC		127 ~ 370VDC						
	FREQUENCY RANGE	47 ~ 63Hz								
	POWER FACTOR (Typ.)	PF>0.95/230VAC		PF>0.98/115VAC at full load						
	EFFICIENCY (Typ.)	76%				77%				
	AC CURRENT (Typ.)	2.5A/115VAC		1.2A/230VAC						
	INRUSH CURRENT (Typ.)	COLD START ≤40A								
	LEAKAGE CURRENT	<3.5mA / 240VAC								
PROTECTION	OVERLOAD	105 ~ 135% rated output power Protection type : Hiccup mode, recovers automatically after fault condition is removed								
	OVER VOLTAGE	CH1:5.75 ~ 6.75V Protection type : Shut down o/p voltage, re-power on to recover								
	OVER TEMPERATURE(OPTION)	Shut down o/p voltage, recovers automatically after temperature goes down								
ENVIRONMENT	WORKING TEMP.	-10 ~ +60°C (Refer to "Derating Curve")								
	WORKING HUMIDITY	20 ~ 90% RH non-condensing								
	STORAGE TEMP., HUMIDITY	-20 ~ +85°C, 10 ~ 95% RH non-condensing								
	TEMP. COEFFICIENT	± 0.03%/°C (0~50°C)								
	VIBRATION	10 ~ 500Hz, 2G 10min./1cycle, 60min. each along X, Y, Z axes								
SAFETY & EMC (Note 4)	SAFETY STANDARDS	UL60950-1, TUV EN60950-1, EAC TP TC 004 approved								
	WITHSTAND VOLTAGE	I/P-O/P:3KVAC I/P-FG:2KVAC O/P-FG:0.5KVAC								
	ISOLATION RESISTANCE	I/P-O/P, I/P-FG, O/P-FG:100M Ohms / 500VDC / 25°C / 70% RH								
	EMC EMISSION	Compliance to EN55032 (CISPR32) Class B, EN61000-3-2,-3, EAC TP TC 020								
	EMC IMMUNITY	Compliance to EN61000-4-2,3,4,5,6,8,11, EN55024, light industry level, criteria A, EAC TP TC 020								
OTHERS	MTBF	141.5K hrs min. MIL-HDBK-217F (25°C)								
	DIMENSION	199*99*50mm (L*W*H)								
	PACKING	1.1Kg; 20pcs/22Kg/1.28CUFT								
NOTE	<p>1. All parameters NOT specially mentioned are measured at 230VAC input, rated load and 25°C of ambient temperature.</p> <p>2. Ripple & noise are measured at 20MHz of bandwidth by using a 12" twisted pair-wire terminated with a 0.1uf & 47uf parallel capacitor.</p> <p>3. Tolerance : includes set up tolerance, line regulation and load regulation.</p> <p>4. The power supply is considered a component which will be installed into a final equipment. All the EMC tests are been executed by mounting the unit on a 360mm*360mm metal plate with 1mm of thickness. The final equipment must be re-confirmed that it still meets EMC directives. For guidance on how to perform these EMC tests, please refer to "EMI testing of component power supplies." (as available on http://www.meanwell.com)</p> <p>5. The ambient temperature derating of 3.5°C/1000m with fanless models and of 5°C/1000m with fan models for operating altitude higher than 2000m(6500ft).</p>									

Mechanical Specification

Case No. 916B Unit:mm

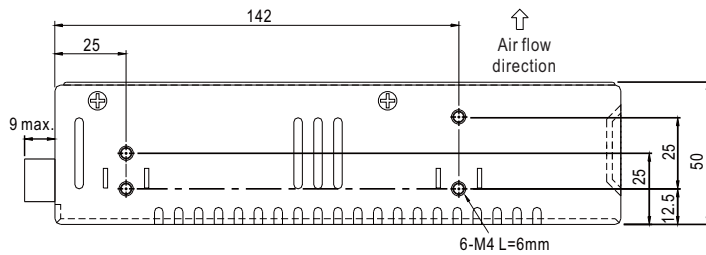
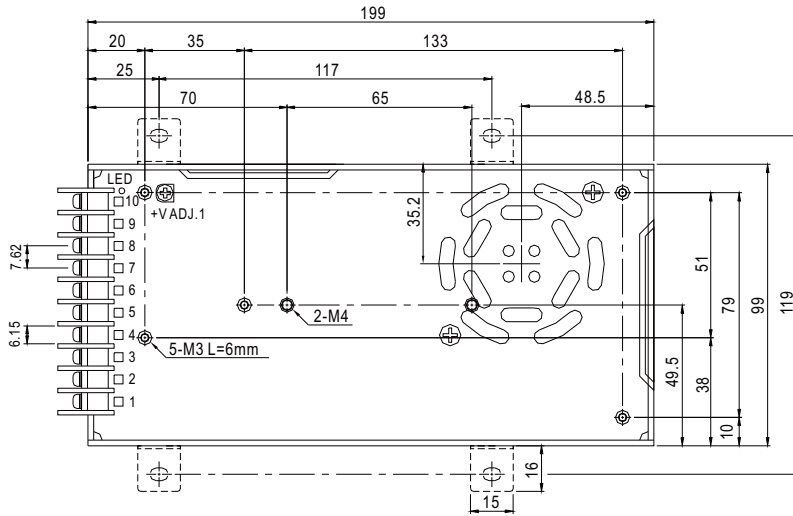

Terminal Pin No. Assignment :

Pin No.	Assignment	Pin No.	Assignment
1	AC/L	5	DC OUTPUT V3
2	AC/N	6,7	DC OUTPUT V1
3	FG	8,9	DC OUTPUT COM
4	DC OUTPUT V4	10	DC OUTPUT V2

Block Diagram

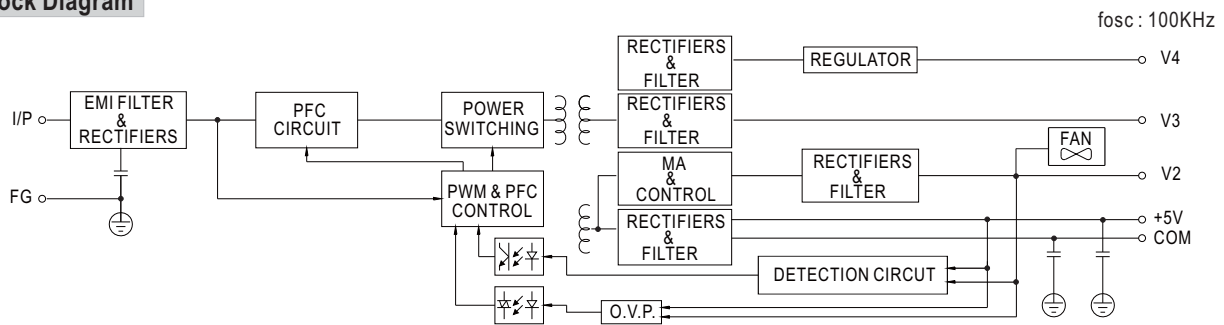

Derating Curve

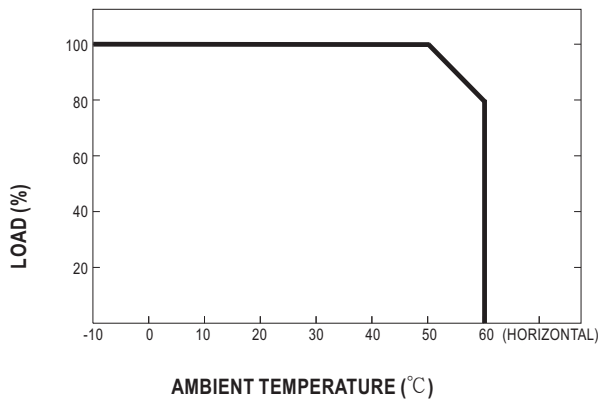

Output Derating VS Input Voltage

