



Chipsmall Limited consists of a professional team with an average of over 10 year of expertise in the distribution of electronic components. Based in Hongkong, we have already established firm and mutual-benefit business relationships with customers from,Europe,America and south Asia,supplying obsolete and hard-to-find components to meet their specific needs.

With the principle of “Quality Parts,Customers Priority,Honest Operation,and Considerate Service”,our business mainly focus on the distribution of electronic components. Line cards we deal with include Microchip,ALPS,ROHM,Xilinx,Pulse,ON,Everlight and Freescale. Main products comprise IC,Modules,Potentiometer,IC Socket,Relay,Connector.Our parts cover such applications as commercial,industrial, and automotives areas.

We are looking forward to setting up business relationship with you and hope to provide you with the best service and solution. Let us make a better world for our industry!



Contact us

Tel: +86-755-8981 8866 Fax: +86-755-8427 6832

Email & Skype: info@chipsmall.com Web: www.chipsmall.com

Address: A1208, Overseas Decoration Building, #122 Zhenhua RD., Futian, Shenzhen, China



Evaluation Board for QPO-2 Active Output Filter

The QPO-2-EVAL1 board provides an easy to use evaluation platform for testing the QPO-2 in a low-voltage system. A filtered voltage range of 0.3 Vdc to 5.5 Vdc at output load currents up to 20A can be accomplished. A low current bias supply is required at the VAUX input in the range of 7 to 12 volts respectively to the output voltage range. The board comes with a QPO-2LZ and some essential external components pre-mounted. Please refer to the QPO-2 datasheet for product details. Terminals for horizontal or vertical mounting are also provided. The user must mount and select component values for RHR, RSC, RSL and RSA based on their system needs.

RCP will preset the QPO-2's reference voltage to a value close to the desired steady-state value. This reduces the time required for the QPO-2's output to reach the steady-state output voltage. There is a provision for a start-up circuit (Q1 RDLY D1 CDLY) if the initial headroom voltage needs to start from zero and increase gradually to the set headroom voltage. Remote sense components (CRS RRS), Figure 3 of the product datasheet, are mounted on the evaluation board.

When remote sensing is not used RSC is the current programming resistor that determines the current sourced by the QPO-2's Adjust+ pin to drive the TRIM pin of a

converter. The RSL resistor shown in Figure 4 of the product datasheet (not on the evaluation board) can be used to limit the correction current sourced from the Adjust+ circuit if needed during start-up preventing the converter from tripping OVP.

RHR is the headroom voltage setting resistor that will determine the voltage dropped across the QPO-2. The RSA resistor is for the slope-adjust option, which can be used to reduce the amount of voltage across the QPO-2 depending on load current. This reduced drop in voltage will result in a lower power loss across the QPO-2 providing greater efficiency but lower attenuation. An optional capacitor, CHR, can be added to extend the low-frequency attenuation range of the QPO-2.

The RP resistor connects the QPO-2's peak detection circuit to the input voltage rail. The peak detector will adapt the headroom voltage by adding half the peak-to-peak ripple voltage to the headroom. Internally, the QPO-2 has a 0.1uF capacitor on its peak detector pin that allows the user to filter out the converter's ripple with an appropriate RP resistor value, disabling the peak detector. This filtering is enabled by using a low resistance value for RP, such as a zero ohm that comes pre-installed on the QPO-2 Eval board.

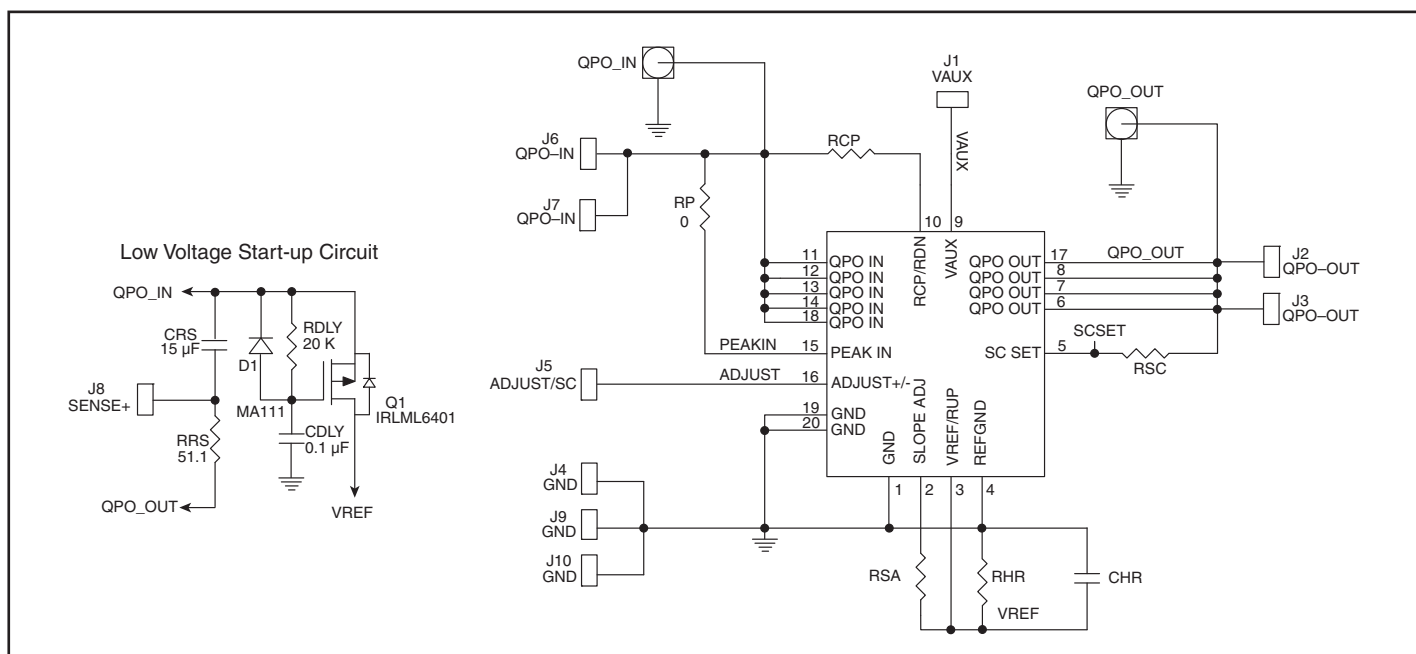

Figure 1 - Evaluation board schematic

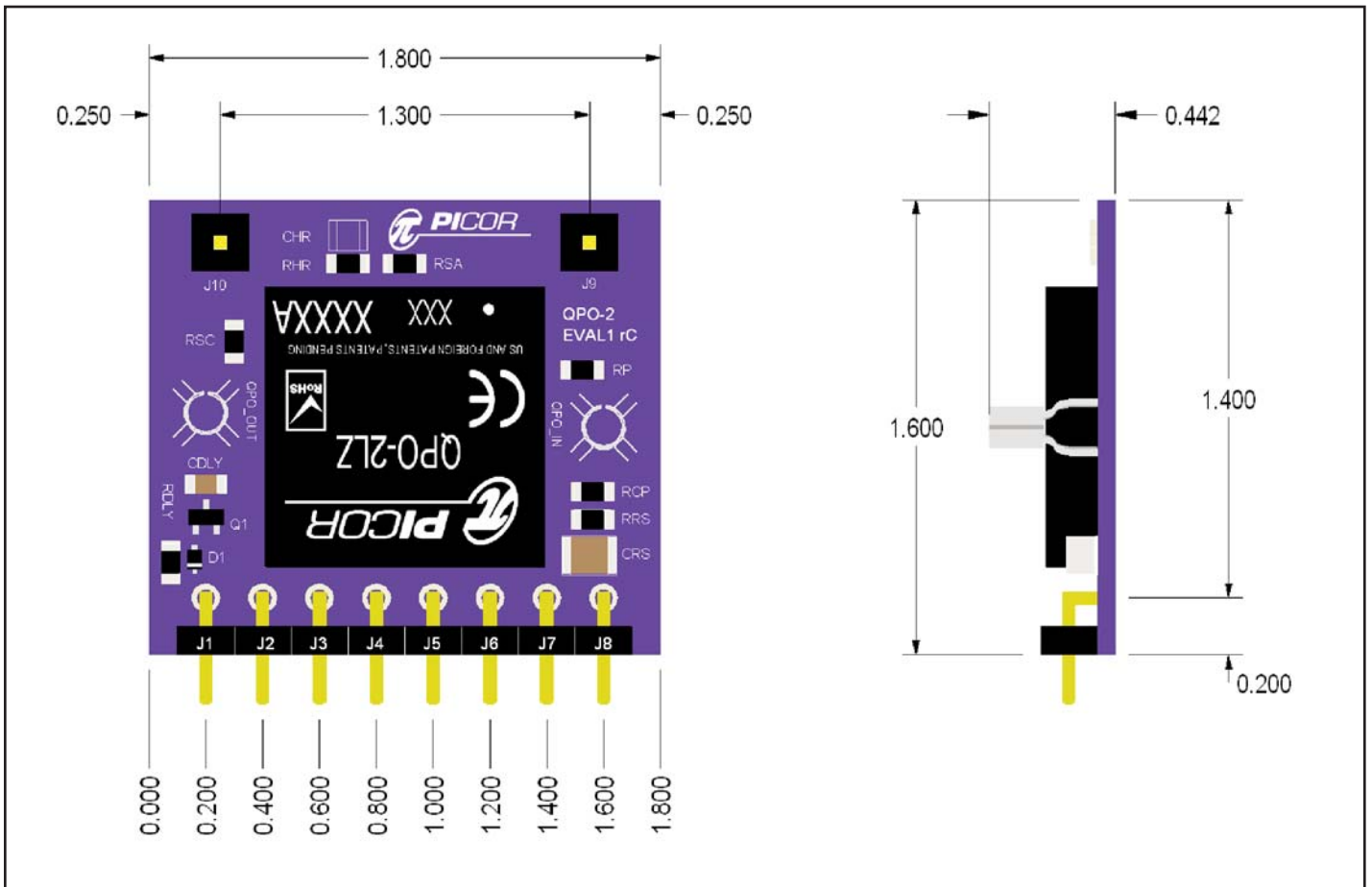

Figure 2 - Figure 2 – Evaluation Board Layout

* Note: Components Q1, D1, RDLY and CDLY are for an optional start-up circuit.

Ordering Information

Part Number	Description
QPO-2-EVAL1	Evaluation board for QPO-2LZ

Vicor's comprehensive line of power solutions includes high-density AC-DC & DC-DC modules and accessory components, fully configurable AC-DC & DC-DC power supplies, and complete custom power systems.

Information furnished by Vicor is believed to be accurate and reliable. However, no responsibility is assumed by Vicor for its use. No license is granted by implication or otherwise under any patent or patent rights of Vicor. Vicor components are not designed to be used in applications, such as life support systems, wherein a failure or malfunction could result in injury or death. All sales are subject to Vicor's Terms and Conditions of Sale, which are available upon request.

Specifications are subject to change without notice.



Vicor Corporation
 25 Frontage Road, Andover, MA, USA 01810
 Tel: 800-735-6200 Fax: 978-475-6715

Email
 Vicor Express: vicorexp@vicr.com
 Technical Support: apps@vicr.com