



Chipsmall Limited consists of a professional team with an average of over 10 year of expertise in the distribution of electronic components. Based in Hongkong, we have already established firm and mutual-benefit business relationships with customers from,Europe,America and south Asia,supplying obsolete and hard-to-find components to meet their specific needs.

With the principle of “Quality Parts,Customers Priority,Honest Operation,and Considerate Service”,our business mainly focus on the distribution of electronic components. Line cards we deal with include Microchip,ALPS,ROHM,Xilinx,Pulse,ON,Everlight and Freescale. Main products comprise IC,Modules,Potentiometer,IC Socket,Relay,Connector.Our parts cover such applications as commercial,industrial, and automotives areas.

We are looking forward to setting up business relationship with you and hope to provide you with the best service and solution. Let us make a better world for our industry!



Contact us

Tel: +86-755-8981 8866 Fax: +86-755-8427 6832

Email & Skype: info@chipsmall.com Web: www.chipsmall.com

Address: A1208, Overseas Decoration Building, #122 Zhenhua RD., Futian, Shenzhen, China



- Rotary finger-touch 'wheel' slider control
- Extremely simple circuit - no external active components
- Completely passive sensing element: no moving parts
- Compatible with clear ITO over LCD construction
- SPI slave-mode interface
- Self-calibration and drift compensation modes
- Proximity sensing for wake up function
- Spread-spectrum operation for optimal EMC compliance
- 2.5 - 5.5V single supply operation; very low power
- 14-pin SOIC and TSSOP Pb-free packages
- Inexpensive, simple 1-sided PCB construction possible
- E510 reference design board available

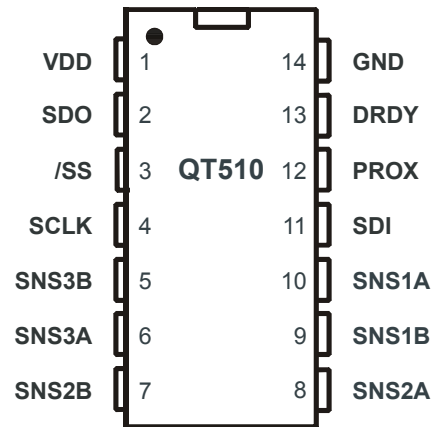

APPLICATIONS

- Personal electronics
- Appliance controls
- Shaft encoders
- Automotive controls

The QT510 QSlide™ IC is a new type of rotary capacitive touch 'slider' sensor IC based on Quantum's patented charge-transfer methods. This unique IC allows designers to create speed or volume controls, menu bars, and other more exotic forms of human interface on the panel of an appliance. Generally it can be used to replace any form of rotary knob, through a completely sealed panel.

The device uses a simple, inexpensive resistive sensing element between three connection points. The sense element can be circular or any polygon shape. The sense element can also be used as a proximity sensor out to several centimeters, to wake up an appliance or display from a sleep mode in a dramatic fashion.

The QT510 can report a single rapid touch anywhere along the sense element, or, it can track a finger moving along the wheel surface in real time. The device self-calibrates under command from a host controller.

This device uses three channels of simultaneous sensing across a resistive element to determine finger position, using mathematical analysis. A positional accuracy of 5% (or better) is relatively easy to achieve.

The acquisitions are performed in a burst mode which uses proprietary spread-spectrum modulation for superior noise immunity and low emissions.

The output of the QT510 can also be used to create discrete controls in a circle, by interpreting sets of number ranges as buttons. For example, the number range 0..19 can be button A, 30..49 button B, 60..79 button C etc. Continuous wheel action and discrete controls can be mixed on a single element, or, the element can be reinterpreted differently at different times, for example when used below or on top of an LCD to act as a menu input device that dynamically changes function in context. The device is compatible with ITO (Indium Tin Oxide) overlays on top of various displays or simply to provide for a backlighting effect.

AVAILABLE OPTIONS

T _A	SO-14	TSSOP-14
-40°C ~ +85°C	QT510-ISG	QT510-ISSG

1 Operation

The QT510 uses a SPI slave mode interface for control and data communications with a host controller. Acquisition timings and operating parameters are under host control; there are no option jumpers and the device cannot operate in a stand-alone mode.

The positional output data is a 7-bit binary number (0...127) indicating angular position.

Like all QProx™ devices, the QT510 operates using bursts of charge-transfer pulses; burst mode permits an unusually high level of control over spectral modulation, power consumption, and response time.

The QT510 modulates its bursts in a spread-spectrum fashion in order to heavily suppress the effects of external noise, and to suppress RF emissions.

1.1 Synchronized Mode

Refer also to Figure 3-1, page 6.

Sync mode allows the host device to control the repetition rate of the acquisition bursts, which in turn govern response time and power consumption. The maximum spacing from the end of one burst to the start of the next in this mode is 1 sec.

In sync mode, the device will wait for the SPI slave select line /SS to fall and rise and will then do an acquisition burst; actual SPI clocks and data are optional. The /SS pin thus becomes a 'sync' input in addition to acting as the SPI framing control.

Within 35µs of the last rising edge of CLK, the device will enter a low power sleep mode. The rising edge of /SS must occur after this time; when /SS rises, the device wakes from sleep, and shortly thereafter does an acquisition burst. If a more substantial sleep time is desired, /SS should be made to rise some delay period later.

By increasing the amount of time spent in sleep mode, the host can decrease the average current drain at the expense of response time. Since a burst typically requires 31ms (at 3.3V, reference circuit), and an acceptable response time might be ~100ms, the power duty cycle will be 31/100 or 31% of peak current.

Figure 1-1 QT510 Wiring Diagram

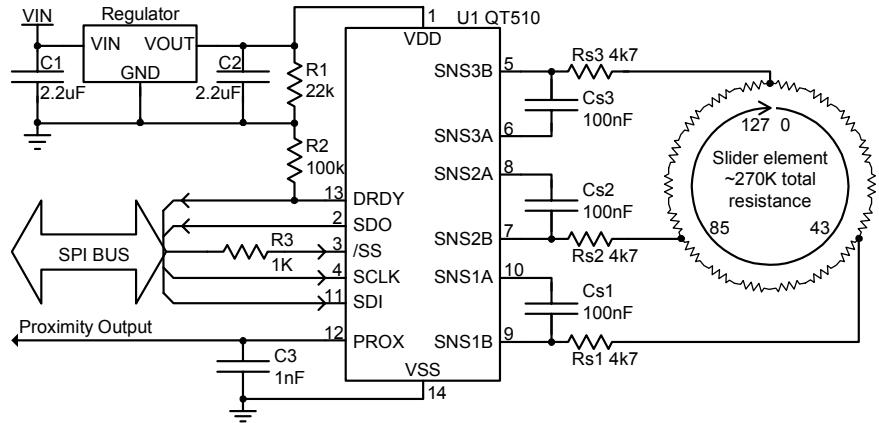

If power is not an issue the device can run constantly under host control, by always raising /SS after 35µs from the last rising edge of CLK. Constant burst operation can be used by the host to gather more data to filter the position data further to suppress noise effects, if required.

Synchronized mode also allows the host device to control the rate of drift compensation, by periodically sending a 'drift' command to the device.

Mains Sync: Sync mode can and should be used to sync to mains frequency via the host controller, if mains interference is possible (ie, running as a lamp dimmer control). The host should issue SPI commands synchronously with the mains frequency. This form of operation will heavily suppress interference from low frequency sources (e.g. 50/60Hz), which are not easily suppressed using spread-spectrum pulse modulation.

Cross-talk suppression: If two or more QT510's are used in close proximity, or there are other QTTouch™ type device(s) close by, the devices can interfere strongly with one another to create position jitter or false triggering. This can be suppressed by making sure that the devices do not perform acquisition bursts at overlapping times. The host controller can make sure that all such devices operate in distinctly different timeslots, by using a separate /SS line for each part.

1.2 Free-Run Mode

If /SS stays high, the device will acquire on its own repetitively approximately every 60ms (Figure 1-2). This mode can be used to allow the part to function as a prox

Figure 1-2 Free-Run Timing Diagram (/SS = high)

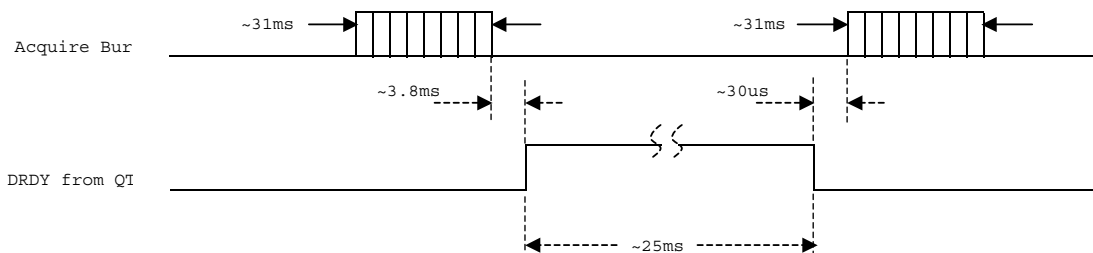

Table 1-1 Pin Descriptions

PIN	NAME	TYPE	DESCRIPTION
1	VDD	Power	Positive power pin (+2.5 .. +5V)
2	SDO	O	Serial data output
3	/SS	I	Slave Select pin. This is an active low input that enables serial communications
4	SCLK	I	Serial clock input. Clock idles high
5	SNS3B	I/O	Sense pin (to Cs3, Rs3); connects to 127/0 position (12:00) of wheel
6	SNS3A	I/O	Sense pin (to Cs3)
7	SNS2B	I/O	Sense pin (to Cs2, Rs2); connects to 85 position (8:00) of wheel
8	SNS2A	I/O	Sense pin (to Cs2)
9	SNS1B	I/O	Sense pin (to Cs1, Rs1); connects to 43 position (4:00) of wheel
10	SNS1A	I/O	Sense pin (to Cs1)
11	SDI	I	Serial data input
12	PROX	O	Active high when hand approaches and during touch. May be left unconnected. Note (1)
13	DRDY	O	Data ready output. Goes high to indicate it is possible to communicate with the QT510. Note (1)
14	VSS	Ground	Negative power pin

Note (1): Pin floats ~400µs after wake from Sleep mode.

detector first, perhaps to wake a host controller. The PROX pin can be used to wake up the host when it goes high.

In free-run mode, the device does not sleep between bursts. In this mode the QT510 performs automatic drift compensation at the maximum rate of one count per 180 acquisition burst cycles, or about one count every 3 seconds without host intervention. It is not possible to change this setting of drift compensation in Free-Run mode. See also Section 3.3.3.

1.3 Sleep Mode

After an SPI transmission, the device will enter a low power sleep state; see Figure 3-1, page 6, and Section 3.2.4, page 7 for details. This sleep state can be extended in order to lower average power, by simply delaying the rise of /SS.

Coming out of sleep state when /SS rises, the PROX and DRDY pins will float for ~400µs; it is recommended that these pins be pulled low to Vss to avoid false signalling if they being monitored during this time.

Note: Pin /SS clamps to Vss for 250ns after coming out of sleep state as a diagnostic pulse. To prevent a possible pin drive conflict, /SS should either be driven by the host as an open-drain pull-high drive (e.g. with a 100K pullup resistor), or there should be a ~1K resistor placed in series with the /SS pin. See Figure 1-1.

N.B Activity on the clock line will wake the QT510, which in turn will then wait for the SS to rise.

1.4 PROX Output

There is an active-high output pin for the detection of hand proximity.

PROX output: This pin goes high when a hand is detected in free space near the slider. This condition is also found as bit 0 in the standard response when there is no touch detection (Section 3.3).

The sensitivity of this function can be set using serial commands (Sections 3.3.4 and 3.3.5).

This output will float for ~400µs after wake from Sleep mode (see Section 1.3). It is recommended that PROX (if used) be shunted to ground with 1nF capacitors to hold its state during the 400µs float interval when emerging from Sleep.

1.5 Position Data

The position value is internally calculated and can be accessed only when the sensor is touched (Detect pin high).

The position data is a 7-bit number (0..127) that is computed in real time; the position number returned is 0 or 127 with position at SNS3, 43 when at SNS1 and 85 at SNS2. The position data will update either with a single rapid touch or will track if the finger is moved along the surface of the element. The position data ceases to be reported when touch detection is no longer sensed.

1.6 Calibration

Calibration is possible via two methods:

- 1) Power up or power cycling (there is no reset input).
- 2) On command from host via SPI (Command 0x01: see Section 3.3.2).

The calibration period requires 10 burst cycles, which are executed automatically without the need for additional SPI commands from the host. The spacing between each Cal burst is 1.5ms, and the bursts average about 31ms each, i.e. the Cal command requires ~325ms to execute.

Calibration should be performed when there is no hand proximity to the element, or the results may be in error. Should this happen, the error flag (bit 1 of the standard response, see Section 3.3) will activate when the hand is withdrawn. In most cases this condition will self-correct if drift compensation is used, and it can thus be ignored. See Section 1.8 below.

Note: During calibration, the device cannot communicate. DRDY will remain low during this interval.

1.7 Drift Compensation

The device features an ability to compensate for slow drift due to environmental factors such as temperature changes or humidity. Drift compensation is performed completely under host control via a special drift command. See Section 3.3.3 for further details.

1.8 Error Flag

An error flag bit is provided in the standard response byte but only when there is no touch detection present (Section 3.3); if

Figure 1-3 E510 PCB Layout

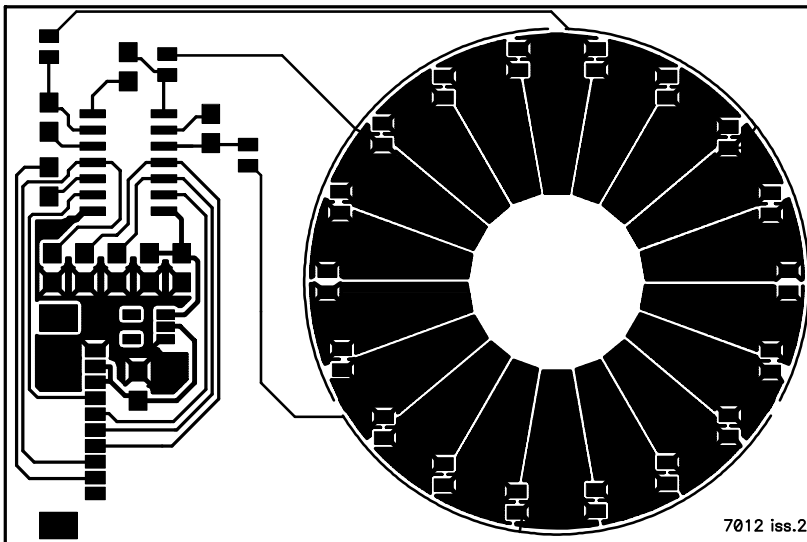

the Error bit is high, it means the signal has fallen significantly below the calibration level when not touched. If this happens the device could report slightly inaccurate position values when touched.

This condition can self-correct via the drift compensation process after some time under host control (Section 3.3.3). Alternatively, the host controller can cause the device to recalibrate immediately by issuing a calibration command (Section 3.3.2).

2 Wiring & Parts

The device should be wired according to Figure 1-1. An example PCB layout (of the E510 eval board) is shown in Figure 1-3.

2.1 Electrode Construction

The wheel electrode should be a resistive element of about 100K ohms +/-50% between each set of connection points, of a suitable diameter and width. There are no known diameter restrictions other than those governed by human factors.

The electrode can be made of a series chain of discrete resistors with copper pads on a PCB, or from ITO (Indium Tin Oxide, a clear conductor used in LCD panels and touch screens) over a display. Thick-film carbon paste can also be used, however linearity might be a problem as these films are notoriously difficult to control without laser trimming or scribing.

The linearity of the wheel is governed largely by the linearity and consistency of the resistive element. Positional accuracy to within 5% is routinely achievable with good grade resistors and a uniform construction method.

2.2 Cs Sample Capacitors

Cs1, Cs2 and Cs3 are the charge sensing sample capacitors; normally they are identical in nominal value. They should be of type X7R dielectric.

The optimal Cs values depend on the thickness of the panel and its dielectric constant. Lower coupling to a finger caused by a low dielectric constant and/or thicker panel will cause the position result to become granular and more subject to position errors. The ideal panel is made of thin glass. The worst panel is thick plastic. Granularity due to poor coupling can be compensated for by the use of larger values of sample capacitors.

A table of suggested values for no missing position values is shown in Table 1-2. Values of Cs smaller than those shown in the table can cause skipping of position codes. Code skipping may be acceptable in many applications where fine position data is not required. Smaller Cs capacitors have the advantage of requiring shorter acquisition bursts and hence lower power drain.

Larger values of Cs improve granularity at the expense of longer burst lengths and

hence more average power.

Cs1, Cs2 and Cs3 should be X7R type, matched to within 10% of each other (ie, 5% tolerance) for best accuracy. The E510 reference layout (Figure 1-3) is highly recommended. If the Cs capacitors are poorly matched, the wheel accuracy will be affected and there could also be missing codes.

2.3 Rs Resistors

Rs1, Rs2, and Rs3 are low value (typically 4.7K) resistors used to suppress the effects of ESD and assist with EMC compliance.

2.4 Power Supply

The usual power supply considerations with QT parts applies also to the QT510. The power should be very clean and come from a separate regulator if possible. This is particularly critical with the QT510 which reports continuous position as opposed to just an on/off output.

A ceramic 0.1µF bypass capacitor should be placed very close to the power pins of the IC.

Regulator stability: Most low power LDO regulators have very poor transient stability, especially when the load transitions from zero current to full operating current in a few microseconds. With the QT510 this happens when the device comes out of sleep mode. The regulator output can suffer from hundreds of microseconds of instability at this time, which will have a negative effect on acquisition accuracy.

Table 1-2 Recommended Cs vs. Materials

Thickness, mm	Acrylic ($\epsilon_R=2.8$)	Borosilicate glass ($\epsilon_R=4.8$)
0.4	10nF	5.6nF
0.8	22nF	10nF
1.5	47nF	22nF
2.5	100nF	39nF
3.0	-	47nF
4.0	-	100nF

To assist with this problem, the QT510 waits 500µs after coming out of sleep mode before acquiring to allow power to fully stabilize. This delay is not present before an acquisition burst if there is no preceding sleep state.

Use an oscilloscope to verify that Vdd has stabilized to within 5mV or better of final settled voltage before a burst begins.

2.5 PCB Layout and Mounting

The E510 PCB layout (Figure 1-3) should be followed if possible. This is a 1-sided board; the blank side is simply adhered to the inside of a 2mm thick (or less) control panel. Thicker panels can be tolerated with additional position error due to capacitive 'hand shadow' effects and will also have poorer EMC performance.

This layout uses 18 copper pads connected with intervening series resistors in a circle. The finger interpolates between the copper pads (if the pads are narrow enough) to make a smooth, 0..127 step output with no apparent stair-casing. The lateral dimension along the centre of each electrode should be no wider than the expected smallest diameter of finger touch, to prevent stair-casing of the position response (if that matters).

Other geometries are possible, for example triangles and squares. The wheel can be made in various diameters up to at least 80mm. The electrode width should be about 12mm wide or more, as a rule.

The SMT components should be oriented perpendicular to the direction of bending so that they do not fracture when the PCB is flexed during bonding to the panel.

Additional ground area or a ground plane on the PCB will compromise signal strength and is to be avoided. A single sided PCB can be made of FR-2 or CEM-1 for low cost.

'Handshadow' effects: With thicker and wider panels an effect known as 'handshadow' can become noticeable. If the capacitive coupling from finger to electrode element is weak, for example due to a narrow electrode width or a thick, low dielectric constant panel, the remaining portion of the human hand can contribute a significant portion of the total detectable capacitive load. This will induce an offset error, which will depend on the proximity and orientation of the hand to the remainder of the element. Thinner panels and those with a smaller diameter will reduce this effect since the finger contact surface will strongly dominate the total signal, and the remaining handshadow capacitance will not contribute significantly to create an error offset.

PCB Cleanliness: All capacitive sensors should be treated as highly sensitive circuits which can be influenced by stray conductive leakage paths. QT devices have a basic resolution in the femtofarad range; in this region, there is no such thing as 'no clean flux'. Flux absorbs moisture and becomes conductive between solder joints, causing signal drift and resultant false detections or temporary loss of sensitivity. Conformal coatings will trap in existing amounts of moisture which will then become highly temperature sensitive.

The designer should specify ultrasonic cleaning as part of the manufacturing process, and in extreme cases, the use of conformal coatings after cleaning.

2.6 ESD Protection

Since the electrode is always placed behind a dielectric panel, the IC will be protected from direct static discharge. However even with a panel transients can still flow into the electrode via induction, or in extreme cases via dielectric breakdown. Porous materials may allow a spark to tunnel right through the material. Testing is required to reveal any problems. The device has diode protection on its terminals which will absorb and protect the device from most ESD events; the usefulness of the internal clamping will depend on the panel's dielectric properties and thickness.

One method to enhance ESD suppression is to insert resistors Rs1, Rs2 and Rs3 in series with the element as shown in Figure 1-1; these are typically 4.7K but can be as high as 10K ohms.

Diodes or semiconductor transient protection devices or MOV's on the electrode traces are not advised; these devices have extremely large amounts of nonlinear parasitic capacitance which will swamp the capacitance of the electrode and cause false detections and other forms of instability. Diodes also act as RF detectors and will cause serious RF immunity problems.

See also next section.

2.7 EMC and Related Noise Issues

External AC fields (EMI) due to RF transmitters or electrical noise sources can cause false detections or unexplained shifts in sensitivity.

The influence of external fields on the sensor can be reduced by means of the Rs series resistors described in Section 2.6. The Cs capacitor and the Rs resistors (Figure 1-1) form a natural low-pass filter for incoming RF signals; the roll-off frequency of this network is defined by -

$$F_R = \frac{1}{2\pi R_S C_S}$$

If for example Cs = 47nF, and Rs = 4.7K, the EMI rolloff frequency is ~720 Hz, which is much lower than most noise sources (except for mains frequencies i.e. 50 / 60 Hz). The resistance from the sensing element itself is actually much higher on average, since the element is typically 50K ~ 100K ohms between connection points.

Rs and Cs must both be placed very close to the body of the IC so that the lead lengths between them and the IC do not form an unfiltered antenna at very high frequencies.

PCB layout, grounding, and the structure of the input circuitry have a great bearing on the success of a design to withstand electromagnetic fields and be relatively noise-free.

These design rules should be adhered to for best ESD and EMC results:

1. Use only SMT components.
2. Keep all Cs, Rs, and the Vdd bypass cap close to the IC.
3. Do not place the electrode or its connecting trace near other traces, or near a ground plane.
4. Do use a ground plane under and around the QT510 itself, back to the regulator and power connector (but not beyond the Cs capacitor).
5. Do not place an electrode (or its wiring) of one QT510 device near the electrode or wiring of another device, to

prevent cross interference, unless they are synchronized.

6. Keep the electrode (and its wiring) away from other traces carrying AC or switched signals.
7. If there are LEDs or LED wiring near the electrode or its wiring (ie for backlighting of the key), bypass the LED wiring to ground on both the anode and cathode.
8. Use a voltage regulator just for the QT510 to eliminate noise coupling from other switching sources via Vdd. Make sure the regulator's transient load stability provides for a stable voltage just before each burst commences.
9. If Mains noise (50/60 Hz noise) is present, use the Sync feature to suppress it (see Section 1.1).

For further tips on construction, PCB design, and EMC issues browse the application notes and faq at www.qprox.com

3 Serial Communications

The serial interface is a SPI slave-only mode type which is compatible with multi-drop operation, ie the MISO pin will float after a shift operation to allow other SPI devices (master or slave) to talk over the same bus. There should be one dedicated /SS line for each QT510 from the host controller.

A DRDY ('data ready') line is used to indicate to the host controller when it is possible to talk to the QT510.

3.1 Power-up Timing Delay

Immediately after power-up, DRDY floats for approximately 20ms, then goes low. The device requires ~520ms thereafter before DRDY goes high again, indicating that the device has calibrated and is able to communicate.

3.2 SPI Timing

The SPI interface is a five-wire slave-only type; timings are found in Figure 3-1. The phase clocking is as follows:

Clock idle:	High
Data out changes on:	Falling edge of CLK from host
Input data read on:	Rising edge of CLK from host
Slave Select /SS:	Negative level frame from host
Data Ready DRDY:	Low from QT inhibits host
Bit length & order:	8 bits, MSB shifts first
Clock rate:	5kHz min, 40kHz max

The host can shift data to and from the QT on the same cycle (with overlapping commands). Due to the nature of SPI, the

Figure 3-1 SPI Timing Diagram

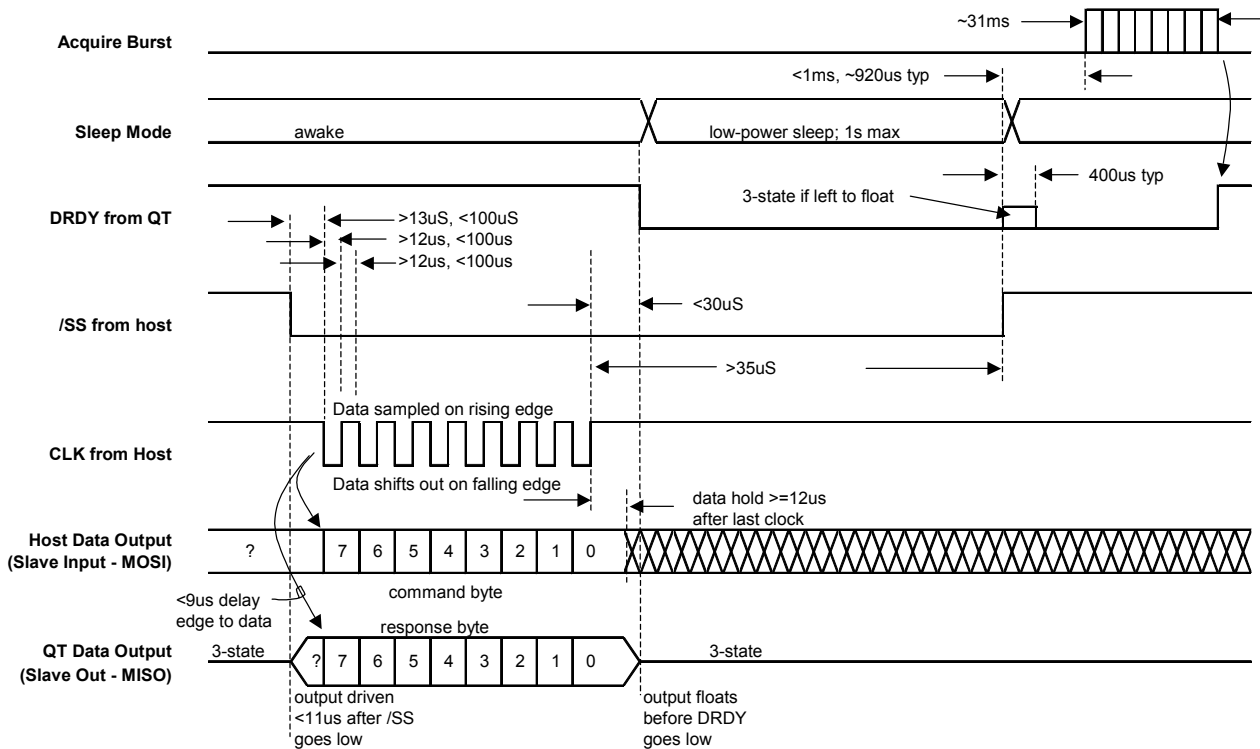

return data from a command or action is always one SPI cycle behind.

An acquisition burst always happens about 920µs after /SS goes high after coming out of Sleep mode. SPI clocking lasting more than 15ms can cause the chip to self-reset.

3.2.1 /SS Line

/SS acts as a framing signal for SPI data clocking under host control. See Figure 3-1.

After a shift operation /SS must go high again, a minimum of 35µs after the last clock edge on CLK. The device automatically goes into sleep state during this interval, and wakes again after /SS rises. If /SS is simply held low after a shift operation, the device will remain in sleep state up to the maximum time shown in Figure 3-1. When /SS is raised, another acquisition burst is triggered.

If /SS is held high all the time, the device will burst in a free-running mode at a ~17Hz rate. In this mode a valid position result can be obtained quickly on demand, and/or one of the two OUT pins can be used to wake the host. This rate depends on the burst length which in turn depends on the value of each Cs and load capacitance Cx. Smaller values of Cs or higher values of Cx will make this rate faster.

Dummy /SS Burst Triggers: In order to force a single burst, a dummy 'command' can be sent to the device by pulsing /SS low for 10µs to 10ms; this will trigger a burst on the rising edge of /SS without requiring an actual SPI transmission. DRDY will fall within 56µs of /SS rising again, and then a burst will occur 1ms later (while DRDY stays low).

After the burst completes, DRDY will rise again to indicate that the host can get the results.

Note: Pin /SS clamps to Vss for 250ns after coming out of sleep state as a diagnostic pulse. To prevent a possible pin drive conflict, /SS should either be driven by the host as an open-drain pull-high drive (e.g. with a 100K pullup resistor), or there should be a ~1K resistor placed in series with the /SS pin.

3.2.2 DRDY Line

The DRDY line acts primarily as a way to inhibit the host from clocking to the QT510 when the QT510 is busy. It also acts to signal to the host when fresh data is available after a burst. The host should not attempt to clock data to the QT510 when DRDY is low, or the data will be ignored or cause a framing error.

On power-up, DRDY will first float for about 20ms, then pull low for ~525ms until the initial calibration cycle has completed, then drive high to indicate completion of calibration. The device will be ready to communicate in typically under 600ms (with Cs1 = Cs2 = 100nF).

While DRDY is a push-pull output; however, this pin floats after power-up and after wake from Sleep mode, for ~400µs (typical at Vdd = 3.3V). It is desirable to use a pulldown resistor on DRDY to prevent false signalling back to the host controller; see Figure 1-1 and Section 1.3.

3.2.3 MISO / MOSI Data Lines

MISO and MOSI shift on the falling edge of each CLK pulse. The data should be clocked in on the rising edge of CLK. This applies to both the host and the QT510. The data path follows a circular buffer, with data being mutually transferred from

host to QT, and QT to host, at the same time. However the return data from the QT is always the standard response byte regardless of the command.

The setup and hold times should be observed per Figure 3-1.

3.2.4 Sleep Mode

Please refer to Figure 3-1, page 6.

The device always enters low-power sleep mode after an SPI transmission (Figure 3-1), at or before about 35µs after the last rising edge of CLK. Coincident with the sleep mode, the device will lower DRDY. If another immediate acquisition burst is desired, /SS should be raised again at least 35µs after the last rising edge of CLK. To prolong the sleep state, it is only necessary to raise /SS after an even longer duration.

Changes on CLK will also cause the device to wake, however the device will not cause an acquire burst to occur if /SS has also gone low and high again.

In sleep mode, the device consumes only a few microamps of current. The average current can be controlled by the host, by adjusting the percentage of time that the device spends in sleep.

The delay between the wake signal and the following burst is 1ms max to allow power to stabilize. If the maximum spec on /SS low (1s) is exceeded, the device will eventually come out of sleep and calibrate again on its own.

The Detect and DRDY lines will float for ~400µs (typical at Vdd = 3.3V) after wake from Sleep mode; see Section 1.3 for details.

After each acquisition burst, DRDY will rise again to indicate that the host can do another SPI transmission.

3.3 Commands

Commands are summarized in Table 3-1. Commands can be overlapped, i.e. a new command can be used to shift out the results from a prior command.

All commands cause a new acquisition burst to occur when /SS is raised again after the command byte is fully clocked.

Standard Response: All SPI shifts return a 'standard response' byte which depends on the touch detection state:

No touch detection: Bit 7 = 0 (0= not touched)
Bit 6 = 1 to indicate QWheel type
= 0 to indicate Linear slider type
Bits 5, 4, 3, 2: unused (0)
Bit 1 = 1 if signal polarity error
Bit 0 = 1 if prox detection only

Is touch detection: Bit 7 = 1 (1= is touched)
Bits 0..6: Contain calculated position

Note that touch detection calculated position is based on the results of the prior burst, which is triggered by the prior /SS rising edge (usually, from the prior command, or, from a dummy /SS trigger - see Section).

Bit 6 indicates the type of device: '1' means that the device is a wheel (e.g. QT510), and '0' means the device is a linear type (e.g. QT401).

There are 5 commands as follows.

3.3.1 0x00 - Null Command

7	6	5	4	3	2	1	0
0	0	0	0	0	0	0	0

The Null command will trigger a new acquisition (if /SS rises), otherwise, it does nothing. The response to this command is the Standard Response byte.

This command is predominant once the device has been calibrated and is running normally.

3.3.2 0x01 - Calibrate

7	6	5	4	3	2	1	0
0	0	0	0	0	0	0	1

This command takes ~525ms @ 3.3V to complete.

0x01 causes the sensor to do a basic recalibration. After the command is given the device will execute 10 acquisition bursts in a row in order to perform the recalibration, without the need for /SS to trigger each of the bursts. The host should wait for DRDY to rise again after the calibration has completed before shifting commands again.

This command should be given if there is an error flag (bit 1 of the response byte when no touch detection in progress).

On power-up the device calibrates itself automatically and so a 0x01 command is not required on startup.

The response to this command is the Standard Response byte. During calibration, device communications are suspended.

3.3.3 0x03 - Drift Compensate

7	6	5	4	3	2	1	0
0	0	0	0	0	0	1	1

0x03 causes the sensor to perform incremental drift compensation. This command must be given periodically in order to allow the sensor to compensate for drift. The more 0x03 commands issued as a percentage of all commands, the faster the drift compensation will be.

The 0x03 command must be given 10 times in order for the device to do one count of drift compensation in either direction. The 0x03 command should be used in substitution of the Null command periodically.

Example: The host causes a burst to occur by sending a 0x00 Null command every 50ms (20 per second). Every 6th command the host sends is a 0x03 (drift) command.

The maximum drift compensation slew rate in the reference level is -

$$50\text{ms} \times 6 \times 10 = 3.0 \text{ seconds}$$

The actual rate of change of the reference level depends on whether there is an offset in the signal with respect to the reference level, and whether this offset is continuous or not.

It is possible to modulate the drift compensation rate dynamically depending on circumstances, for example a significant rate of change in temperature, by varying the mix of Drift and Null commands.

If the Drift command is issued while the device is in touch detection (ie bit 7 of the Standard Response byte =1), the drift function is ignored.

Drift compensation during Free-Run mode is fixed at 6, which results in a maximum rate of drift compensation rate of about 3secs / count; see Section 1.2.

The drift compensation rate should be made slow, so that it does not interfere with finger detection. A drift compensation rate of 3s ~ 5s is suitable for almost all applications. If the setting is too fast, the device can become unnecessarily desensitized when a hand lingers near the element. Most environmental drift rates are of the order of 10's or 100's of seconds per count.

3.3.4 0x4P - Set Proximity Threshold

7	6	5	4	3	2	1	0
0	1	P ₅	P ₄	P ₃	P ₂	P ₁	P ₀

This command is optional, but if it is not given, the proximity detection function will work at a default setting of 10.

The lower 6 bits of this command (P5..P0) are used to set the proximity threshold level. Higher numbers are less sensitive (ie the signal has to travel further to cross the threshold).

Operand 'P' can range in value from 0 to 63. Zero (0) should never be used. Very low settings can cause excessive flicker in the proximity result due to low level noise and drift.

P is normally in the range from 6 to 10. The prox threshold has no hysteresis and should only be used for non-critical applications where occasional detection bounce is not a problem, like power activation (i.e. to turn on an appliance or a display).

The prox bit in the standard response and the PROX pin will both go high if the signal exceeds this threshold.

0x4P power-up default setting: 10

TABLE 3-1 - Command Summary

Hex	Command	What it does
0x00	Null	Shift out data; cause acquire burst (if /SS rises again)
0x01	Calibrate	Force recalibration of reference; causes 10 sequential bursts Power up default value = calibrated
0x03	Drift Comp	Drift compensation request; causes acquire burst. Max drift rate is 1 count per ten 0x03's.
0x4P	Prox Thresh	Set prox threshold; causes acquire burst. Bottom 6 bits ('P') are the prox threshold value. (01PP PPPP) Power up default value = 10
0x8T	Touch Thresh	Set touch threshold; causes acquire burst. Bottom 6 bits ('T') are the touch threshold value. (10TT TTTT) Power up default value = 10

3.3.5 0x8T - Set Touch Threshold

7	6	5	4	3	2	1	0
1	0	T ₅	T ₄	T ₃	T ₂	T ₁	T ₀

The lower 6 bits of this command (T5..T0) are used to set the touch threshold level. Higher numbers are less sensitive (ie the signal has to travel further to cross the threshold).

Operand 'T' can range from 0 to 63. Internally the number is multiplied by 4 to achieve a wider range. 0 should never be used.

This number is normally set to 10, more or less depending on the desired sensitivity to touch and the panel thickness. Touch detection uses a hysteresis equal to 12.5% of the threshold setting.

Both the touch bit (bit 7) in the standard response and the PROX pin will go high if this threshold is crossed. The PROX pin can be used to indicate to the host that the device has detected a finger, without the need for SPI polling. However the /SS line must remain high constantly so that the device continues to acquire continuously, or /SS has to be at least pulsed regularly (see Section) for this to work.

0x8T power-up default setting: 10

3.4 SPI - What to Send

The host should execute the following commands after powerup self-cal cycle has completed: (assuming a 50ms SPI repetition rate):

1. 0x01 - Basic calibration (optional as this is done automatically on power-up)
2. 0x4P - Set prox threshold (optional)
3. 0x8T - Set touch threshold (optional)
4. An endlessly repeating mixture of:
 - a. 0x00 (Null) - all commands except:
 - b. 0x03 (Drift compensate) - replace every nth Null command where typically, n = 6
 - c. If there is ever an error bit set, send a 0x01.

If the error occurs frequently, then perhaps the ratio of drift compensation to Nulls should be increased.

Note: the Null can be replaced by an empty /SS pulse if there is no need for fast updates.

4.1 Absolute Maximum Specifications

Operating temperature range, Ta	-40°C to +85°C
Storage temperature range, Ts	-55°C to +125°C
V _{DD}	-0.5 to +7.0V
Max continuous pin current, any control or drive pin	±20mA
Short circuit duration to ground, any pin	infinite
Short circuit duration to V _{DD} , any pin	infinite
Voltage forced onto any pin	-0.6V to (V _{DD} + 0.6) Volts

4.2 Recommended Operating Conditions

V _{DD}	+2.5 to 5.0V
Supply ripple+noise	5mV p-p max
Cs1, Cs2, Cs3	100nF
Cs1, Cs2, Cs3 relative matching	±5%
Output load, max.	±0.5mA

4.3 DC Specifications

V_{DD} = 5.0V, Cs1 = Cs2 = 100nF, 100ms rep rate, Ta = recommended range, all unless otherwise noted

Parameter	Description	Min	Typ	Max	Units	Notes
I _{DD5P}	Peak supply current		0.75	1.5	mA	@ 5V
I _{DD3P}	Peak supply current		0.45	0.6	mA	@ 3V
I _{DD5A}	Average supply current		180		µA	@ 5V
I _{DD3A}	Average supply current		110		µA	@ 3V
V _{DDS}	Supply turn-on slope	100			V/s	Required for proper startup and calibration
V _{IL}	Low input logic level			0.8	V	
V _{HIL}	High input logic level	2.2			V	
V _{OL}	Low output voltage			0.6	V	4mA sink
V _{OH}	High output voltage	V _{DD} -0.7			V	1mA source
I _{IL}	Input leakage current			±1	µA	
A _R	Acquisition resolution			7	bits	

4.4 AC Specifications

V_{DD} = 5.0V, Cs1 = Cs2 = 100nF, Ta = recommended range, unless otherwise noted

Parameter	Description	Min	Typ	Max	Units	Notes
T _R	Response time		-		ms	Under host control
S _P	Prox Sensitivity	0.15			µF	Variable parameter under host control
S _T	Touch Sensitivity	0.6			µF	Variable parameter under host control
F _{QT}	Sample frequency	92	98	104	kHz	Modulated spread-spectrum (chirp)
T _{BS}	QT Burst spacing	500			µs	
T _D	Power-up delay to operate		500		ms	
F _{SPI}	SPI clock rate	5		37	kHz	

4.5 Signal Processing and Output

Parameter	Description	Min	Typ	Max	Units	Notes
D _I	Detection integrator counts		1		counts	Both prox and touch detection
T _P	Threshold, prox	1		63		Host controlled variable
T _T	Threshold, wheel touch	1		63		Host controlled variable
H _P	Hysteresis, prox sensing		0		%	% of threshold setting
H _T	Hysteresis, touch sensing		12.5		%	% of threshold setting
D _R	Drift compensation rate			±10	%	% of bursts; host controlled
L	Position linearity		±3		%	Depends on element linearity, layout

4.6 Small Outline (SO) Package

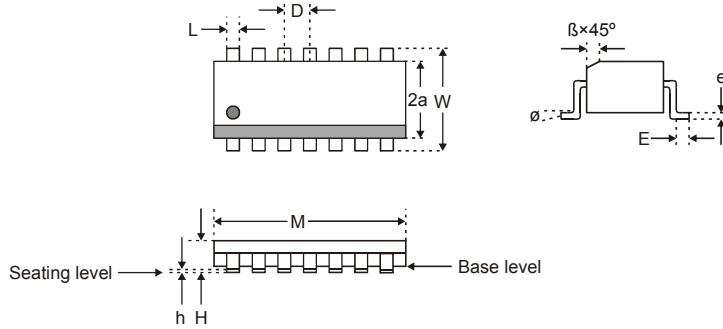

Package Type: 14 Pin SOIC						
SYMBOL	Millimeters			Inches		
	Min	Max	Notes	Min	Max	Notes
M	8.56	8.81		0.337	0.347	
W	5.79	6.20		0.228	0.244	
2a	3.81	3.99		0.150	0.157	
H	1.35	1.75		0.31	0.33	
h	0.10	0.25		0.004	0.010	
D	1.27	1.27	BSC	0.050	0.050	BSC
L	0.36	0.51		0.014	0.020	
E	0.41	1.27		0.016	0.050	
e	0.20	0.25		0.008	0.010	
B	0.25	0.51		0.014	0.020	
o	0	8		0	8	

4.7 TSSOP Package

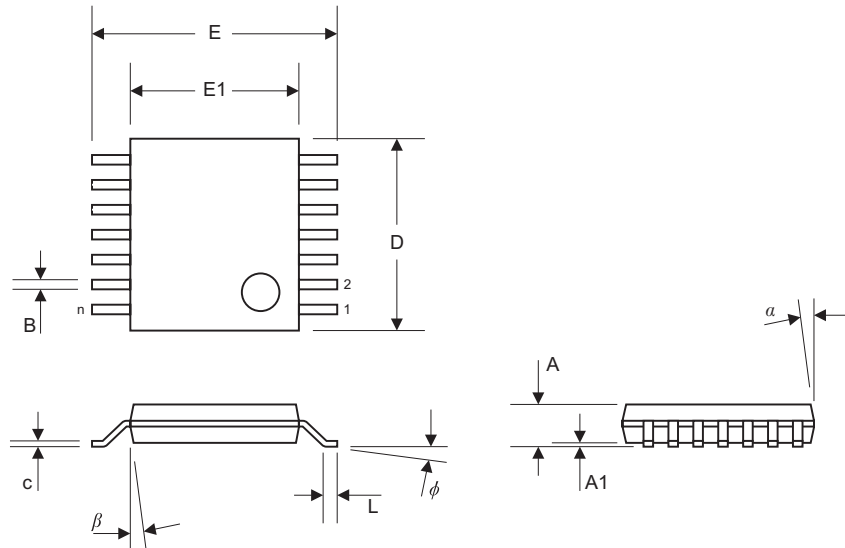

Units		INCHES			MILLIMETERS		
Dimension Limits		MIN	NOM	MAX	MIN	NOM	MAX
Number of Pins	n		14			14	
Pitch	p		0.026			0.65	
Overall Height	A			0.043			1.10
Standoff	A1	0.002	0.004	0.006	0.05	0.10	0.15
Overall Width	E	0.246	0.251	0.256	6.25	6.38	6.50
Moulded Package Width	E1	0.169	0.173	0.177	4.30	4.40	4.50
Moulded Package Length	D	0.193	0.197	0.201	4.90	5.00	5.10
Foot Length	L	0.020	0.024	0.028	0.50	0.60	0.70
Foot Angle		0	4	8	0	4	8
Lead Thickness	c	0.004	0.006	0.008	0.09	0.15	0.20
Lead Width	B	0.007	0.010	0.012	0.19	0.25	0.30
Mould Draft Angle Top	a	0	5	10	0	5	10
Mould Draft Angle Bottom		0	5	10	0	5	10

4.8 Ordering Information

PART NO.	TEMP RANGE	PACKAGE	MARKING
QT510-ISG	-40°C ~ +85°C	SO-14	QT510
QT510-ISSG	-40°C ~ +85°C	TSSOP-14	QT510

5 E510 QWheel™ Board Pictures

Figure 5.1 - E510 Eval Board (front, back)

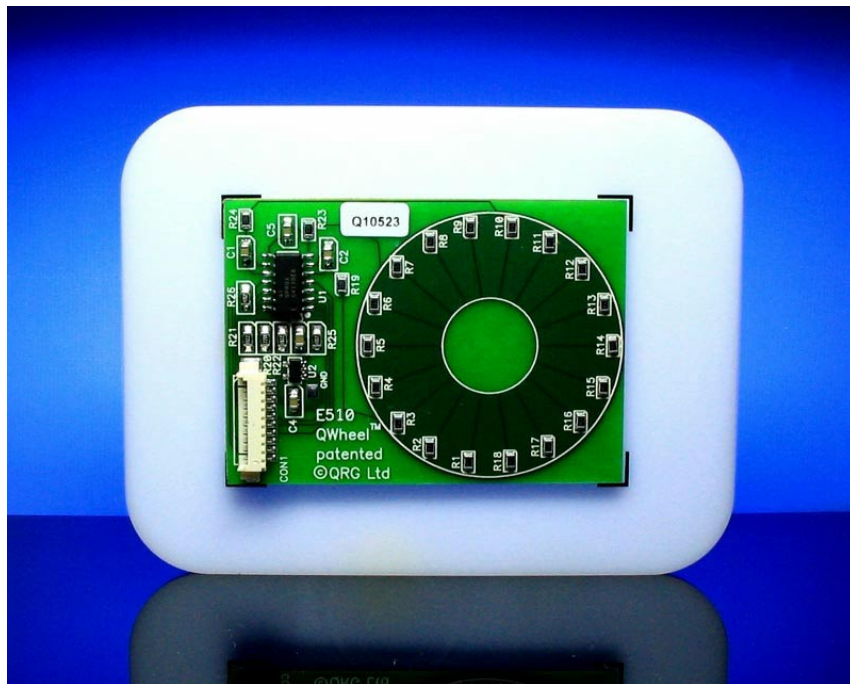



Copyright © 2004-2005 QRG Ltd. All rights reserved.
Patented and patents pending

Corporate Headquarters

1 Mitchell Point
Ensign Way, Hamble SO31 4RF
Great Britain

Tel: +44 (0)23 8056 5600 Fax: +44 (0)23 80565600

www.qprox.com

North America

651 Holiday Drive Bldg. 5 / 300
Pittsburgh, PA 15220 USA

Tel: 412-391-7367 Fax: 412-291-1015

This device covered under one or more of the following United States and international patents: 5,730,165, 6,288,707, 6,377,009, 6,452,514, 6,457,355, 6,466,036, 6,535,200. Numerous further patents are pending which may apply to this device or the applications thereof.

The specifications set out in this document are subject to change without notice. All products sold and services supplied by QRG are subject to our Terms and Conditions of sale and supply of services which are available online at www.qprox.com and are supplied with every order acknowledgment. QProx, QTouch, QMatrix, QLevel, QWheel, QView, QScreen, and QSlide are trademarks of QRG. QRG products are not suitable for medical (including lifesaving equipment), safety or mission critical applications or other similar purposes. Except as expressly set out in QRG's Terms and Conditions, no licenses to patents or other intellectual property of QRG (express or implied) are granted by QRG in connection with the sale of QRG products or provision of QRG services. QRG will not be liable for customer product design and customers are entirely responsible for their products and applications which incorporate QRG's products.

Development Team: Martin Simmons, Samuel Brunet, Luben Hristov