



Chipsmall Limited consists of a professional team with an average of over 10 year of expertise in the distribution of electronic components. Based in Hongkong, we have already established firm and mutual-benefit business relationships with customers from,Europe,America and south Asia,supplying obsolete and hard-to-find components to meet their specific needs.

With the principle of “Quality Parts,Customers Priority,Honest Operation,and Considerate Service”,our business mainly focus on the distribution of electronic components. Line cards we deal with include Microchip,ALPS,ROHM,Xilinx,Pulse,ON,Everlight and Freescale. Main products comprise IC,Modules,Potentiometer,IC Socket,Relay,Connector.Our parts cover such applications as commercial,industrial, and automotives areas.

We are looking forward to setting up business relationship with you and hope to provide you with the best service and solution. Let us make a better world for our industry!



## Contact us

Tel: +86-755-8981 8866 Fax: +86-755-8427 6832

Email & Skype: info@chipsmall.com Web: www.chipsmall.com

Address: A1208, Overseas Decoration Building, #122 Zhenhua RD., Futian, Shenzhen, China



◇ = ASO ONLY (APPLICATION SPECIFIC ORDER)

STYLE	"B"	"C"	BODY	GROUND PLANE	TERMINAL	MATED HEIGHT WITH QSE-DP-01
-01	.1680 [4.267]	.1600 [4.064]	QTE-20-01-D-XX	T-1G1-01-XXX	T-1S39-01-XXX	.197 [5.00] REF
-02	.2861 [7.267]	.2781 [7.064]	QTE-20-02-D-XX	T-1G1-02-XXX	T-1S59-02-XXX	.315 [8.00] REF
-03	.4042 [10.267]	.3962 [10.063]	QTE-20-03-D-XX	T-1G1-03-XXX	T-1S39-03-XXX	.433 [11.00] REF

No OF POS	"A"	"D"
-014	.788 [20.00]	.728 [18.48]
-028	1.575 [40.01]	1.515 [38.48]
-042	2.363 [60.01]	2.303 [58.48]
*-056	3.150 [80.01]	3.090 [78.49]
*-070	3.938 [100.01]	3.878 [98.49]

\* = SEE NOTE 15

No OF POSITIONS	COPLANARITY (INCLUDES GROUND PLANE)
-014 THRU -042	.004 [0.10]
*-056 THRU *-070	.006 [0.15]

\* = SEE NOTE 15

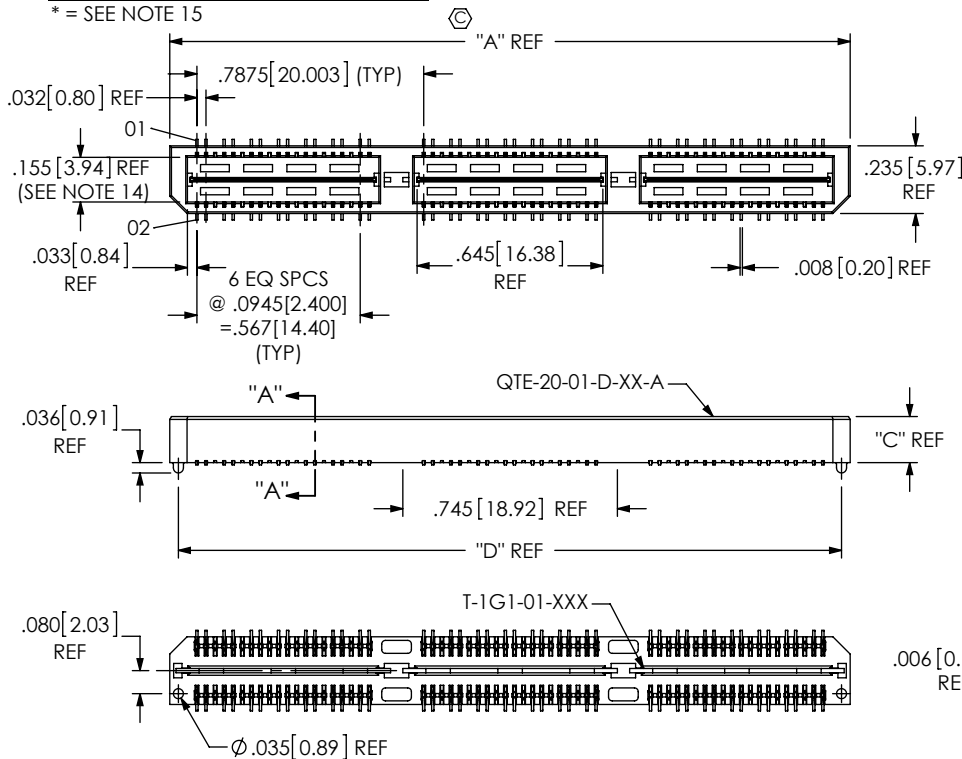

NOTES:

1. Ⓢ REPRESENTS A CRITICAL DIMENSION.
2. MINIMUM TERMINAL RETENTION: 5 OZ.
3. MINIMUM GROUND PLANE RETENTION: 1 LB
4. PARTS TO BE MOLDED TO POSITION.
5. MAXIMUM VARIANCE OF .002 [0.05]
6. DIMENSION APPLIES TO TERMINALS AND GROUND PLANE.
7. DELETED.
8. DELETED.
9. -L PLATING CAN BE SUBSTITUTED FOR -F PLATING.
10. GROUND PLANE PRESS HEIGHT MUST BE .003 [0.08] LESS THAN THE MAX HEIGHT OR .001 [0.03] GREATER THAN THE MINIMUM HEIGHT OF THE TERMINALS.
11. T-1R36 RETENTION TO BODY TO BE 1.0 LBF.
12. NOTE DELETED.
13. DUE TO THE HIGH AMOUNT OF INSERTION FORCE NEEDED, THE -LC OPTION IS NOT COMPATIBLE WITH AUTO PLACEMENT. SAMTEC RECOMMENDS MANUAL PLACEMENT FOR ALL ASSEMBLIES WITH THE -LC OPTION.
14. MAXIMUM PIN CAN EXTEND PAST WALL: .003 [0.08]
15. AVAILABLE FOR EXISTING CUSTOMERS ONLY.

FIG 1

-A: ALIGNMENT PIN OPTION (QTE-042-01-XXX-D-DP-A SHOWN) (STYLE -01, -02 & -03 ONLY)

DETAIL 'B' SCALE 6:1

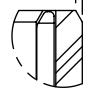

QTE-XXX-XX-XXX-D-DP-XXX

**No OF POSITIONS**  
 -014, -028, -042, \*-056, \*-070 (PER ROW) (\*SEE NOTE 15)

**LEAD STYLE**  
 -01: .1680 [4.267] (SEE FIG 1)  
 -02: .2861 [7.264] (SEE FIG 1)  
 -03: .4042 [1.123] (SEE FIG 1)  
 ◇ -04: .600 [15.24] (SEE FIG 4, SHT 3)  
 ◇ -05: .718 [18.237] (SEE FIG 4, SHT 3)  
 ◇ -06: .835 [21.209] (SEE FIG 4, SHT 3)  
 ◇ -07: .954 [24.232] (SEE FIG 4, SHT 3)  
 ◇ -08: 1.151 [29.24] (SEE FIG 4, SHT 3)  
 ◇ -09: .522 [13.258] (SEE FIG 4, SHT 3)  
 ◇ -10: .5606 [14.239] (SEE FIG 4, SHT 3)

**PLATING SPECIFICATION**  
 -F: 3μ" FLASH GOLD IN CONTACT AREA, MATTE TIN ON TAIL (USE T-1SXX-XX-F, T-1G1-XX-F) (SEE NOTE 9)  
 -L: 10μ" LIGHT GOLD IN CONTACT AREA, MATTE TIN ON TAIL (USE T-1SXX-XX-L, T-1G1-XX-L)  
 -H: 30μ" HEAVY GOLD IN CONTACT AREA, 3μ" GOLD ON TAIL (USE T-1SXX-XX-H, T-1G1-XX-G)  
 -C: 50μ" ELECTRO-POLISHED SELECTIVE IN CONTACT AREA, MATTE TIN ON TAIL (USE T-1SXX-XX-C, T-1G1-XX-L)  
 -STL: 30μ" HEAVY SELECTIVE GOLD IN CONTACT AREA, TIN LEAD ON TAIL (USE T-1SXX-XX-STL, T-1G1-XX-STL)  
 -FTL: 3μ" FLASH SELECTIVE GOLD IN CONTACT AREA, TIN LEAD ON TAIL (USE T-1SXX-XX-FTL, T-1G1-XX-FTL)

**OPTION**  
 -A: ALIGNMENT PINS  
 -LC: LOCKING CLIPS (SEE NOTE 13) (USE LC-08-TM-01) (SEE FIG 2, SHT 2)  
 -K: POLYIMIDE FILM (USE K-DOT-276-.375-.005) (SEE FIG 3, SHT 2) (N/A ON STYLES -07 & -08)  
 -GP: GUIDE POSTS (AVAILABLE ON -01 ONLY) (USE QTE-20-01-D-XX-X-GP) (SEE FIG 4, SHT 3)  
 -TR: TAPE & REEL (42 POS. MAX) (NOT AVAILABLE ON -05, -06, -07, -08 LEAD STYLES) (028 POS MAX FOR -GP OPTION)  
 -RT1: RETENTION OPTION (SEE FIG 9, SHT 5) (ONLY AVAILABLE ON -01 LEAD STYLE) (MUST USE -A OPTION) (NOT AVAILABLE WITH -LC, -GP, OR -L) (NOT AVAILABLE ON -056 & -070 POS)  
 -L: LATCHING OPTION (28 POS. MAX.) (SEE FIG 10, SHT 5) (MUST USE -A OPTION) (AVAILABLE ON -01 ONLY) (NOT AVAILABLE WITH -LC, -GP, OR -RT1)

**BODY STYLE**  
 -DP: DIFFERENTIAL PAIRS

**ROW SPECIFICATION**  
 -D: DOUBLE (USE QTE-20-XX-D-XX & QTEH-20-XX-D-XX)

No OF BANKS

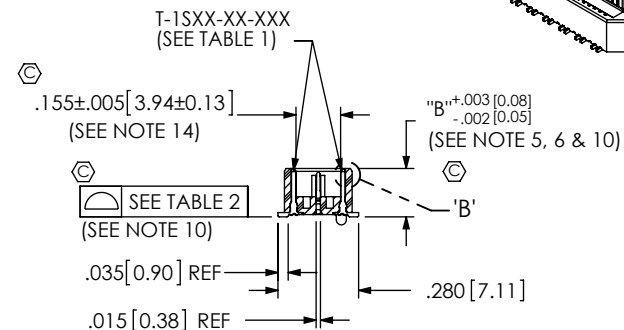
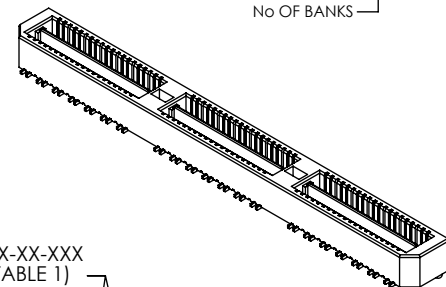

UNLESS OTHERWISE SPECIFIED, DIMENSIONS ARE IN INCHES. TOLERANCES ARE: DECIMALS ANGLES .XX: ±.01 [3] .XXX: ±.005 [13] .XXXX: ±.0020 [051]	PROPRIETARY NOTE THIS DOCUMENT CONTAINS CONFIDENTIAL AND PROPRIETARY INFORMATION AND ALL DESIGN, MANUFACTURING, REPRODUCTION, USE, PATENT RIGHTS AND SALES RIGHTS ARE EXPRESSLY RESERVED BY SAMTEC, INC. THIS DOCUMENT SHALL NOT BE DISCLOSED, IN WHOLE OR PART, TO ANY UNAUTHORIZED PERSON OR ENTITY NOR REPRODUCED, TRANSFERRED OR INCORPORATED IN ANY OTHER PROJECT IN ANY MANNER WITHOUT THE EXPRESS WRITTEN CONSENT OF SAMTEC, INC.	<b>samtec</b> 520 PARK EAST BLVD. NEW ALBANY, IN 47150 PHONE: 812-944-6733 FAX: 812-948-5047 e-Mail info@SAMTEC.com code 55322
MATERIAL: DO NOT SCALE DRAWING	SHEET SCALE: 1.5:1	DESCRIPTION: .8mm DIFFERENTIAL PAIRS HS TERMINAL ASSEMBLY
INSULATOR: LCP, UL94V-0; COLOR: BLACK TERMINAL: PHOS BRONZE GROUND PLANE: PHOS BRONZE		DWG. NO. QTE-XXX-XX-XXX-D-DP-XXX
F:\DWG\MISC\MKTG\QTE-XXX-XX-XXX-D-DP-XXX-MKT.SLDDRW		BY: DEAN P 4/28/2000 SHEET 1 OF 5

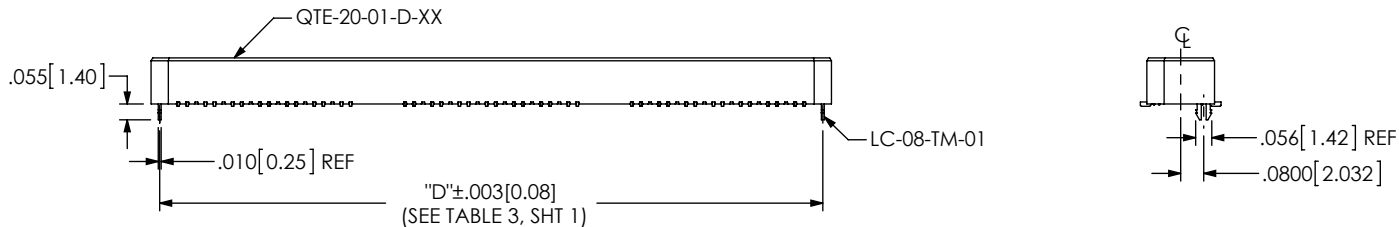

FIG 2  
 -LC: LOCKING CLIP OPTION  
 (QTS-042-01-XXX-D-DP-LC SHOWN)  
 (DIFFERENT AS SHOWN, OTHERWISE SAME AS FIG 1)

No OF POS	"R"				"S"			
	-LC, -A, -FL	-GP, -SD	-RT1	-L	-LC, -A, -FL	-GP, -SD	-RT1	-L
-014	.788 [20.00]	1.305 [33.15]	1.438 [36.53]	.906 [23.00]	.256 [6.50]	.515 [13.07]	.581 [14.76]	.315 [7.99]
-028	1.575 [40.01]	2.093 [53.15]	2.226 [56.53]	1.693 [43.00]	.650 [16.50]	.908 [23.07]	.975 [24.76]	.709 [18.00]
-042	2.363 [60.01]	2.880 [73.15]	3.013 [76.53]	N/A	1.043 [26.50]	1.302 [33.07]	1.369 [34.76]	N/A
*-056	3.150 [80.01]	3.668 [93.15]	N/A	N/A	1.437 [36.50]	1.696 [43.07]	N/A	N/A
*-070	3.938 [100.01]	4.455 [113.16]	N/A	N/A	1.831 [46.50]	2.090 [53.07]	N/A	N/A

STYLE	"T"
-01	.173[4.39]
-02	.291[7.39]
-03	.409[10.39]
-04	.605[15.37]
-05	.723[18.36]
-06	.841[21.36]
-09	.527[13.39]
-10	.567[14.37]

\* = SEE NOTE 15

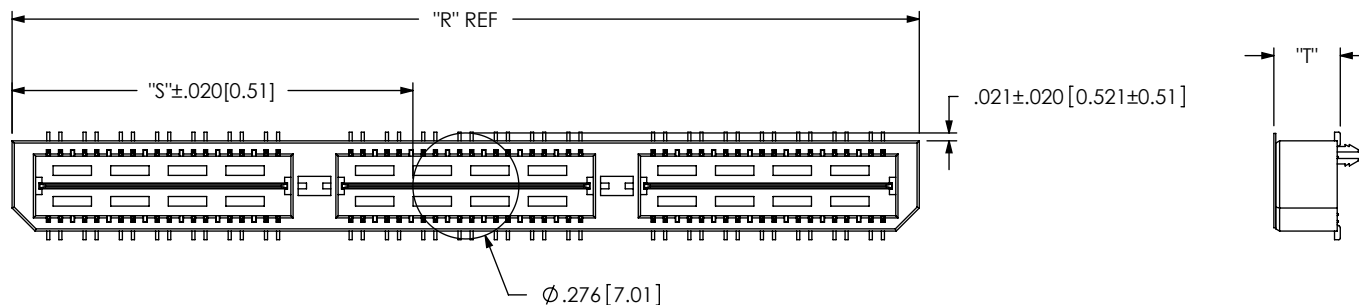



FIG 3  
 -K: POLYIMIDE FILM PAD  
 (USE K-DOT-.276-.375-.005)

DO NOT SCALE DRAWING  SHEET SCALE: 2:1	* PROPRIETARY NOTE * THIS DOCUMENT CONTAINS CONFIDENTIAL AND PROPRIETARY INFORMATION AND ALL DESIGN, MANUFACTURING, REPRODUCTION, USE, PATENT RIGHTS AND SALES RIGHTS ARE EXPRESSLY RESERVED BY SAMTEC, INC. THIS DOCUMENT SHALL NOT BE DISCLOSED, IN WHOLE OR PART, TO ANY UNAUTHORIZED PERSON OR ENTITY NOR REPRODUCED, TRANSFERRED OR INCORPORATED IN ANY OTHER PROJECT IN ANY MANNER WITHOUT THE EXPRESS WRITTEN CONSENT OF SAMTEC, INC.	 520 PARK EAST BLVD, NEW ALBANY, IN 47150 PHONE: 812-944-6733 FAX: 812-948-5047 e-Mail info@SAMTEC.com code 55322
	DESCRIPTION: .8mm DIFFERENTIAL PAIRS HS TERMINAL ASSEMBLY	
	DWG. NO. <b>QTE-XXX-XX-XXX-D-DP-XXX</b>	
BY: DEAN P 4/28/2000	SHEET 2 OF 5	

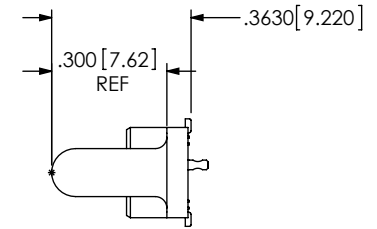
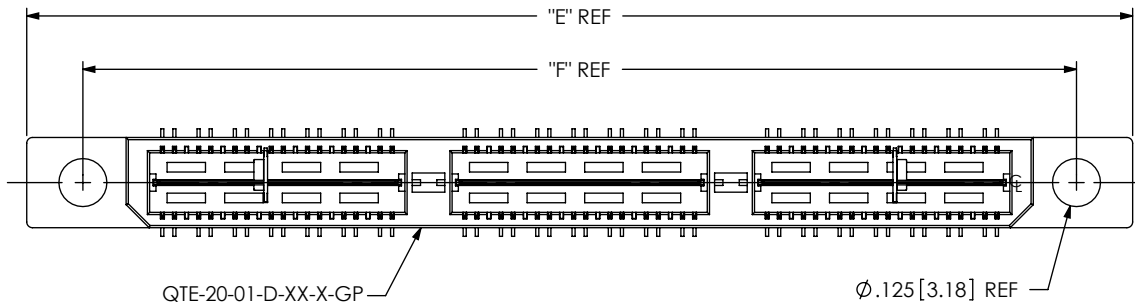

FIG 4  
 -GP: GUIDE POST OPTION  
 (QTE-042-01-XXX-D-DP-GP SHOWN)  
 (DIFFERENT AS SHOWN, OTHERWISE SAME AS FIG 1)  
 (AVAILABLE ON STYLE -01 ONLY)

POS	"E"	"F"
-014	1.305 [33.15]	1.013 [25.72]
-028	2.093 [53.15]	1.800 [45.72]
-042	2.880 [73.15]	2.588 [65.72]
*-056	3.668 [93.15]	3.375 [85.73]
*-070	4.455 [113.16]	4.163 [105.73]

\* = SEE NOTE 15

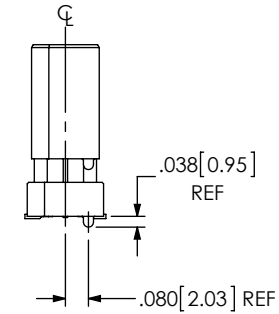
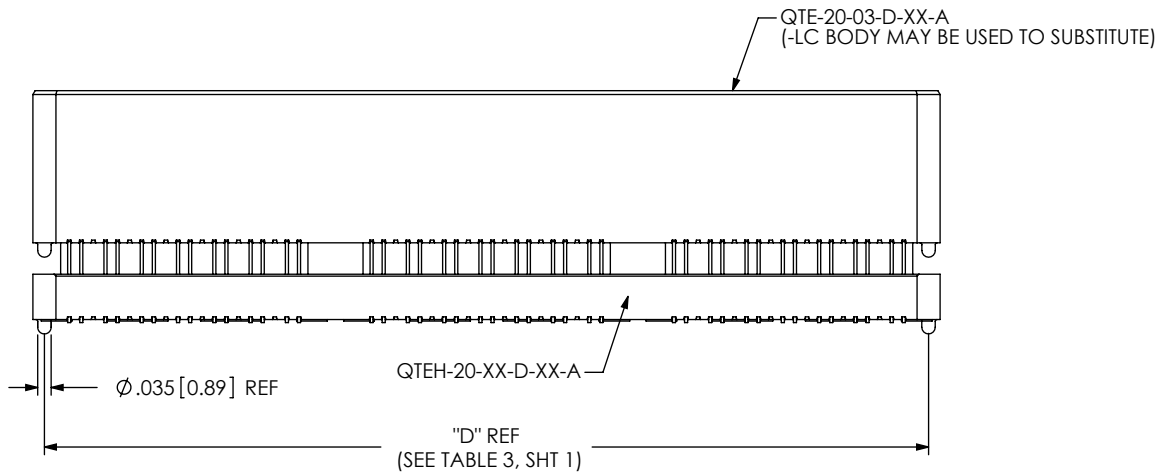

FIG 5  
 (QTE-020-04-XXX-D-A SHOWN)  
 (DIFFERENT AS SHOWN, OTHERWISE SAME AS FIG 1)  
 (STYLES -04, -05, -06, -07, -08, -09 & -10, SEE TABLE 7, SHT 4)

DO NOT SCALE DRAWING  SHEET SCALE: 2:1	* PROPRIETARY NOTE THIS DOCUMENT CONTAINS CONFIDENTIAL AND PROPRIETARY INFORMATION AND ALL DESIGN, MANUFACTURING, REPRODUCTION, USE, PATENT RIGHTS AND SALES RIGHTS ARE EXPRESSLY RESERVED BY SAMTEC, INC. THIS DOCUMENT SHALL NOT BE DISCLOSED, IN WHOLE OR PART, TO ANY UNAUTHORIZED PERSON OR ENTITY NOR REPRODUCED, TRANSFERRED OR INCORPORATED IN ANY OTHER PROJECT IN ANY MANNER WITHOUT THE EXPRESS WRITTEN CONSENT OF SAMTEC, INC.	 520 PARK EAST BLVD, NEW ALBANY, IN 47150 PHONE: 812-944-6733 FAX: 812-948-5047 e-Mail info@SAMTEC.com code 55322
	DESCRIPTION: .8mm DIFFERENTIAL PAIRS HS TERMINAL ASSEMBLY	
	DWG. NO. QTE-XXX-XX-XXX-D-DP-XXX	
	BY: DEAN P 4/28/2000	SHEET 3 OF 5

TABLE 7						MATED HEIGHT WITH QSE-DP-01
STYLE	"B"	GROUND PLANE	TERMINAL	FILLER BODY	SPACER BODY	
-04	.600[15.24]	T-1G1-04-XXX	T-1S41-04-XXX	QTE-20-03-D-XX	QTEH-20-01-D-XX-X	.630 [16.00] REF
-05	.718[18.237]	T-1G1-05-XXX	T-1S41-05-XXX	QTE-20-03-D-XX	QTEH-20-01-D-XX-X	.748 [19.00] REF
-06	.835[21.209]	T-1G1-06-XXX	T-1S41-06-XXX	QTE-20-03-D-XX	QTEH-20-02-D-XX-X	.866 [22.00] REF
-07	.954[24.232]	T-1G17-01-XXX	T-1S61-21-XXX	QTEH-20-04-D-XX-X	QTE-20-02-D-XX-X	.984 [25.00] REF
-08	1.151[29.24]	T-1G17-02-XXX	T-1S61-22-XXX	QTEH-20-04-D-XX-X	QTE-20-02-D-XX-X	1.181 [30.00] REF
-09	.522[13.259]	T-1G1-09-XXX	T-1S60-09-XXX	QTEH-20-01-D-XX-X	QTE-20-02-D-XX-X	.551[14.00] REF
-10	.5606[14.239]	T-1G1-10-XXX	T-1S60-10-XXX	QTEH-20-01-D-XX-X	QTE-20-02-D-XX-X	.591[15.00] REF

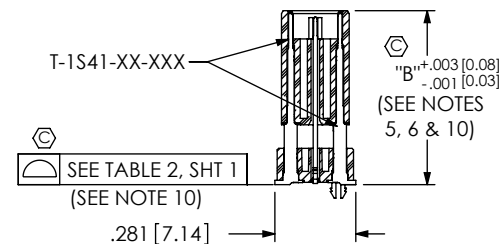
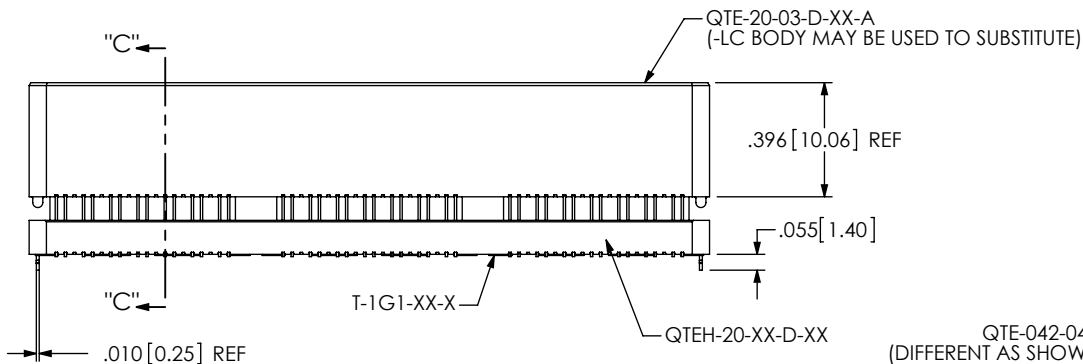
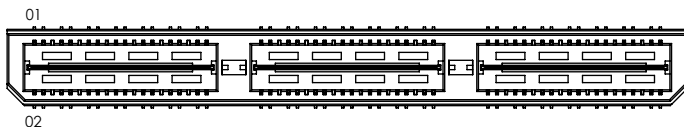

FIG 6  
QTE-042-04-X-D-DP-LC SHOWN  
(DIFFERENT AS SHOWN, OTHERWISE SAME AS FIG 1)  
(STYLES -04, -05 & -06)

SECTION "C"-"C"

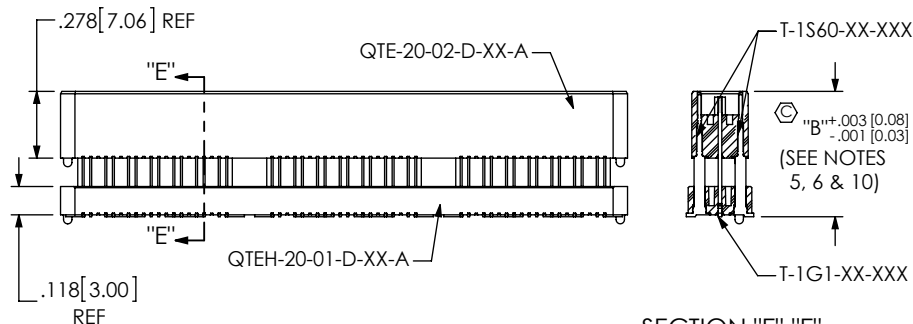
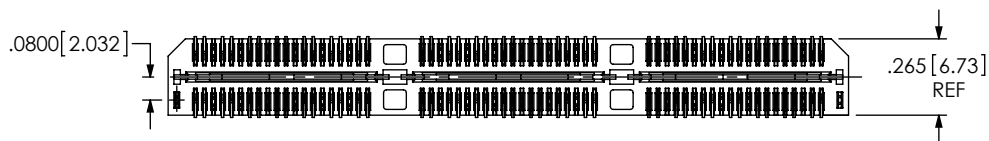
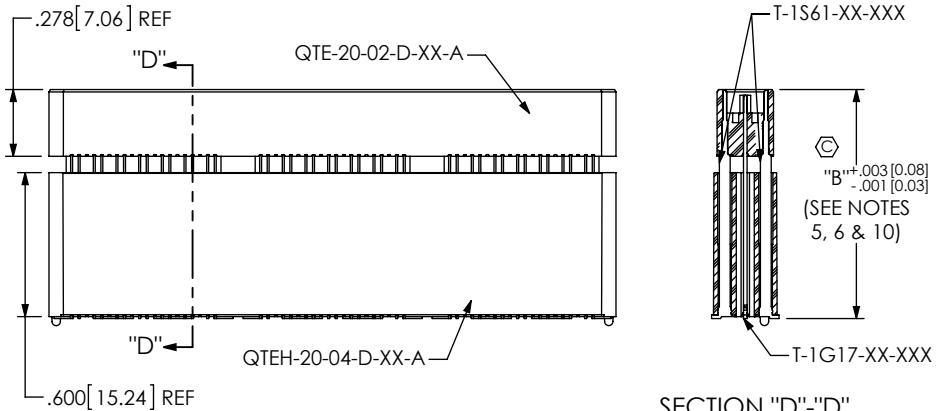

FIG 8  
QTE-042-09-X-D-DP-A SHOWN  
(DIFFERENT AS SHOWN, OTHERWISE SAME AS FIG 6)  
(STYLES -09 & -10)

SECTION "E"-"E"  
SCALE 1.25 : 1



SECTION "D"-"D"  
SCALE 1.25 : 1

FIG 7  
QTE-042-07-X-D-DP-A SHOWN  
(DIFFERENT AS SHOWN, OTHERWISE SAME AS FIG 6)  
(STYLES -07 & -08)

F:\DWG\MISC\MKTG\QTE-XXX-XX-XXX-D-DP-XXX-MKT.SLDDRW

**PROPRIETARY NOTE**  
THIS DOCUMENT CONTAINS CONFIDENTIAL AND PROPRIETARY INFORMATION AND ALL DESIGN, MANUFACTURING, REPRODUCTION, USE, PATENT RIGHTS AND SALES RIGHTS ARE EXPRESSLY RESERVED BY SAMTEC, INC. THIS DOCUMENT SHALL NOT BE DISCLOSED, IN WHOLE OR PART, TO ANY UNAUTHORIZED PERSON OR ENTITY NOR REPRODUCED, TRANSFERRED OR INCORPORATED IN ANY OTHER PROJECT IN ANY MANNER WITHOUT THE EXPRESS WRITTEN CONSENT OF SAMTEC, INC.



520 PARK EAST BLVD, NEW ALBANY, IN 47150  
PHONE: 812-944-6733 FAX: 812-948-5047  
e-Mail: info@SAMTEC.com code 55322

DO NOT SCALE DRAWING

SHEET SCALE: 1.5:1

DESCRIPTION:  
.8mm DIFFERENTIAL PAIRS HS TERMINAL ASSEMBLY

DWG. NO.  
**QTE-XXX-XX-XXX-D-DP-XXX**

BY: DEAN P 4/28/2000 SHEET 4 OF 5

TABLE 8		
POS	"G"	"H"
-014	1.438 [36.53]	1.129 [28.68]
-028	2.226 [56.53]	1.917 [48.68]
-042	3.013 [76.53]	2.704 [68.68]
*-056	N/A	N/A
*-070	N/A	N/A

\* = SEE NOTE 15

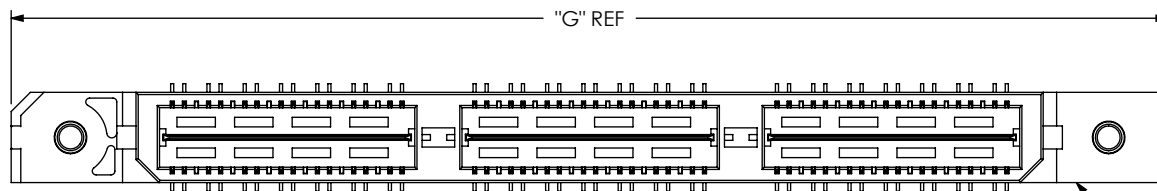

QTE-20-01-D-XX-A-RT1

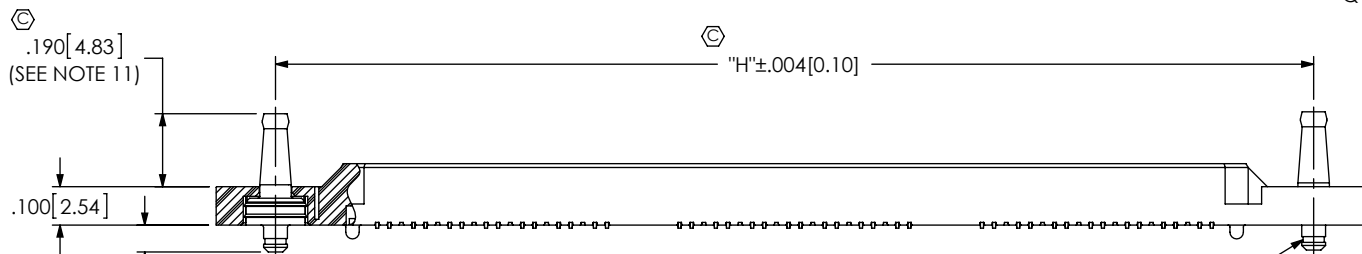

T-1R36-01-F (2 PLCS)

**FIG 9**  
 -RT1: RETENTION OPTION  
 (QTE-042-01-XXX-D-DP-A-RT1 SHOWN)  
 (DIFFERENT AS SHOWN, OTHERWISE SAME AS FIG 1)  
 (ONLY AVAILABLE ON -01 LEAD STYLE) (MUST USE -A OPTION)  
 (NOT AVAILABLE WITH -LC, -GP, OR -L OPTIONS)  
 (NOT AVAILABLE ON \*-056 & \*-070 POSITIONS)  
 \* = SEE NOTES 12 & 15

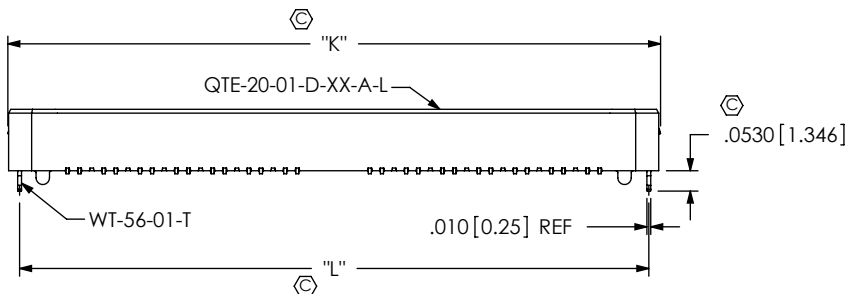
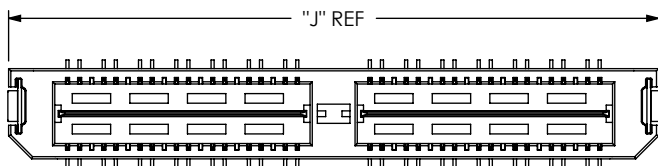

**FIG 10**  
 -L: LATCHING OPTION  
 (QTE-028-01-XXX-D-DP-A-L SHOWN)  
 (DIFFERENT AS SHOWN, OTHERWISE SAME AS FIG 1)  
 (28 POS MAX) (MUST USE -A OPTION)  
 (AVAILABLE ON -01 LEAD STYLE ONLY)  
 (NOT AVAILABLE WITH -LC, -GP, OR -RT1)

TABLE 9			
POS	"J"	"K"	"L"
-014	.906 [23.00]	.915 [23.24]	.854 [21.69]
-028	1.693 [43.00]	1.703 [43.24]	1.642 [41.69]
-042	N/A	N/A	N/A
*-056	N/A	N/A	N/A
*-070	N/A	N/A	N/A

\* = SEE NOTE 15

CRITICAL DIMENSION INSPECTION INSTRUCTION TABLE	
ASSEMBLY OPERATION	IN PROCESS INSPECTION
FILL T-1SXX	C1, C2, C3, C4, C5, C11, C12
FILL GROUND PLANE T-1G1	C4
ADD -LC OPTION	C13
ADD -RT1 OPTION	C6, C7
ADD -L OPTION	C8, C9, C10
ADD -K OPTION	C14, C15

**PROPRIETARY NOTE**

THIS DOCUMENT CONTAINS CONFIDENTIAL AND PROPRIETARY INFORMATION AND ALL DESIGN, MANUFACTURING, REPRODUCTION, USE, PATENT RIGHTS AND SALES RIGHTS ARE EXPRESSLY RESERVED BY SAMTEC, INC. THIS DOCUMENT SHALL NOT BE DISCLOSED, IN WHOLE OR PART, TO ANY UNAUTHORIZED PERSON OR ENTITY NOR REPRODUCED, TRANSFERRED OR INCORPORATED IN ANY OTHER PROJECT IN ANY MANNER WITHOUT THE EXPRESS WRITTEN CONSENT OF SAMTEC, INC.



520 PARK EAST BLVD, NEW ALBANY, IN 47150  
 PHONE: 812-944-6733 FAX: 812-948-5047  
 e-Mail: info@SAMTEC.com code 55322

DO NOT SCALE DRAWING

SHEET SCALE: 2:1

DESCRIPTION:  
 .8mm DIFFERENTIAL PAIRS HS TERMINAL ASSEMBLY

DWG. NO.  
**QTE-XXX-XX-XXX-D-DP-XXX**

BY: DEAN P 4/28/2000 SHEET 5 OF 5