



Chipsmall Limited consists of a professional team with an average of over 10 year of expertise in the distribution of electronic components. Based in Hongkong, we have already established firm and mutual-benefit business relationships with customers from,Europe,America and south Asia,supplying obsolete and hard-to-find components to meet their specific needs.

With the principle of “Quality Parts,Customers Priority,Honest Operation,and Considerate Service”,our business mainly focus on the distribution of electronic components. Line cards we deal with include Microchip,ALPS,ROHM,Xilinx,Pulse,ON,Everlight and Freescale. Main products comprise IC,Modules,Potentiometer,IC Socket,Relay,Connector.Our parts cover such applications as commercial,industrial, and automotives areas.

We are looking forward to setting up business relationship with you and hope to provide you with the best service and solution. Let us make a better world for our industry!



Contact us

Tel: +86-755-8981 8866 Fax: +86-755-8427 6832

Email & Skype: info@chipsmall.com Web: www.chipsmall.com

Address: A1208, Overseas Decoration Building, #122 Zhenhua RD., Futian, Shenzhen, China



PACKAGE DIMENSIONS

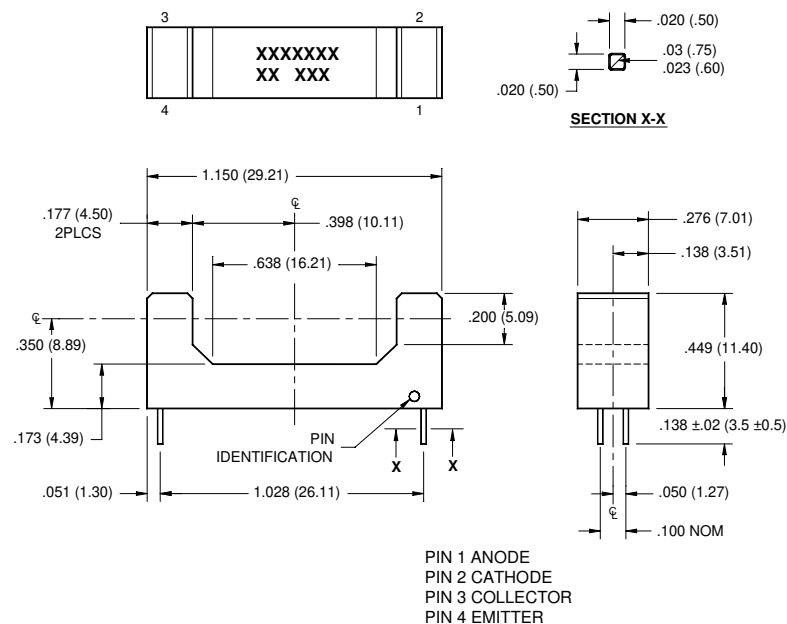

NOTES:

1. Dimensions for all drawings are in inches (mm).
2. Tolerance of $\pm .010$ (.25) on all non-nominal dimensions unless otherwise specified.

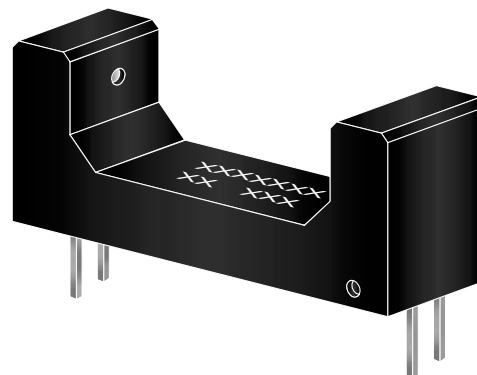

SCHEMATIC

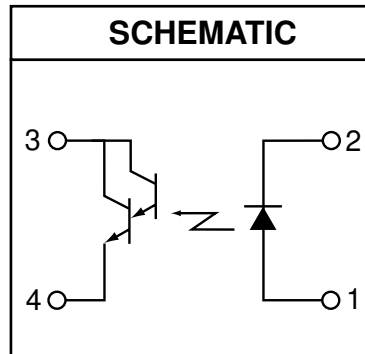

DESCRIPTION

The QVL25335 consists of an infrared light emitting diode coupled to an NPN silicon photodarlington packaged into an injection molded housing.

FEATURES

- 20 mm wide gap
- PC Board mount
- .060" apertures
- Sensor filter to attenuate visible light
- High CTR

ABSOLUTE MAXIMUM RATINGS ($T_A = 25^\circ\text{C}$ unless otherwise specified)			
Parameter	Symbol	Rating	Unit
Operating Temperature	T_{OPR}	-40 to +85	$^\circ\text{C}$
Storage Temperature	T_{STG}	-40 to +85	$^\circ\text{C}$
Soldering Temperature (Iron) ^(2,3 and 4)	$T_{\text{SOL-I}}$	240 for 5 sec	$^\circ\text{C}$
Soldering Temperature (Flow) ^(2 and 3)	$T_{\text{SOL-F}}$	260 for 10 sec	$^\circ\text{C}$
INPUT (EMITTER)			
Continuous Forward Current	I_F	50	mA
Reverse Voltage	V_R	6	V
Power Dissipation ⁽¹⁾	P_D	100	mW
OUTPUT (SENSOR)			
Collector to Emitter Voltage	V_{CEO}	30	V
Emitter to Collector Voltage	V_{ECO}	6	V
Collector Current	I_C	40	mA
Power Dissipation ⁽¹⁾	P_D	150	mW

NOTES:

1. Derate power dissipation linearly 1.67 mW/ $^\circ\text{C}$ above 25 $^\circ\text{C}$.
2. RMA flux is recommended.
3. Methanol or isopropanol alcohols are recommended as cleaning agents.
4. Soldering iron tip 1/16" (1.6 mm) minimum from housing.

ELECTRICAL / OPTICAL CHARACTERISTICS ($T_A = 25^\circ\text{C}$)						
PARAMETER	TEST CONDITIONS	SYMBOL	MIN	TYP	MAX	UNITS
INPUT (EMITTER)						
Forward Voltage	$I_F = 20 \text{ mA}$	V_F	—	—	1.7	V
Reverse Leakage Current	$V_R = 5 \text{ V}$	I_R	—	—	100	μA
OUTPUT (SENSOR)						
Emitter to Collector Breakdown	$I_E = 100 \mu\text{A}$	BV_{ECO}	6	—	—	V
Collector to Emitter Breakdown	$I_C = 1 \text{ mA}$	BV_{CEO}	30	—	—	V
Collector to Emitter Leakage	$V_{\text{CE}} = 10 \text{ V}$	I_{CEO}	—	—	100	nA
COUPLED						
On-State Collector Current	$I_F = 10 \text{ mA}, V_{\text{CE}} = 5 \text{ V}$	$I_{\text{C(ON)}}$	5.0	—	—	mA
Saturation Voltage	$I_F = 10 \text{ mA}, I_C = 2 \text{ mA}$	$V_{\text{CE(SAT)}}$	—	—	1.0	V

DISCLAIMER

FAIRCHILD SEMICONDUCTOR RESERVES THE RIGHT TO MAKE CHANGES WITHOUT FURTHER NOTICE TO ANY PRODUCTS HEREIN TO IMPROVE RELIABILITY, FUNCTION OR DESIGN. FAIRCHILD DOES NOT ASSUME ANY LIABILITY ARISING OUT OF THE APPLICATION OR USE OF ANY PRODUCT OR CIRCUIT DESCRIBED HEREIN; NEITHER DOES IT CONVEY ANY LICENSE UNDER ITS PATENT RIGHTS, NOR THE RIGHTS OF OTHERS.

LIFE SUPPORT POLICY

FAIRCHILD'S PRODUCTS ARE NOT AUTHORIZED FOR USE AS CRITICAL COMPONENTS IN LIFE SUPPORT DEVICES OR SYSTEMS WITHOUT THE EXPRESS WRITTEN APPROVAL OF THE PRESIDENT OF FAIRCHILD SEMICONDUCTOR CORPORATION. As used herein:

1. Life support devices or systems are devices or systems which, (a) are intended for surgical implant into the body, or (b) support or sustain life, and (c) whose failure to perform when properly used in accordance with instructions for use provided in labeling, can be reasonably expected to result in a significant injury of the user.
2. A critical component in any component of a life support device or system whose failure to perform can be reasonably expected to cause the failure of the life support device or system, or to affect its safety or effectiveness.