



Chipsmall Limited consists of a professional team with an average of over 10 year of expertise in the distribution of electronic components. Based in Hongkong, we have already established firm and mutual-benefit business relationships with customers from,Europe,America and south Asia,supplying obsolete and hard-to-find components to meet their specific needs.

With the principle of "Quality Parts,Customers Priority,Honest Operation,and Considerate Service",our business mainly focus on the distribution of electronic components. Line cards we deal with include Microchip,ALPS,ROHM,Xilinx,Pulse,ON,Everlight and Freescale. Main products comprise IC,Modules,Potentiometer,IC Socket,Relay,Connector.Our parts cover such applications as commercial,industrial, and automotives areas.

We are looking forward to setting up business relationship with you and hope to provide you with the best service and solution. Let us make a better world for our industry!



Contact us

Tel: +86-755-8981 8866 Fax: +86-755-8427 6832

Email & Skype: info@chipsmall.com Web: www.chipsmall.com

Address: A1208, Overseas Decoration Building, #122 Zhenhua RD., Futian, Shenzhen, China



Features

Switching Regulator

- Efficiency up to 93%, no need for heatsinks
- High voltage input range, up to 50V
- Short Circuit Protection, Thermal Shutdown
- All-in-one solution, no external components required
- IEC/EN60950-1 + AM:2 Certified

Description

The R-78HBxx/W-Series high efficiency, high input voltage switching regulators are ideally suited to replace 78xx linear regulators. The efficiency of up to 93% means that very little energy is wasted as heat so there is no need for any heat sinks with their additional space and mounting costs. A wide input voltage range allows the full stored energy utilization of standard 12, 24 and 36V batteries as well as COB LED drivers. No external components are required to make a complete regulated, short-circuit protected supply. A built-in protection diode allows high capacitive loads. Typical applications include Auxiliary fan CV power supplies powered from CC LED drivers, industrial, aerospace and battery powered applications.

Selection Guide

Part Number	Input Voltage Range ⁽²⁾ [VDC]	Output Voltage [VDC]	Output Current [A]	Efficiency typ @ min Vin. [%]	Max. Capacitive Load ⁽¹⁾ [μF]
R-78HB5.0-0.5/W	9-72	5.0	0.5	86	100/6800
R-78HB12-0.5/W	17-72	12	0.5	93	100/6800

Notes:

Note1: with normal start-up time and no external components = 100μF
with <1S start-up time = 6800μF

Specifications (measured @ ta= 25°C, full load, nominal input voltage and after warm-up)

BASIC CHARACTERISTICS					
Parameter	Condition	Min.	Typ.	Max.	
Input Voltage Range ⁽²⁾	5Vout 12Vout	9VDC 17VDC	48VDC 48VDC	72VDC 72VDC	
Short Circuit Input Current			15mA	25mA	
Quiescent Current	Vin = 48VDC, 10% load	1mA		5mA	
Internal Power Dissipation			0.65W		
Internal Operating Frequency	full load	120kHz		800kHz	
Efficiency				see Selection Guide	
Minimum Load ⁽³⁾		10mA			
Output Ripple and Noise			20mVp-p	60mVp-p	

Typical Application Circuit

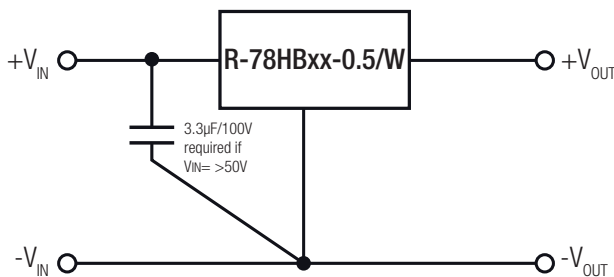

Notes:

Note2: The converter has built in soft start circuit. Rapidly changing the input voltage from VINmin to VINmax can bypass this circuit and damage the converter.

Note3: Operation under no load will not damage the devices, however they may not meet all specifications. A minimum load of 10mA is recommended.

continued on next page

R-78HB/W

0.5 AMP SIP3 Wired Single Output



IEC60950-1 Certified
EN60950-1 Certified
EN55022 Certified

Specifications (measured @ $t_a = 25^\circ\text{C}$, full load, nominal input voltage and after warm-up)

Efficiency vs. Load

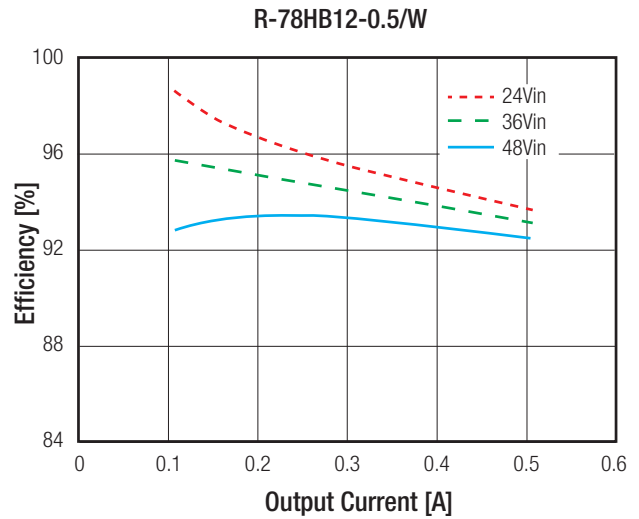
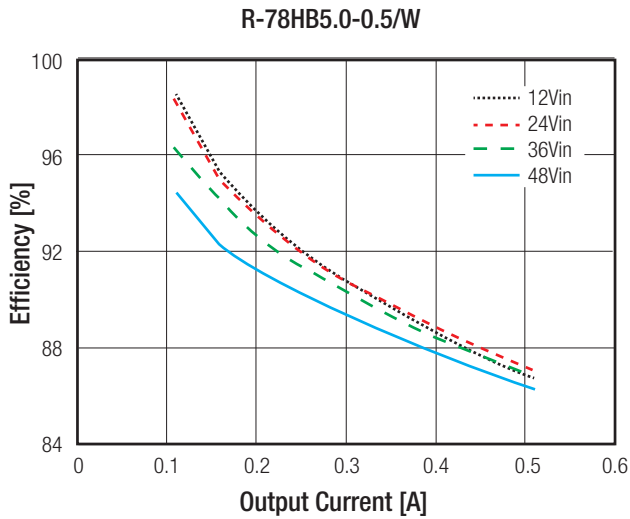

REGULATIONS

Parameter	Condition	Value
Output Voltage Accuracy	100% load	$\pm 2\%$ typ. / $\pm 3\%$ max.
Line Voltage Regulation	$V_{in} = \text{min. to max.}$, full load	0.4% typ. / 1% max.
Load Voltage Regulation	10% to 100% load	0.3% typ. / 0.6% max.
Dynamic Load Stability	with 100 μF output Capacitor, 100% \leftrightarrow 50% load	$\pm 75\text{mV}$ typ. / $\pm 100\text{mV}$ max.

PROTECTIONS

Parameter	Condition	Value
Internal Input Filter		1 μF Capacitor
Short Circuit Protection (SCP)		continuous, automatic recovery

Optional Protection Circuit

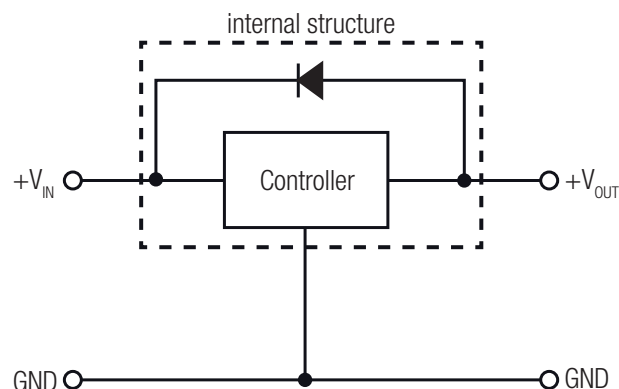

Specifications (measured @ $t_a = 25^\circ\text{C}$, full load, nominal input voltage and after warm-up)

ENVIRONMENTAL

Parameter	Condition	Value
Operating Temperature Range	with derating (see graph)	-40°C to $+85^\circ\text{C}$
Maximum Case Temperature		$+100^\circ\text{C}$
Case Thermal Impedance		55°C/W
MTBF	MIL-HDBK 217F, $+25^\circ\text{C}$	7395×10^3 hours
	MIL-HDBK 217F, $+71^\circ\text{C}$	1242×10^3 hours

Derating Graph

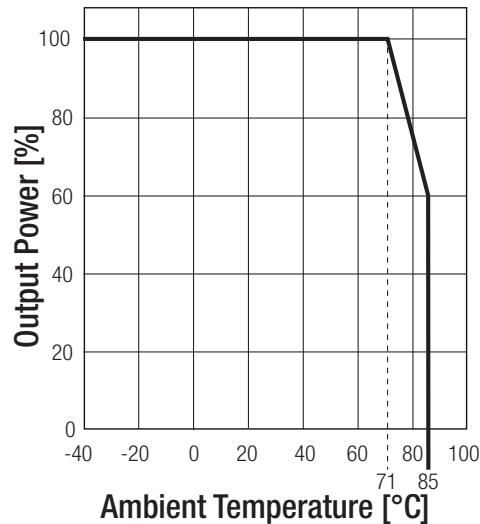

SAFETY AND CERTIFICATIONS

Certificate Type	Report / File Number	Standard
IEC/EN General Safety	LVD 1603123	IEC/EN-60950-1, 2nd Edition + AM:2
EMI Compliance	Condition	Standard / Criterion
EMC Conducted and Radiated		EN55022, Class B
ESD		EN61000-4-2, Criteria A

DIMENSION and PHYSICAL CHARACTERISTICS

Parameter	Type	Value
Case Material		non-conductive black plastic (UL94V-0)
Potting Material		epoxy (UL94V-0)
Package Dimension (LxWxH)		12.1 x 9.7 x 24.0mm
Package Weight		4.5g

continued on next page

Specifications (measured @ $t_a = 25^\circ\text{C}$, full load, nominal input voltage and after warm-up)

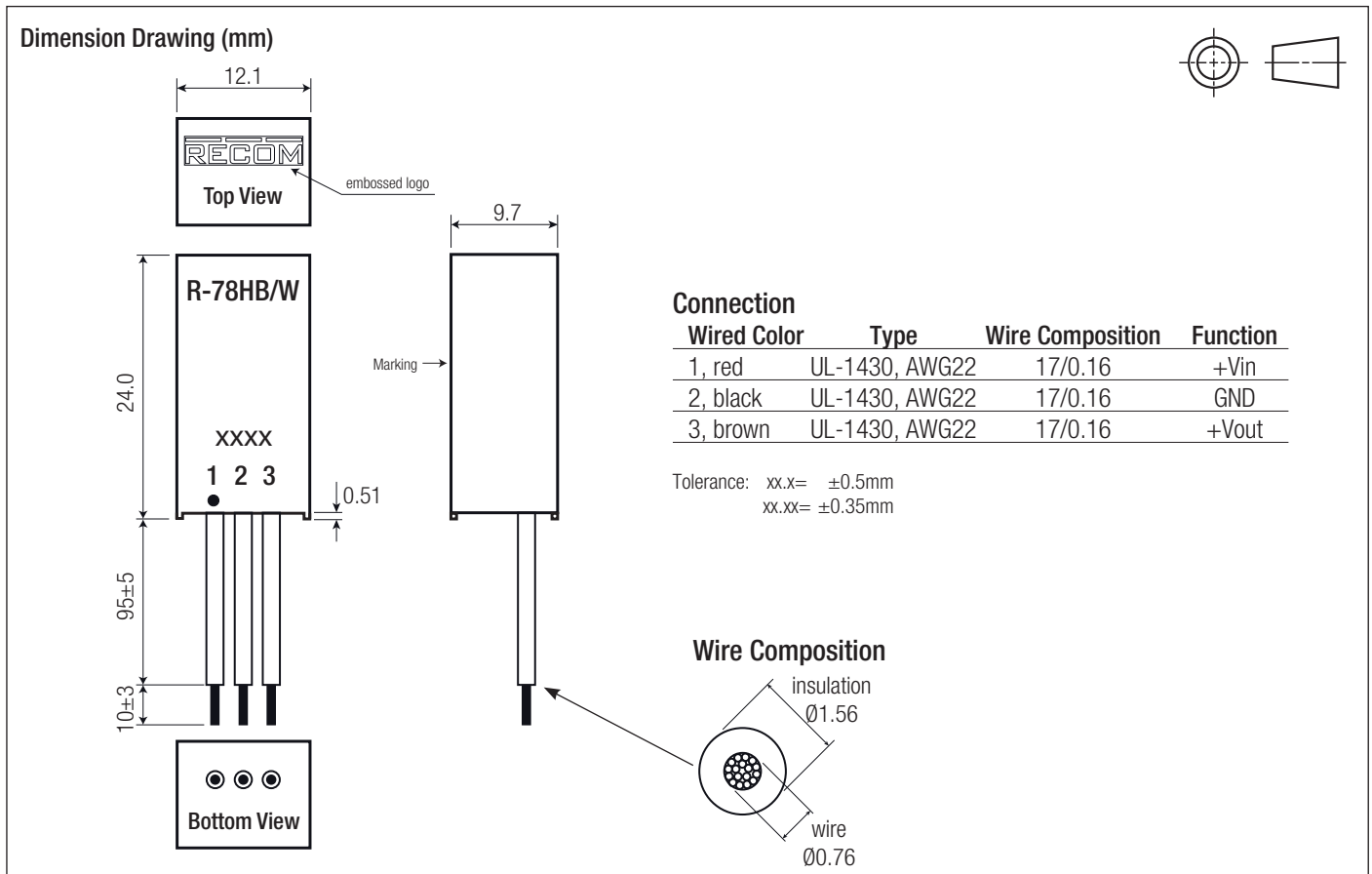

APPLICATION

Standard Application

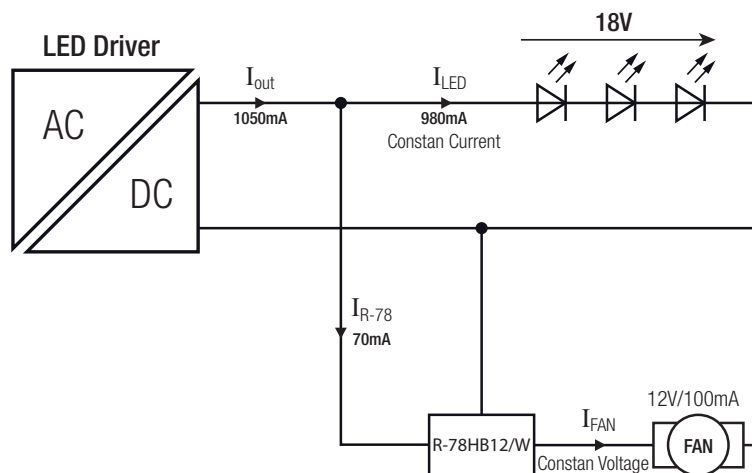

PACKAGING INFORMATION

Packaging Dimension (LxWxH)	cardboard box	140.0 x 130.0 x 65.0mm
Packaging Quantity		25pcs
Storage Temperature Range		-55°C to $+125^\circ\text{C}$
Storage Humidity	non-condensing	95%, RH max.

The product information and specifications are subject to change without prior notice. RECOM products are not authorized for use in safety-critical applications (such as life support) without RECOM's explicit written consent. A safety-critical application is defined as an application where a failure of a RECOM product may reasonably be expected to endanger or cause loss of life, inflict bodily harm or damage property. The buyer shall indemnify and hold harmless RECOM, its affiliated companies and its representatives against any damage claims in connection with the unauthorized use of RECOM products in such safety-critical applications.