



Chipsmall Limited consists of a professional team with an average of over 10 year of expertise in the distribution of electronic components. Based in Hongkong, we have already established firm and mutual-benefit business relationships with customers from,Europe,America and south Asia,supplying obsolete and hard-to-find components to meet their specific needs.

With the principle of “Quality Parts,Customers Priority,Honest Operation,and Considerate Service”,our business mainly focus on the distribution of electronic components. Line cards we deal with include Microchip,ALPS,ROHM,Xilinx,Pulse,ON,Everlight and Freescale. Main products comprise IC,Modules,Potentiometer,IC Socket,Relay,Connector.Our parts cover such applications as commercial,industrial, and automotives areas.

We are looking forward to setting up business relationship with you and hope to provide you with the best service and solution. Let us make a better world for our industry!



## Contact us

Tel: +86-755-8981 8866 Fax: +86-755-8427 6832

Email & Skype: info@chipsmall.com Web: www.chipsmall.com

Address: A1208, Overseas Decoration Building, #122 Zhenhua RD., Futian, Shenzhen, China



**PROPRIETARY INFORMATION:**  
 PROPRIETARY OF GLOBTEK, INC. ANY REPRODUCTION, DISCLOSURE OR USE OF THIS DRAWING, IN WHOLE OR IN PART, IS HEREBY PROHIBITED EXCEPT AS SPECIFIED IN WRITING BY GLOBTEK, INC.

REVISION			
REV	DESCRIPTION	DATE	APPROVED
A	INITIAL RELEASE, RFS. 22658, SO	03/23/12	HM
B	UPDATE DRAWING WITH LOCATING TAB, RFS. 26719, NF	04/07/17	MK

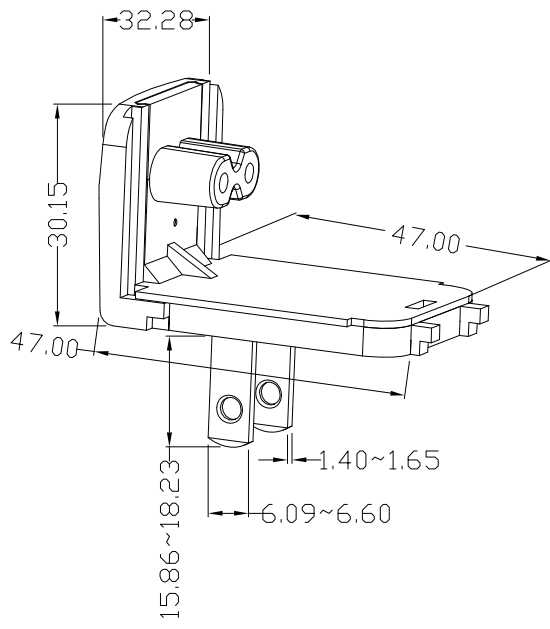

**RELEASED**  
 By N.Frost at 4:40 pm, Apr 07, 2017

DASH NO.	PART NO	REV.	DESCRIPTION	NOTES
<b>TABULATION BLOCK</b>				
		<b>TOLERANCES:</b> DECIMALS    ANGULAR .xx +/- 0.1    +/- 1° .xxx +/- .005		<b>GlobTek, Inc.</b> www.globtek.com 186 Veterans Dr. Northvale, NJ 07647 Tel. 201-784-1000 Fax 201.784.0111
		MILLIMETERS    ANGULAR .xx +/- 0.3    +/- 1° .xxx +/- .013		
INIT.BY: SO	DATE: 03/23/12	DWG TITLE: CHANGEABLE BLADE T2-NA		
DRAWN: NF	DATE: 03/23/12	FSCN No.: G, CC	SIZE A	MODEL: REV. B
APRVD: HM	DATE: 03/23/12	SCALE: NONE	PART NO: <b>R-NA-2(R)</b>	SHEET 1/1

**Foot Note:**  
 Globtek Inc. will not be liable for the safety and performance of these power product if unauthorized access and repair occurs. End user should consult the applicable UL, CSA or EN Standards for proper installation instruction.

**Limitation of Use:**  
 Globtek product are not authorized for use as mission critical components in life support, hazardous environment, nuclear or aircraft applications without prior written approval from the CEO of Globtek Inc.

Contents of this document are subject to change without prior notice