



Chipsmall Limited consists of a professional team with an average of over 10 year of expertise in the distribution of electronic components. Based in Hongkong, we have already established firm and mutual-benefit business relationships with customers from,Europe,America and south Asia,supplying obsolete and hard-to-find components to meet their specific needs.

With the principle of “Quality Parts,Customers Priority,Honest Operation,and Considerate Service”,our business mainly focus on the distribution of electronic components. Line cards we deal with include Microchip,ALPS,ROHM,Xilinx,Pulse,ON,Everlight and Freescale. Main products comprise IC,Modules,Potentiometer,IC Socket,Relay,Connector.Our parts cover such applications as commercial,industrial, and automotives areas.

We are looking forward to setting up business relationship with you and hope to provide you with the best service and solution. Let us make a better world for our industry!



## Contact us

Tel: +86-755-8981 8866 Fax: +86-755-8427 6832

Email & Skype: info@chipsmall.com Web: www.chipsmall.com

Address: A1208, Overseas Decoration Building, #122 Zhenhua RD., Futian, Shenzhen, China



To our customers,

---

## Old Company Name in Catalogs and Other Documents

---

On April 1<sup>st</sup>, 2010, NEC Electronics Corporation merged with Renesas Technology Corporation, and Renesas Electronics Corporation took over all the business of both companies. Therefore, although the old company name remains in this document, it is a valid Renesas Electronics document. We appreciate your understanding.

Renesas Electronics website: <http://www.renesas.com>

April 1<sup>st</sup>, 2010  
Renesas Electronics Corporation

Issued by: Renesas Electronics Corporation (<http://www.renesas.com>)

Send any inquiries to <http://www.renesas.com/inquiry>.

## Notice

1. All information included in this document is current as of the date this document is issued. Such information, however, is subject to change without any prior notice. Before purchasing or using any Renesas Electronics products listed herein, please confirm the latest product information with a Renesas Electronics sales office. Also, please pay regular and careful attention to additional and different information to be disclosed by Renesas Electronics such as that disclosed through our website.
2. Renesas Electronics does not assume any liability for infringement of patents, copyrights, or other intellectual property rights of third parties by or arising from the use of Renesas Electronics products or technical information described in this document. No license, express, implied or otherwise, is granted hereby under any patents, copyrights or other intellectual property rights of Renesas Electronics or others.
3. You should not alter, modify, copy, or otherwise misappropriate any Renesas Electronics product, whether in whole or in part.
4. Descriptions of circuits, software and other related information in this document are provided only to illustrate the operation of semiconductor products and application examples. You are fully responsible for the incorporation of these circuits, software, and information in the design of your equipment. Renesas Electronics assumes no responsibility for any losses incurred by you or third parties arising from the use of these circuits, software, or information.
5. When exporting the products or technology described in this document, you should comply with the applicable export control laws and regulations and follow the procedures required by such laws and regulations. You should not use Renesas Electronics products or the technology described in this document for any purpose relating to military applications or use by the military, including but not limited to the development of weapons of mass destruction. Renesas Electronics products and technology may not be used for or incorporated into any products or systems whose manufacture, use, or sale is prohibited under any applicable domestic or foreign laws or regulations.
6. Renesas Electronics has used reasonable care in preparing the information included in this document, but Renesas Electronics does not warrant that such information is error free. Renesas Electronics assumes no liability whatsoever for any damages incurred by you resulting from errors in or omissions from the information included herein.
7. Renesas Electronics products are classified according to the following three quality grades: “Standard”, “High Quality”, and “Specific”. The recommended applications for each Renesas Electronics product depends on the product’s quality grade, as indicated below. You must check the quality grade of each Renesas Electronics product before using it in a particular application. You may not use any Renesas Electronics product for any application categorized as “Specific” without the prior written consent of Renesas Electronics. Further, you may not use any Renesas Electronics product for any application for which it is not intended without the prior written consent of Renesas Electronics. Renesas Electronics shall not be in any way liable for any damages or losses incurred by you or third parties arising from the use of any Renesas Electronics product for an application categorized as “Specific” or for which the product is not intended where you have failed to obtain the prior written consent of Renesas Electronics. The quality grade of each Renesas Electronics product is “Standard” unless otherwise expressly specified in a Renesas Electronics data sheets or data books, etc.
  - “Standard”: Computers; office equipment; communications equipment; test and measurement equipment; audio and visual equipment; home electronic appliances; machine tools; personal electronic equipment; and industrial robots.
  - “High Quality”: Transportation equipment (automobiles, trains, ships, etc.); traffic control systems; anti-disaster systems; anti-crime systems; safety equipment; and medical equipment not specifically designed for life support.
  - “Specific”: Aircraft; aerospace equipment; submersible repeaters; nuclear reactor control systems; medical equipment or systems for life support (e.g. artificial life support devices or systems), surgical implantations, or healthcare intervention (e.g. excision, etc.), and any other applications or purposes that pose a direct threat to human life.
8. You should use the Renesas Electronics products described in this document within the range specified by Renesas Electronics, especially with respect to the maximum rating, operating supply voltage range, movement power voltage range, heat radiation characteristics, installation and other product characteristics. Renesas Electronics shall have no liability for malfunctions or damages arising out of the use of Renesas Electronics products beyond such specified ranges.
9. Although Renesas Electronics endeavors to improve the quality and reliability of its products, semiconductor products have specific characteristics such as the occurrence of failure at a certain rate and malfunctions under certain use conditions. Further, Renesas Electronics products are not subject to radiation resistance design. Please be sure to implement safety measures to guard them against the possibility of physical injury, and injury or damage caused by fire in the event of the failure of a Renesas Electronics product, such as safety design for hardware and software including but not limited to redundancy, fire control and malfunction prevention, appropriate treatment for aging degradation or any other appropriate measures. Because the evaluation of microcomputer software alone is very difficult, please evaluate the safety of the final products or system manufactured by you.
10. Please contact a Renesas Electronics sales office for details as to environmental matters such as the environmental compatibility of each Renesas Electronics product. Please use Renesas Electronics products in compliance with all applicable laws and regulations that regulate the inclusion or use of controlled substances, including without limitation, the EU RoHS Directive. Renesas Electronics assumes no liability for damages or losses occurring as a result of your noncompliance with applicable laws and regulations.
11. This document may not be reproduced or duplicated, in any form, in whole or in part, without prior written consent of Renesas Electronics.
12. Please contact a Renesas Electronics sales office if you have any questions regarding the information contained in this document or Renesas Electronics products, or if you have any other inquiries.

(Note 1) “Renesas Electronics” as used in this document means Renesas Electronics Corporation and also includes its majority-owned subsidiaries.

(Note 2) “Renesas Electronics product(s)” means any product developed or manufactured by or for Renesas Electronics.

---

# R8C/26, 27 Group IC Socket Board

## R0K521276Z000BR

### Release Note, Version 1.00

Renesas Solutions Corp.

May 1, 2007

Thank you for purchasing the R8C/26, 27 IC socket board (R0K521276Z000BR).

This release note describes how to use the IC socket board. Be sure to read this note before using the product.

#### Table of Contents

1. Introduction.....	2
2. Notes on Use – Please Read This Carefully! .....	2
3. Product Overview .....	2
4. Product Specifications.....	2
5. Contents of Package .....	3
6. IC Socket Board Configuration .....	3
6.1. External Specifications .....	3
6.2. External Power Supply Specifications.....	3
6.3. Jumper Specifications.....	3
6.4. Switch Specifications .....	3
6.5. Connector Specifications.....	4
7. How to Use .....	5
7. How to Use .....	5
7.1. Setup .....	5
7.2. Programming Procedures.....	5
8. Obtaining the Latest Information .....	5

---

## 1. Introduction

This release note describes usage and notes for the hardware included in the IC socket board (R0K521276Z000BR).

## 2. Notes on Use – Please Read This Carefully!

### [Removing the MCU]

To remove the MCU from the IC socket when the IC socket board is in use, make sure that the power supply switch on the IC socket board is turned off before removing.

### [Connecting the Flash Programmer]

Communication connectors CN1 and CN2 on the IC socket board are individually connected with the wired OR. Do not connect multiple flash programmers to the IC socket board. If the IC socket board is used when multiple flash programmers are connected, the MCU and flash programmer may be damaged.

## 3. Product Overview

The IC socket board is a write-only IC socket board for programming the R8C/26, 27 flash MCUs via various flash programmers.

### Applicable MCUs \*1

R8C/26, 27 Group 32-Pin Version Flash MCUs (Package: PLQP0032GB-A)

\*1: Some MCUs may not be applicable depending on the flash programmer used. Check the applicable MCUs for the flash programmer.

### Applicable Flash Programmers

Renesas Technology Corp.

- Flash Development Toolkit
  - Flash Starter (M3A-0806)
- Web site: <http://www.renesas.com/>

## 4. Product Specifications

Table 4-1 shows the IC Socket Board Specifications.

Table 4-1 IC Socket Board Specifications

Parameter		
Operating Voltage		5.0 V $\pm$ 5 % (Supply from external power supply)
Operating Environment	1. Operating Ambient Temperature	20 °C $\pm$ 5 °C
	2. Humidity	No dew condensation allowed



---

## 5. Contents of Package

Table 5-1 shows the Contents of the IC Socket Board Package.

Table 5-1 Contents of IC Socket Board Package

Product Name	Quantity	Remark
IC Socket Board (R0K521276Z000BR)	1	
Power Supply Cable	1	
Release Note	2	Japanese - 1, English - 1

## 6. IC Socket Board Configuration

### 6.1. External Specifications

Table 6-1 shows the External IC Socket Board Specifications.

Table 6-1 External IC Socket Board Specifications

Item	Description	Remark
Connector	CN1: Communication connector	10-Pin Connector
	CN2: Communication connector	14-Pin Connector
	CN3: Power supply connector	
IC Socket	IC1: 32-pin IC socket	PLQP0032GB-A
Oscillator	CST1: Unimplemented	
Switch	SW1: Tactile-type power supply switch	
LED	LED1: Power supply indicator	
Jumper	JP1: For MODE pin "L" input switching	

### 6.2. External Power Supply Specifications

Single Power Supply Connector (CN3)

An external power supply is necessary. Apply 5.0 V  $\pm$ 5 % to the connector.

### 6.3. Jumper Specifications

JP1

JP1 is used for "L" input switching of the MODE pin (8 pins). Table 6-2 shows the JP1 Settings.

Table 6-2 JP1 Settings

Jumper Setting	Description	Remark
Open	Pull-up	Default
Short	"L" input	

### 6.4. Switch Specifications

SW1 is used for the power supply switch on the IC socket board.

## 6.5. Connector Specifications

1) CN1: 10-pin connector

Table 6-3 shows the CN1 Pin Assignment.

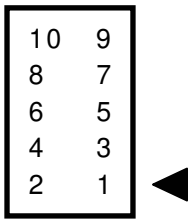

Table 6-3 CN1 Pin Assignment

Pin No.	Signal *1
1	Vcc
2	-----
3	MODE
4	(RxD *2)
5	-----
6	-----
7	GND
8	RESET
9	-----
10	(TxD *2)

\*1: MCU signal name

\*2: Communication pin for Flash Starter (M3A-0806)

CN1 Reference

Product Name: 2.54 mm Pitch 10-Pin Connector (Straight)

Part Number: HIF3FC-10PA-2.54DSA

Manufacturer: Hirose Electric Co., Ltd

2) CN2: 14-pin connector

Table 6-4 shows the CN2 Pin Assignment.

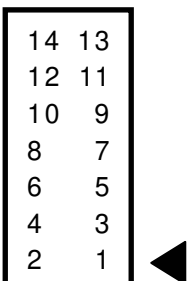

Table 6-4 CN2 Pin Assignment

Pin No.	Signal *1
1	N.C.
2	GND
3	N.C.
4	GND
5	N.C.
6	GND
7	MODE
8	Vcc
9	N.C.
10	GND
11	N.C.
12	GND
13	RESET
14	GND

\*1: MCU signal name

CN2 Reference

Product Name: 2.54 mm Pitch 14-Pin Connector (Straight)

Part Number: 7614-6002

Manufacturer: Sumitomo 3M Limited

---

## 7. How to Use

### 7.1. Setup

- Procedure 1 Connect an external power supply to the IC socket board.  
\*The IC socket board, MCU or flash programmer may be damaged due to incorrect insertion. Make sure that the polarity of the power supply is correct.
- Procedure 2 Connect the flash programmer to the connector CN1 (CN2 for E8).  
Only when the Flash Starter (M3A-0806) is used, short JP1 and implement the 20 MHz oscillator.
- Procedure 3 Supply power from the external power supply.  
Make sure that the power LED on the IC socket board is off at this time.  
\*If the power LED is on, press down on the power switch to turn off the LED.
- The setup is now complete.

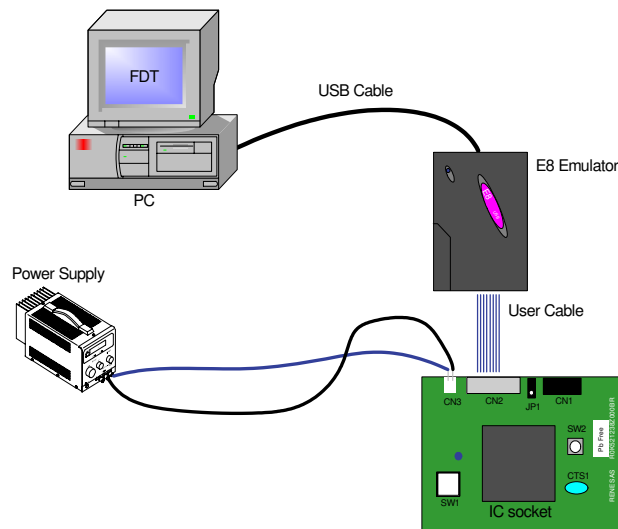

**Figure 7.1 IC Socket Board Connection Example**

### 7.2. Programming Procedures

- Procedure 1 Mount the MCU into the IC socket on the IC socket board.  
\*The MCU may be damaged due to incorrect insertion. Make sure that it is inserted in the correct direction.
- Procedure 2 Press down on the power switch and check that the power LED is on.
- Procedure 3 Program the MCU internal flash memory using the flash programmer.  
\*Refer to the programmer manual of the flash programmer before programming.
- Procedure 4 Press down on the power switch and check that the power LED is off.  
When the LED is off, remove the MCU from the IC socket board.  
It is possible to go back to the procedure 1 and continue programming the MCU.

## 8. Obtaining the Latest Information

For the latest product information on this product, please visit our website below:  
<http://www.renesas.com/>