



Chipsmall Limited consists of a professional team with an average of over 10 year of expertise in the distribution of electronic components. Based in Hongkong, we have already established firm and mutual-benefit business relationships with customers from,Europe,America and south Asia,supplying obsolete and hard-to-find components to meet their specific needs.

With the principle of “Quality Parts,Customers Priority,Honest Operation,and Considerate Service”,our business mainly focus on the distribution of electronic components. Line cards we deal with include Microchip,ALPS,ROHM,Xilinx,Pulse,ON,Everlight and Freescale. Main products comprise IC,Modules,Potentiometer,IC Socket,Relay,Connector.Our parts cover such applications as commercial,industrial, and automotives areas.

We are looking forward to setting up business relationship with you and hope to provide you with the best service and solution. Let us make a better world for our industry!



Contact us

Tel: +86-755-8981 8866 Fax: +86-755-8427 6832

Email & Skype: info@chipsmall.com Web: www.chipsmall.com

Address: A1208, Overseas Decoration Building, #122 Zhenhua RD., Futian, Shenzhen, China



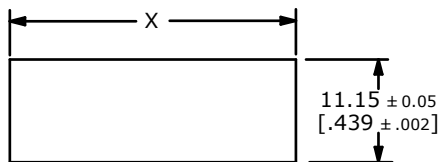

RECOMMENDED PANEL MOUNTING

PANEL THICKNESS	X ± 0.05
0.75-1.25	29.65
1.25-2.00	30.15
2.00-3.00	30.50

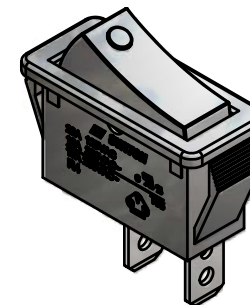
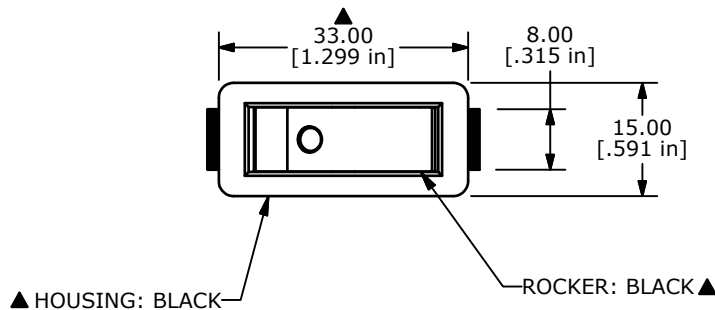

SWITCH FUNCTION	
POS. 1	POS. 3
ON	(OFF)
1-1a	OPEN

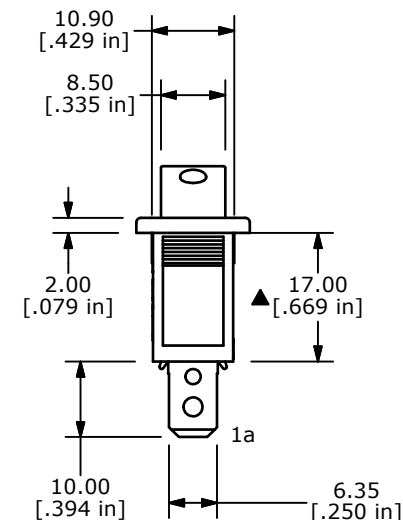
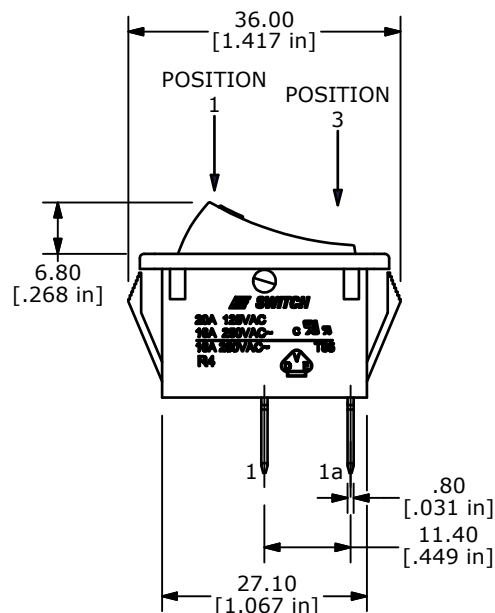
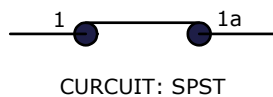

NOTES:

1. ALL DIMENSIONS IN MM [INCH]
2. GENERAL TOLERANCE: X.X ± 0.4
X.XX ± 0.25
3. TERM. NOS. FOR REF. ONLY
- ▲ 4. RATING: 20A 125VAC, 16A 250VAC UL APPROVED
16A 250VAC VDE APPROVED
5. ELECTRICAL LIFE: OVER 10,000 CYCLES
6. MECHANICAL LIFE: OVER 30,000 CYCLES
7. CONTACT RESISTANCE: <20 mΩ (INITIAL)
8. DIELECTRIC STRENGTH: >1500V 1 min
9. INSULATION RESISTANCE: >1,000 mΩ @ 500V DC
10. OPERATING TEMPERATURE: TERMINAL SIDE -20°C to 85°C
ROCKER SIDE -20°C to 55°C
11. ▲ DENOTES CRITICAL PARAMETER
12. 2002/95/EC (ROHS) COMPLIANT



TITLE R4HBLKBLKEF0				
SCALE 1:1	DATE 3/31/1999	DR MM	DWG M040111	REV F

F	19888	UPDATE DRAWING	04/27/11	BMA
E	15996	UPDATE NOTES AND DIMS	05/02/06	CT
REV	PCR NO	DESCRIPTION	DATE	BY

THE INFORMATION CONTAINED IN THIS DOCUMENT IS PROPRIETARY TO E-SWITCH AND IS NOT TO BE COPIED OR TRANSFERRED