



Chipsmall Limited consists of a professional team with an average of over 10 year of expertise in the distribution of electronic components. Based in Hongkong, we have already established firm and mutual-benefit business relationships with customers from,Europe,America and south Asia,supplying obsolete and hard-to-find components to meet their specific needs.

With the principle of “Quality Parts,Customers Priority,Honest Operation,and Considerate Service”,our business mainly focus on the distribution of electronic components. Line cards we deal with include Microchip,ALPS,ROHM,Xilinx,Pulse,ON,Everlight and Freescale. Main products comprise IC,Modules,Potentiometer,IC Socket,Relay,Connector.Our parts cover such applications as commercial,industrial, and automotives areas.

We are looking forward to setting up business relationship with you and hope to provide you with the best service and solution. Let us make a better world for our industry!



Contact us

Tel: +86-755-8981 8866 Fax: +86-755-8427 6832

Email & Skype: info@chipsmall.com Web: www.chipsmall.com

Address: A1208, Overseas Decoration Building, #122 Zhenhua RD., Futian, Shenzhen, China



RapID™ Platform – EtherNet/IP Network Interface with DLR 2-Port Connectivity Solution with Device Level Ring

EtherNet/IP™

The RapID Platform Network Interface is a complete, pre-tested solution that manages the industrial protocol and network traffic for a host processor

The *Network Interface* module or embedded design contains everything needed to participate in star, line, or ring network topologies including the communications controller, protocol stacks, Flash, RAM, Ethernet switch and PHYs. A host processor connects to the *Network Interface* via a UART or 16-bit Parallel Interface. At the software layer the host connects to a “Unified Interface” so **other protocols can be used without changing the host software**. The *Network Interface* has passed EtherNet/IP CT11 certification for beacon-based DLR devices and has been Net Load tested by Innovasic. This means your field device will operate problem-free on any EtherNet/IP network and will never disconnect from the network.

Easy Hardware and Software Integration

The *Network Interface* can be integrated into a design as either a **module or an embedded design**. As a module, the *Network Interface* plugs into a board using standard 2.54 mm pitch through-hole pins. When designing-in the module, hardware integration is as easy as connecting Power/Ground/Reset and interfacing the Host to the UART or 16-bit Parallel interface.

As an embedded design, **the *Network Interface* hardware design can be integrated directly using the schematics provided**. Also provided are the Bill of Materials and example layouts to minimize the hardware design effort. Software for the embedded design is provided as firmware that is downloaded to the flash. Whether using the *Network Interface* as a module or an embedded design, **no software development is required and there are no license fees or royalties**.

Software integration with a Host is also easy. Messages passed between the Host and *Network Interface* follow a “Unified Interface” definition. A simple to use, Innovasic supplied, **PC-based tool configures the *Network Interface***, so the Host only passes parameters between it and the *Network Interface*. From this tool, it is also easy to specify how parameters will be passed to the EtherNet/IP scanner using the EDS file. Since the Host is only passing parameters, the Host software does not have to change if EtherNet/IP network parameters change or if another Industrial Ethernet protocol is used. There is also a “sockets” interface that supports direct Ethernet communication. Example C-code is provided to minimize the software effort for the Host / *Network Interface* communication.

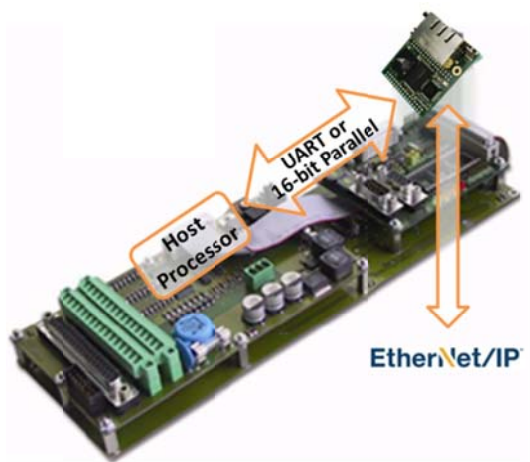
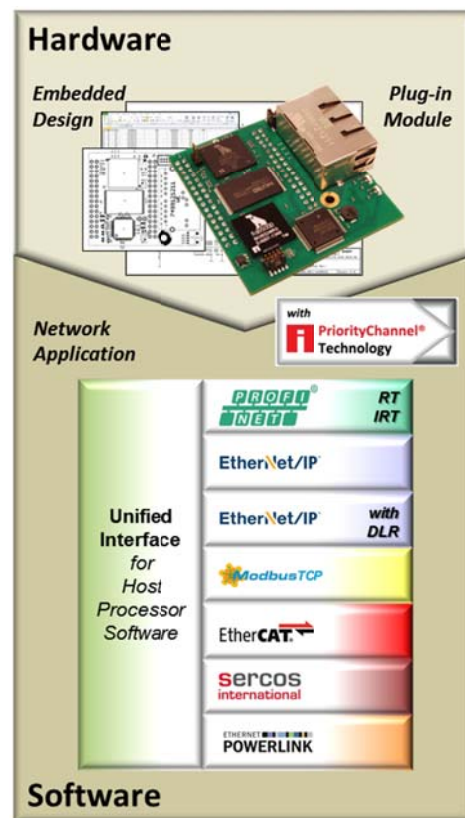

RapID™ Platform – EtherNet/IP Network Interface with DLR

2-Port Connectivity Solution with Device Level Ring

EtherNet/IP™

Reliable, Flexible Network Integration

The *RapID Platform Network Interface* provides reliable EtherNet/IP communication with PriorityChannel™ – a revolutionary technology that eliminates the effects of network traffic and ensures reliable, real-time network performance. **It gives your device a significant competitive advantage**, extremely low jitter, and a reliable connection that **will not disconnect even with >95% network loading**.

EtherNet/IP support includes Dynamic Host Configuration Protocol (DHCP) and Address Conflict Detection (ACD). Together, these two protocols ensure seamless integration allowing devices to be easily added or removed from the network. DLR protocol operation is transparent to the host processor, and beacon-based ring participation is supported with **beacon intervals down to 200 μs**. The platform supports all **EtherNet/IP message types – implicit, explicit, and unconnected** – and allows up to 8 Encapsulation Session, 16 Class 1 connections, and 16 Class 3 connections. Large Forward Open and Configuration Assemblies are also supported, and the example EDS file provided can be tailored and uploaded to an EtherNet/IP scanner. To assist with commissioning, **a webserver is provided** so the field device’s network information can be displayed on a standard browser.

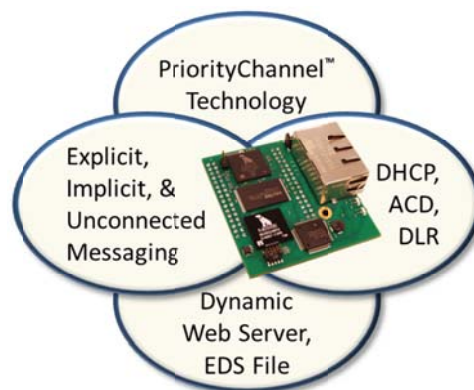

Fast Evaluation and Development

The *RapID Platform Network Interface Evaluation Kit* provides a quick assessment for interfacing a Host to the module. An application example is provided in order to demonstrate end-to-end, Host-to-Network Interface-to-Controller communication. Simply connect the Host development board to the *Network Interface* evaluation board via the UART or 16-bit Parallel interface. Once Host-side communication is established, EtherNet/IP communication can be evaluated using a PLC or Controller simulator. The communication path between Host and EtherNet/IP scanner can be completely verified before integrating the module into your field device hardware.



RapID Platform EtherNet/IP Network Interface with DLR	
Parameter	Details
Host Processor	Any CPU or DSP
Host Processor Interfaces	UART (115.2 kBaud) 16-bit Parallel (up to 12.5 Mbps)
Network Interface	Data Transport: IEEE 802.3
	Data Rate: 10/100 Mbps Ports: 2
Temperature	-40C to +85C
Power Supply	Voltage: 3.3 VDC
	Power consumption: 1.6W
TCP/IP	ICMP, IGMP, ARP, SNTP, BSD Sockets, DNS, DHCP, TELNET, TFTP, HTTP server, CGI
EtherNet/IP	Input Data: 504 bytes Output Data: 504 bytes
	Packet Interval: 2 ms (min.)
	Beacon Interval: down to 200 μs
	Supported Objects: Identity, Message Router, Assembly, Connection, Connection Manager, DLR, QoS, TCP/IP Interface, Ethernet Link
	Explicit and Unconnected Messaging
	Address Conflict Detection
Compliance	RoHS, CE, ODVA