



Chipsmall Limited consists of a professional team with an average of over 10 year of expertise in the distribution of electronic components. Based in Hongkong, we have already established firm and mutual-benefit business relationships with customers from,Europe,America and south Asia,supplying obsolete and hard-to-find components to meet their specific needs.

With the principle of "Quality Parts,Customers Priority,Honest Operation,and Considerate Service",our business mainly focus on the distribution of electronic components. Line cards we deal with include Microchip,ALPS,ROHM,Xilinx,Pulse,ON,Everlight and Freescale. Main products comprise IC,Modules,Potentiometer,IC Socket,Relay,Connector.Our parts cover such applications as commercial,industrial, and automotives areas.

We are looking forward to setting up business relationship with you and hope to provide you with the best service and solution. Let us make a better world for our industry!



Contact us

Tel: +86-755-8981 8866 Fax: +86-755-8427 6832

Email & Skype: info@chipsmall.com Web: www.chipsmall.com

Address: A1208, Overseas Decoration Building, #122 Zhenhua RD., Futian, Shenzhen, China



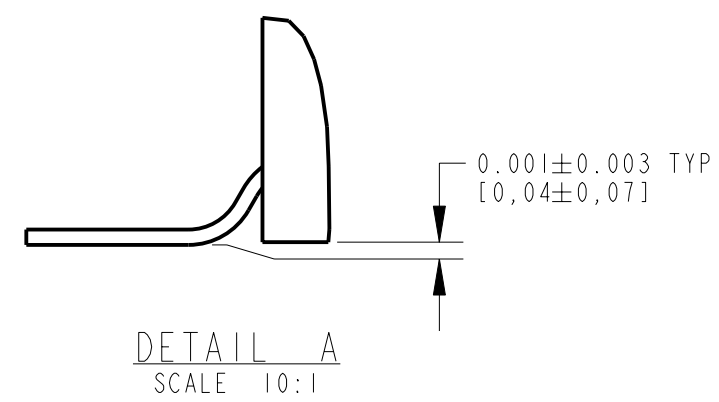
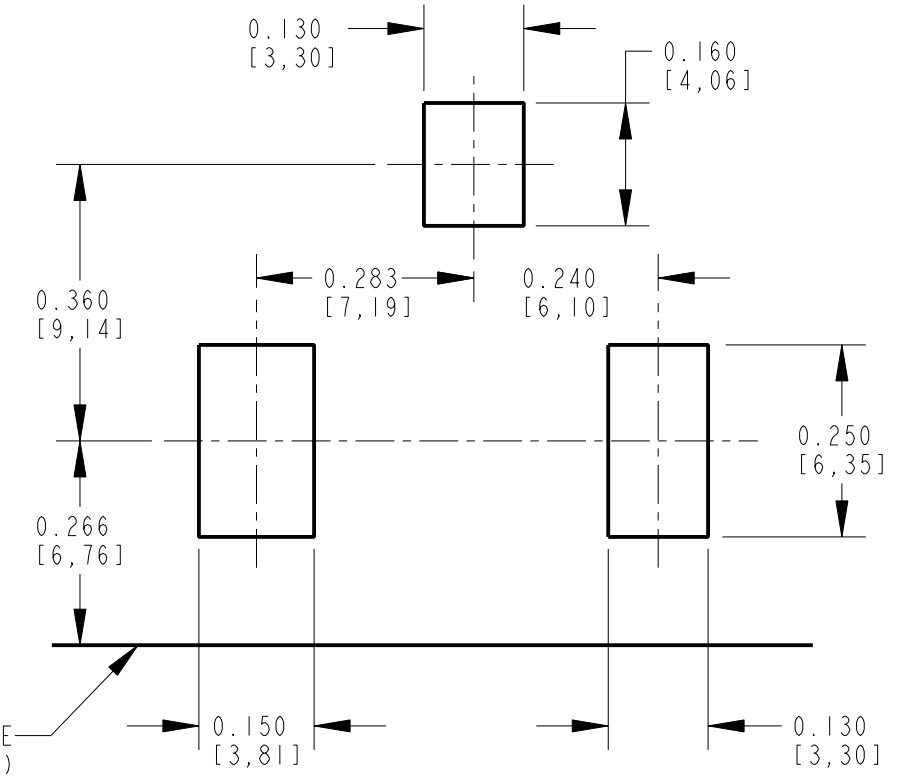
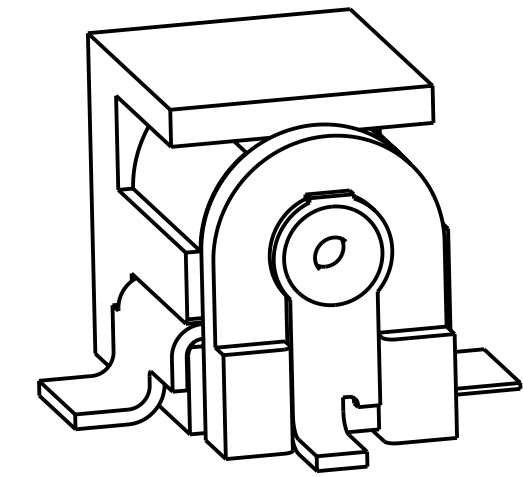
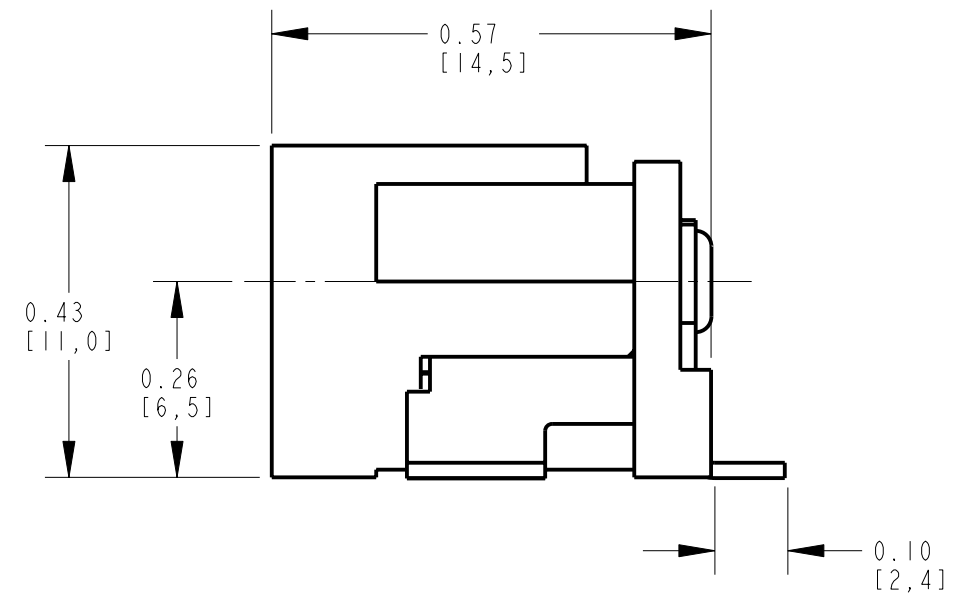
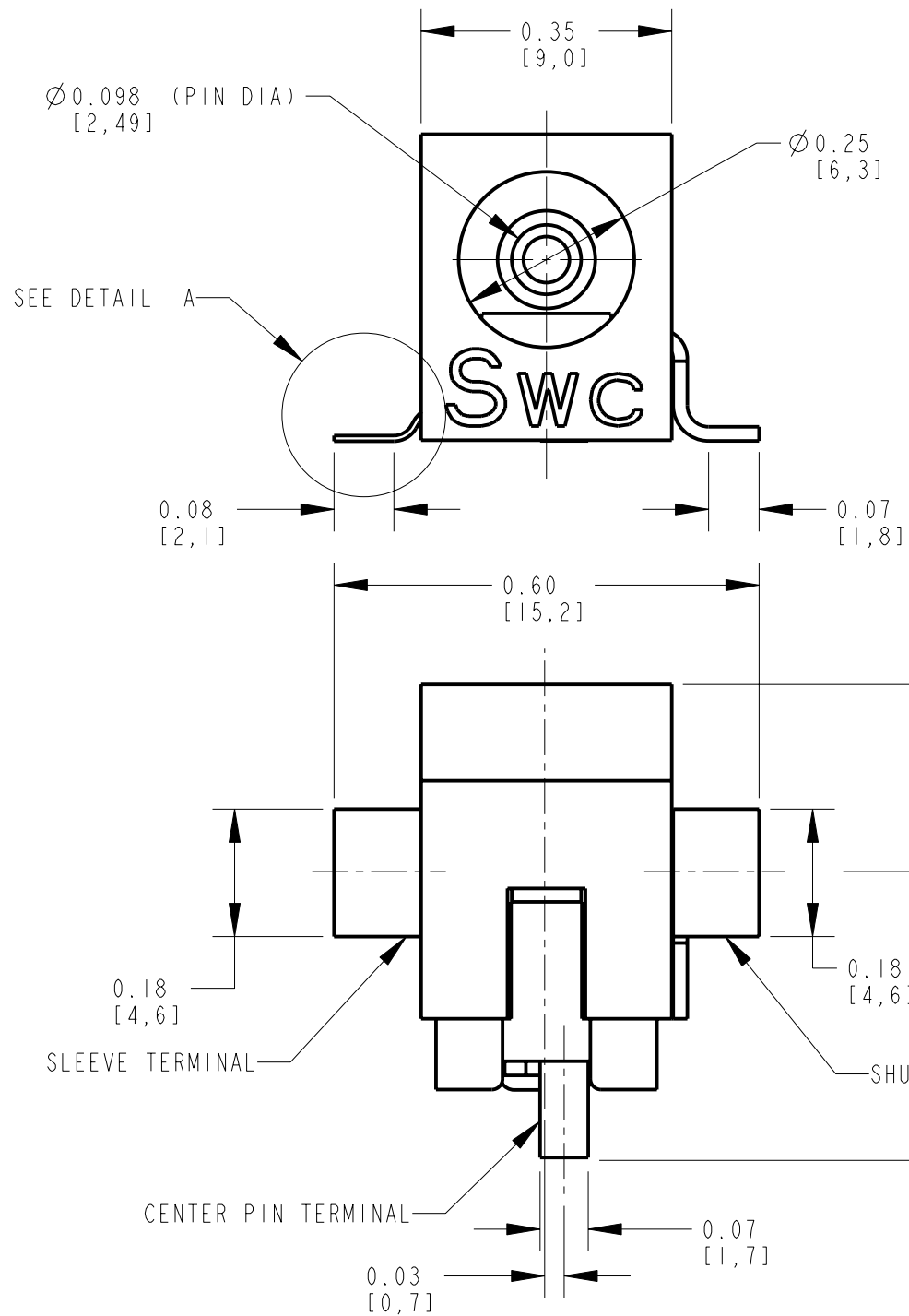

MATERIALS:
 HOUSING AND COVER: HIGH GRADE THERMOPLASTIC, UL94V-0 RATED, COLOR BLACK.
 CENTER PIN: BRASS, NICKEL PLATED PER QQ-N-290, CLASS 1.
 PIN AND SHUNT TERMINALS: BRASS, SOLDER PLATED.
 SLEEVE SPRING: SPRING COPPER ALLOY, SOLDER PLATED.

SPECIFICATIONS:
 LIFE: 5000 CYCLES.
 INSERTION FORCE: 5 LB [2.3 KG] MAX.
 WITHDRAWAL FORCE: 0.5 LB [0.2 KG] MIN.
 CONTACT RESISTANCE: 30 MILLIOHM MAX, 60 MILLIOHM MAX. AFTER TEST.
 INSULATION RESISTANCE: 30 MEGAOHM MIN. @ 100VDC.
 DIELECTRIC WITHSTANDING VOLTAGE: 250VAC FOR 1 MINUTE.
 CURRENT (CARRYING): 5A.

REV	ECO NUMBER	DATE	BY	APVD
C	24089	12-12-02	JL	MW
B	22891	6-15-99	TJK	TJK
A	20611	7-22-97	DA	MA

★ STAR SYMBOL DENOTES CRITICAL DIMENSION

UNLESS OTHERWISE SPECIFIED

- ALL DIMENSIONS IN INCHES
 - TWO PLACE DECIMALS ±0.01
 - THREE PLACE DECIMALS ±0.005
 - ANGLES ±1°
 - ALL DIA. CONCENTRIC WITHIN 0.005 T.I.R.
- FEATURES ON THE SAME CENTERLINE MUST BE ALIGNED WITHIN ±0.002
- REMOVE ALL BURRS

DO NOT SCALE DRAWING

THIS DRAWING DESCRIBES A DESIGN CONSIDERED PROPRIETARY IN NATURE, DEVELOPED AND MANUFACTURED BY SWITCHCRAFT INC. AND IS RELEASED ON A CONFIDENTIAL BASIS FOR IDENTIFICATION PURPOSES ONLY.										
SIZE	WIDTH	MULT	LBS/M	TEMPER						
FINISH					MATERIAL					
SPEC No.					SPEC No.					
FIRST USED ON				SCALE						
				4:1						
DATE DRAWN	BY	CHKD	APVD	Switchcraft®						
4-28-95	MA	MA	MA	SHEET 1 OF 1						
				12-28-95				12-28-95		
NAME POWER JACK, SURFACE MOUNT								PART No.		
0.10 [2,5mm] PIN								RASM712		
								REV		
								C		

CUSTOMER DRAWING