



Chipsmall Limited consists of a professional team with an average of over 10 year of expertise in the distribution of electronic components. Based in Hongkong, we have already established firm and mutual-benefit business relationships with customers from,Europe,America and south Asia,supplying obsolete and hard-to-find components to meet their specific needs.

With the principle of “Quality Parts,Customers Priority,Honest Operation,and Considerate Service”,our business mainly focus on the distribution of electronic components. Line cards we deal with include Microchip,ALPS,ROHM,Xilinx,Pulse,ON,Everlight and Freescale. Main products comprise IC,Modules,Potentiometer,IC Socket,Relay,Connector.Our parts cover such applications as commercial,industrial, and automotives areas.

We are looking forward to setting up business relationship with you and hope to provide you with the best service and solution. Let us make a better world for our industry!



## Contact us

Tel: +86-755-8981 8866 Fax: +86-755-8427 6832

Email & Skype: info@chipsmall.com Web: www.chipsmall.com

Address: A1208, Overseas Decoration Building, #122 Zhenhua RD., Futian, Shenzhen, China



RESISTANCE/TEMPERATURE TABLE			
TEMP (°C)	RESIS (Ω)	TEMP (°C)	RESIS (Ω)
-40	212,494	45	4,892
-35	159,470	50	4,142
-30	120,944	55	3,523
-25	92,639	60	3,010
-20	71,626	65	2,581
-15	55,871	70	2,223
-10	43,947	75	1,922
-5	34,842	80	1,667
0	27,831	85	1,451
5	22,390	90	1,268
10	18,134	95	1,111
15	14,782	100	976.3
20	12,123	105	860.7
25	10,000	110	760.9
30	8,298	115	674.5
35	6,923	120	599.6
40	5,805	125	534.3

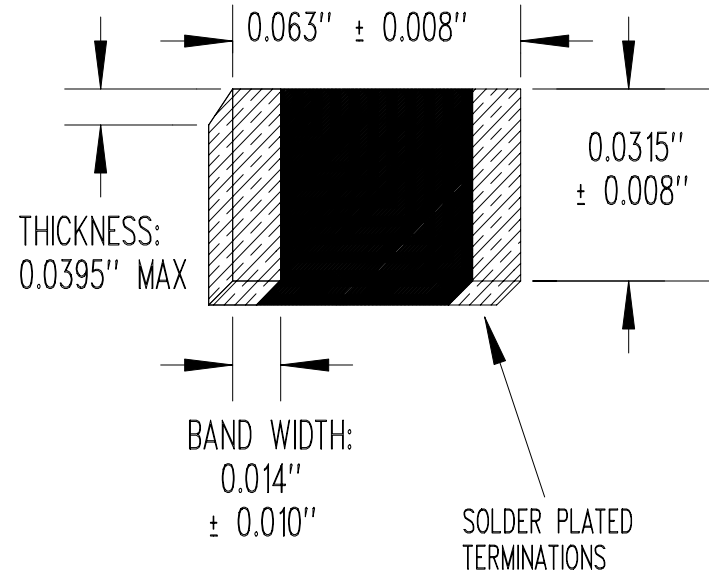

RESISTANCE @ +25°C = 10,000 Ω ± 5%  
 BETA "β" (+25 TO +85°C) = 3,435°K NOMINAL  
 POWER RATING = 150 mW  
 OPERATING TEMPERATURE RANGE = -40 TO +125°C

SEE MANUFACTURING SPECIFICATION (LAYER 1)

NONE	RELEASE TO PRODUCTION	12/11/03	DD
REV	REVISION RECORD	DATE	APP

SCALE	NONE	<b>U.S. SENSOR CORP.</b> 1832 W. COLLINS AVE. ORANGE, CA 92867 714-639-1000 www.ussensor.com
DRAWN BY	DAN DANKERT	
DATE	12/11/03	
REV.	NONE	
LAYER	0 OF 2	
		THERMISTOR, NTC CHIP
		P/N RB103E0J