



Chipsmall Limited consists of a professional team with an average of over 10 year of expertise in the distribution of electronic components. Based in Hongkong, we have already established firm and mutual-benefit business relationships with customers from,Europe,America and south Asia,supplying obsolete and hard-to-find components to meet their specific needs.

With the principle of “Quality Parts,Customers Priority,Honest Operation,and Considerate Service”,our business mainly focus on the distribution of electronic components. Line cards we deal with include Microchip,ALPS,ROHM,Xilinx,Pulse,ON,Everlight and Freescale. Main products comprise IC,Modules,Potentiometer,IC Socket,Relay,Connector.Our parts cover such applications as commercial,industrial, and automotives areas.

We are looking forward to setting up business relationship with you and hope to provide you with the best service and solution. Let us make a better world for our industry!



## Contact us

Tel: +86-755-8981 8866 Fax: +86-755-8427 6832

Email & Skype: info@chipsmall.com Web: www.chipsmall.com

Address: A1208, Overseas Decoration Building, #122 Zhenhua RD., Futian, Shenzhen, China



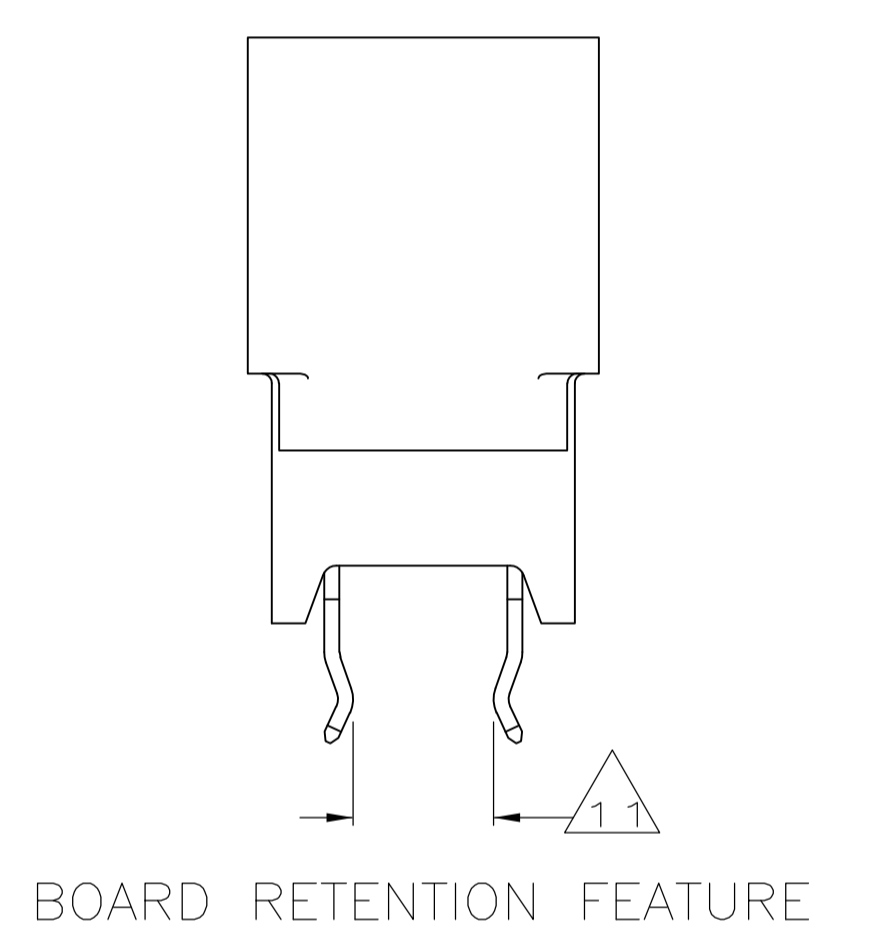
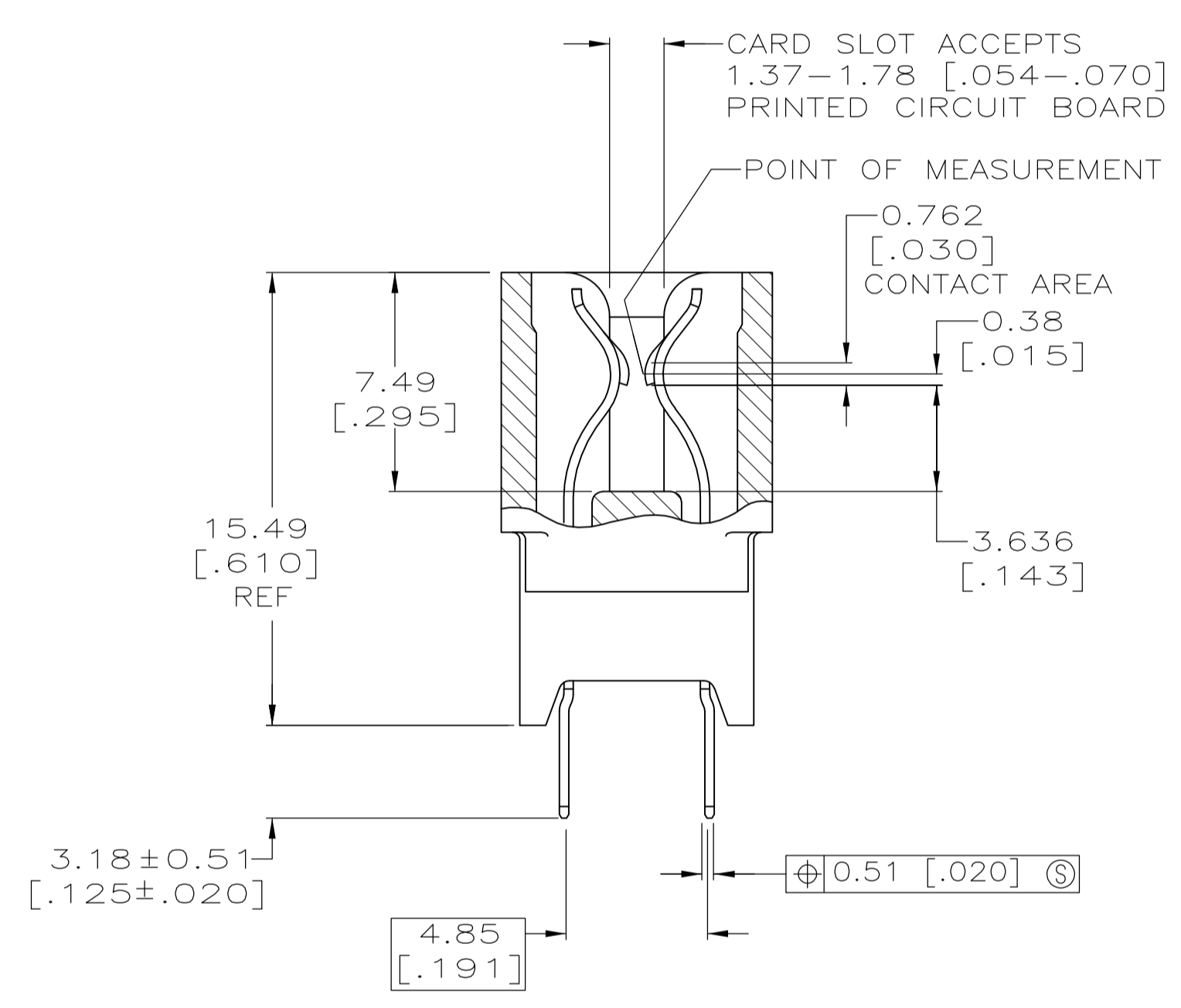
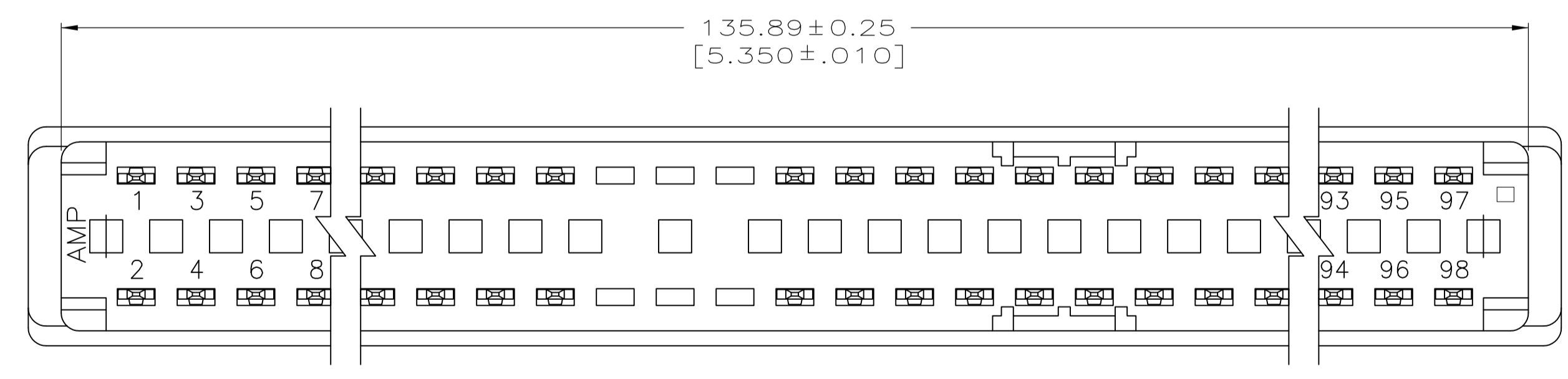
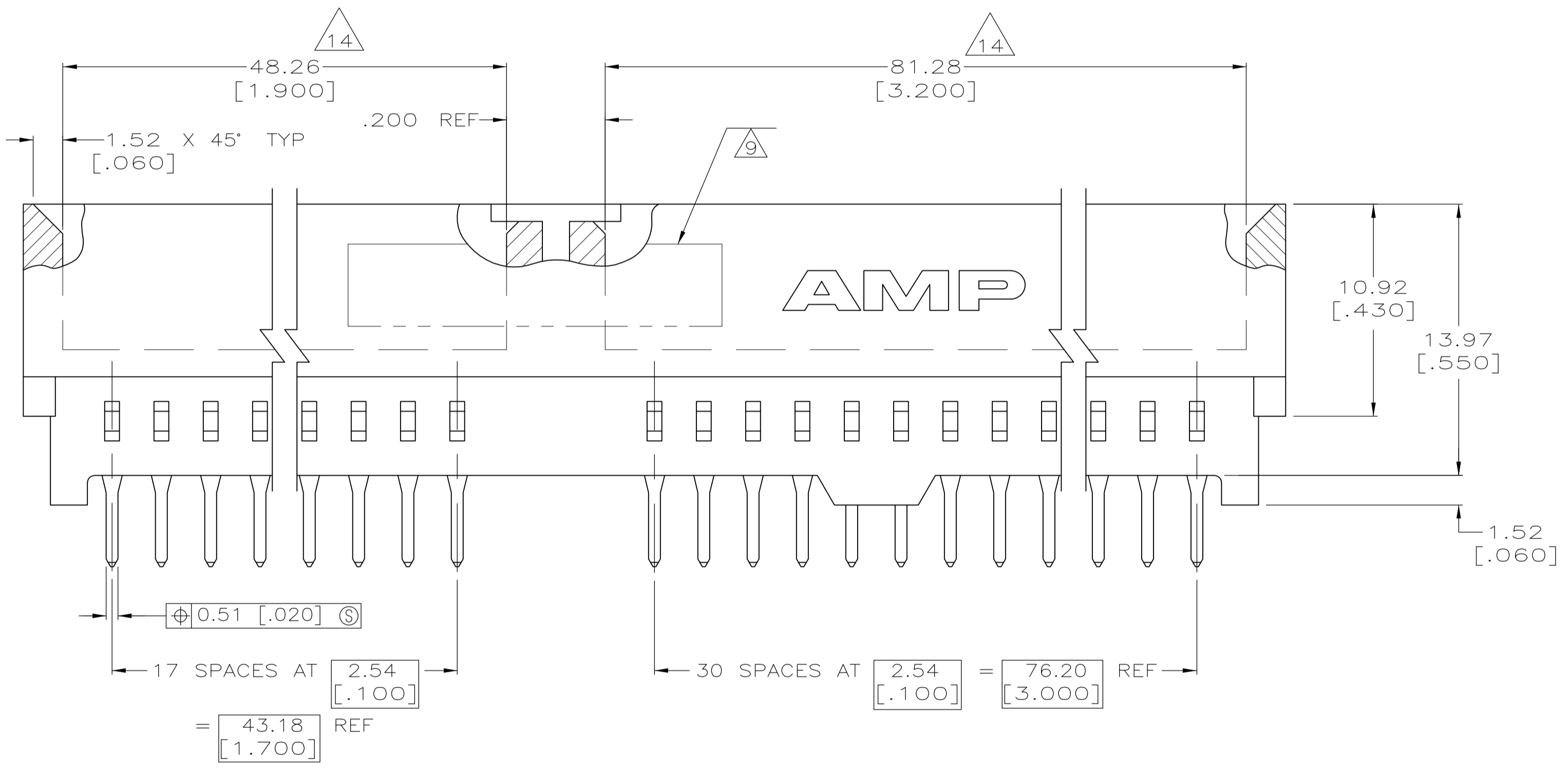
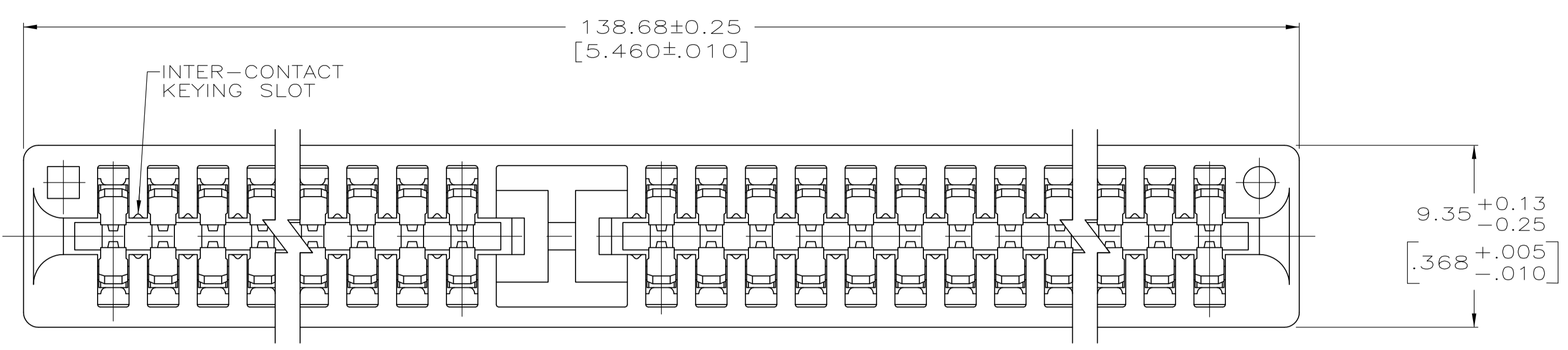

OBSOLETE	-	△	49	5176139-6
	-	△	49	5176139-5
	-	△	49	5176139-4
	5, 6, 31, 32, 41, 42, 93, 94	△	49	5176139-3
	5, 6, 31, 32, 41, 42, 93, 94	△	49	5176139-2
	5, 6, 31, 32, 41, 42, 93, 94	△	49	5176139-1
	BOARD RETENTION LOCATION	FINISH	NO OF POSN	PART NUMBER
		△3△4△8		

THIS DRAWING IS A CONTROLLED DOCUMENT.

DIMENSIONS: mm [INCHES]	TOLERANCES UNLESS OTHERWISE SPECIFIED:	0 PLC ± -	1 PLC ± -	2 PLC ± 0.13 [.005]	3 PLC ± -	4 PLC ± -	ANGLES ± °
MATERIAL	FINISH	WEIGHT	SIZE	CAGE CODE	DRAWING NO	RESTRICTED TO	
			A1	00779	5176139		

AL FRANTUM 21 OCT 04  
 AL FRANTUM 21 OCT 04  
 S FLICKINGER 10OCT2008  
 NAME: Tyco Electronics Corporation, Harrisburg, Pa 17105-3608  
 PRODUCT SPEC: 108-1248  
 APPLICATION SPEC: 114-13018  
 CUSTOMER DRAWING SCALE: 5:1 SHEET: 1 OF 2 REV: E

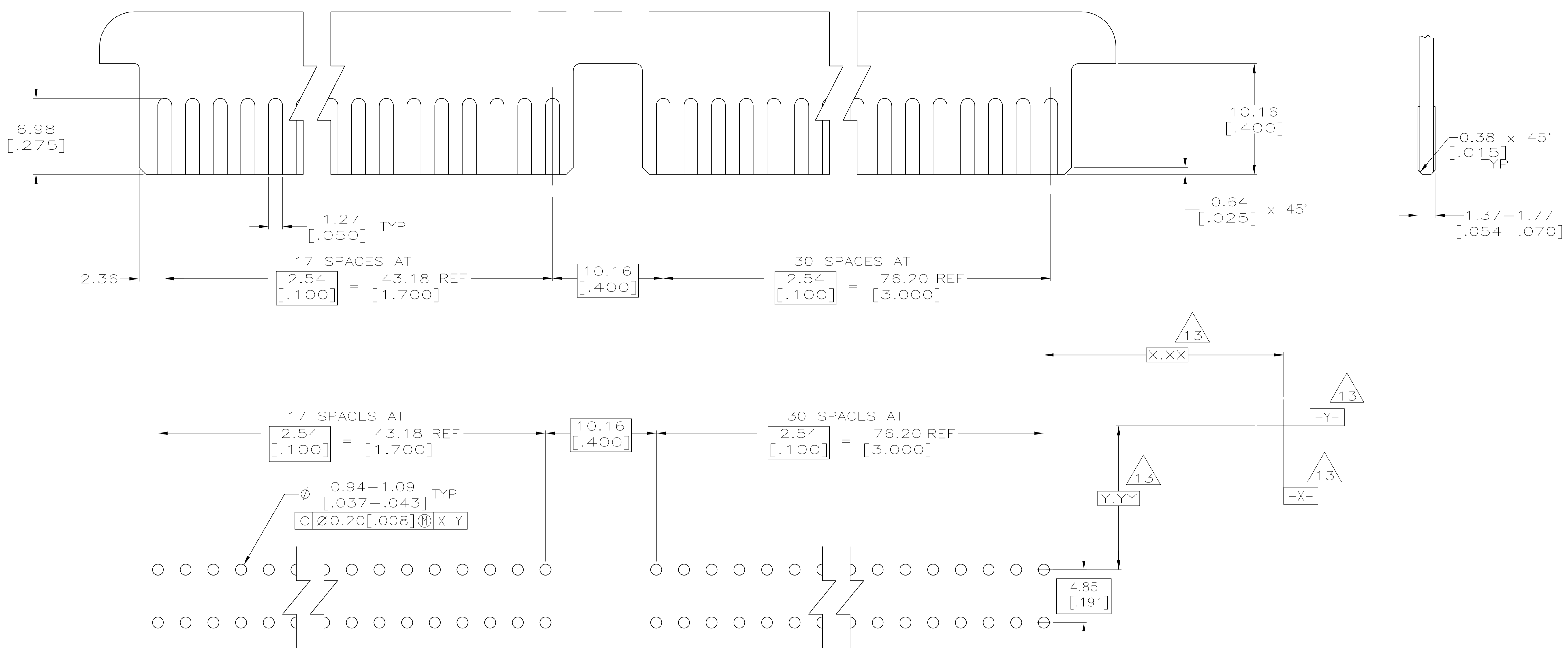

- ① HOUSING: GLASS FILLED POLYESTER; COLOR: BLACK.
- ② CONTACT: PHOSPHOR BRONZE.
- ③ NICKEL PLATE: 0.00127 [.000050] MIN - ALL OVER.
- ④ MATTE TIN PLATE: 0.00254 [.000100] MIN ON SOLDER POSTS PER 112-65-1.
- ⑤ GOLD FLASH IN CONTACT AREA.
- ⑥ GOLD PLATE: 0.00038 [.000015] MIN - CONTACT AREA.
- ⑦ GOLD PLATE: 0.00076 [.000030] MIN - CONTACT AREA.
- ⑧ NICKEL PLATE PER MIL-G-45204.  
GOLD PLATE PER QQ-N-290.
- ⑨ AMP, CSA LOGO, PART NUMBER AND DATE CODE ARE MARKED IN APPROXIMATE AREA SHOWN, EITHER SIDE.
- 10. RECOMMENDED PCB FINISHED HOLE DIA: 1.02 ± 0.08 [.040 ± .003].
- 11. THE RETENTIVE FEATURE OF THIS CONNECTOR IS DESIGNED FOR FULL SEATING IN .062 ± .008 THICK CIRCUIT BOARDS.
- ⑫ PACKAGE 20 CONNECTOR PER GANG OF TUBE.
- ⑬ DATUMS AND BASIC DIMENSIONS TO BE DETERMINED BY CUSTOMER.
- ⑭ CARD SLOT DIMENSION.

THIS DRAWING IS A CONTROLLED DOCUMENT.		DN AL FRANTUM 21 OCT 04	Tyco Electronics Corporation Harrisburg, Pa 17105-3608	
DIMENSIONS: mm [INCHES]		CHK AL FRANTUM 21 OCT 04	NAME	
TOLERANCES UNLESS OTHERWISE SPECIFIED:		APVD S FLICKINGER 10OCT2006	CONNECTOR ASSY, EDGE CARD, 2.54 [.100] CL	
0. PLC ± -	1. PLC ± -	PRODUCT SPEC	108-1248	
2. PLC ± 0.13 [.005]	3. PLC ± -	APPLICATION SPEC	114-13018	
4. PLC ± -	ANGLES ± °	SIZE	CAGE CODE	DRAWING NO
MATERIAL SEE SHEET 1	FINISH SEE SHEET 1	WEIGHT	A1 00779	5176139
CUSTOMER DRAWING		SCALE	SHEET	REV
		5:1	2 OF 2	E