



Chipsmall Limited consists of a professional team with an average of over 10 year of expertise in the distribution of electronic components. Based in Hongkong, we have already established firm and mutual-benefit business relationships with customers from,Europe,America and south Asia,supplying obsolete and hard-to-find components to meet their specific needs.

With the principle of “Quality Parts,Customers Priority,Honest Operation,and Considerate Service”,our business mainly focus on the distribution of electronic components. Line cards we deal with include Microchip,ALPS,ROHM,Xilinx,Pulse,ON,Everlight and Freescale. Main products comprise IC,Modules,Potentiometer,IC Socket,Relay,Connector.Our parts cover such applications as commercial,industrial, and automotives areas.

We are looking forward to setting up business relationship with you and hope to provide you with the best service and solution. Let us make a better world for our industry!



Contact us

Tel: +86-755-8981 8866 Fax: +86-755-8427 6832

Email & Skype: info@chipsmall.com Web: www.chipsmall.com

Address: A1208, Overseas Decoration Building, #122 Zhenhua RD., Futian, Shenzhen, China



PROTECTION PRODUCTS - RailClamp®
Description

The RailClamp® series is a family of ultra low capacitance TVS arrays designed to protect high speed data interfaces. This series has been specifically designed to protect sensitive components which are connected to high-speed data and transmission lines from overvoltage caused by **ESD** (electrostatic discharge), **CDE** (Cable Discharge Events), and **EFT** (electrical fast transients). They are designed for use in applications where board space is at a premium. Each device requires less than 1.5mm² of PCB area and will protect up to three high speed data lines.

The monolithic design incorporates surge rated, low capacitance steering diodes and a TVS diode in a single package. Each line has a maximum capacitance of 0.5pF to ground. The capacitance of each line is well matched for constant signal balance. A connection to the TVS is provided for protection of an external voltage bus, such as those found in USB applications. This device is optimized for ESD protection of portable electronics. They may be used to meet the ESD immunity requirements of IEC 61000-4-2, Level 4 ($\pm 15\text{kV}$ air, $\pm 8\text{kV}$ contact discharge).

The RClamp0503N is in a 6-pin, RoHS/WEEE compliant, SLP1510N6 package. It measures 1.45 x 1.0 x 0.58mm. The small package makes it ideal for use in portable electronics such as cell phones, laptops, and digital still cameras.

Features

- ◆ ESD protection for high-speed data lines to **IEC 61000-4-2 (ESD) $\pm 15\text{kV}$ (air), $\pm 8\text{kV}$ (contact)**
- ◆ **IEC 61000-4-4 (EFT) 40A (5/50ns)**
- ◆ Array of surge rated diodes with internal TVS Diode
- ◆ Small package saves board space
- ◆ Protects three I/O lines and a power line
- ◆ Low capacitance: **0.5pF** maximum
- ◆ Low clamping voltage
- ◆ Solid-state silicon-avalanche technology

Mechanical Characteristics

- ◆ SLP1510N6 Package
- ◆ RoHS/WEEE Compliant
- ◆ Nominal Dimensions: 1.45 x 1.0 x 0.58 mm
- ◆ Lead Pitch: 0.5mm
- ◆ Lead Finish: NiPdAu
- ◆ Marking : Marking Code
- ◆ Packaging : Tape and Reel

Applications

- ◆ USB OTG
- ◆ MMC Port
- ◆ Serial ATA
- ◆ Video Port
- ◆ SIM Port
- ◆ PCI Express

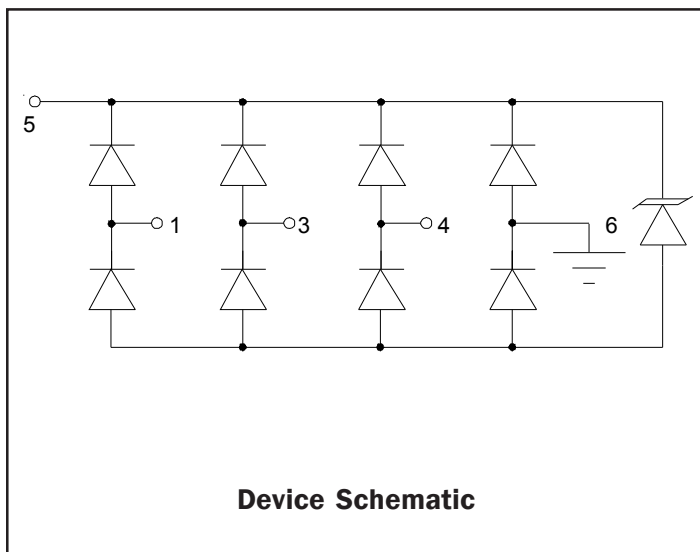
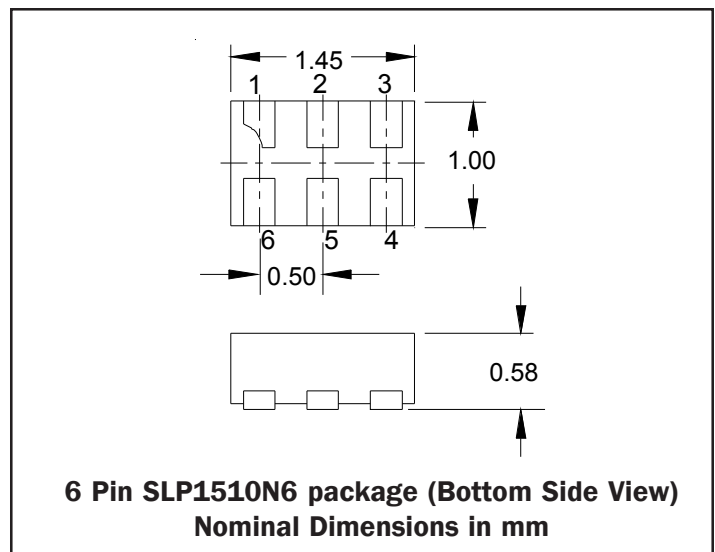
Circuit Diagram

Package Dimensions

PROTECTION PRODUCTS
Absolute Maximum Rating

Rating	Symbol	Value	Units
Peak Pulse Power (tp = 8/20μs)	P_{pk}	100	Watts
Peak Pulse Current (tp = 8/20μs)	I_{pp}	3	A
ESD per IEC 61000-4-2 (Air) ESD per IEC 61000-4-2 (Contact)	V_{ESD}	±15 ±8	kV
Operating Temperature	T_J	-55 to +125	°C
Storage Temperature	T_{STG}	-55 to +150	°C

Electrical Characteristics (T = 25°C)

RClamp0503N						
Parameter	Symbol	Conditions	Minimum	Typical	Maximum	Units
Reverse Stand-Off Voltage	V_{RWM}	Pin 5 to GND			6.5	V
Reverse Breakdown Voltage	V_{BR}	$I_t = 1mA$ Pin 5 to GND	7	9.5	12	V
Reverse Leakage Current	I_R	$V_{RWM} = 6.5V, T=25°C$ Pin 5 to GND			1	μA
Forward Voltage	V_F	$I_f = 15mA$ Any I/O to pin 5		0.9	1.2	V
Clamping Voltage	V_C	$I_{pp} = 1A, tp = 8/20μs$ Any I/O pin to Ground			16.5	V
Clamping Voltage	V_C	$I_{pp} = 3A, tp = 8/20μs$ Any I/O pin to Ground			30	V
Junction Capacitance	C_J	$V_R = 0V, f = 1MHz$ Any I/O pin to Ground		0.3	0.5	pF
		$V_R = 0V, f = 1MHz$ Between I/O pins		0.3	0.5	pF

PROTECTION PRODUCTS

Typical Characteristics

Non-Repetitive Peak Pulse Power vs. Pulse Time

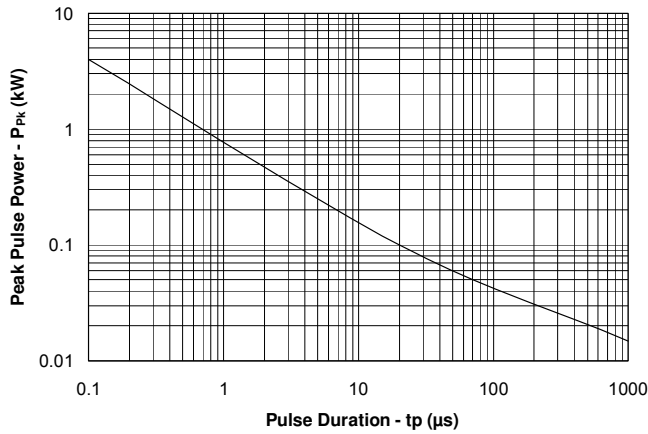

Power Derating Curve

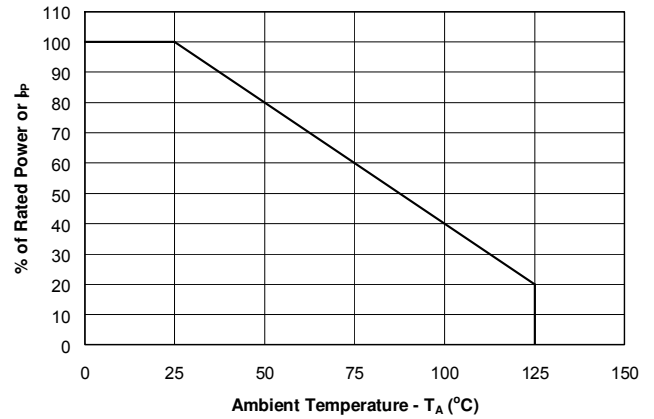

Clamping Voltage vs. Peak Pulse Current
I/O to Gnd - Pin 1, 3, 4 to Gnd at Pin 6

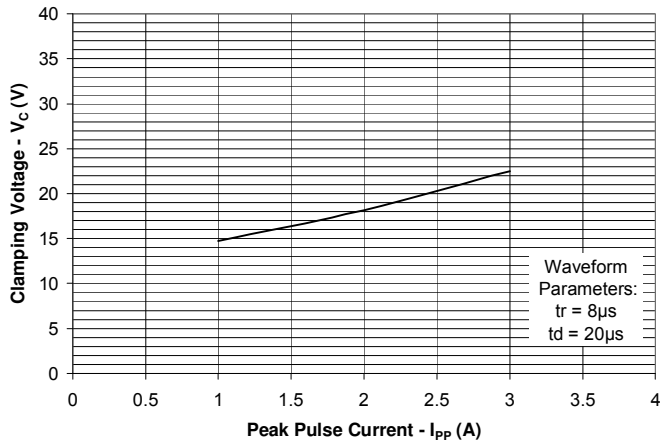

Forward Voltage vs. Forward Current
Pin 1,3,4 or 6 to Pin 5

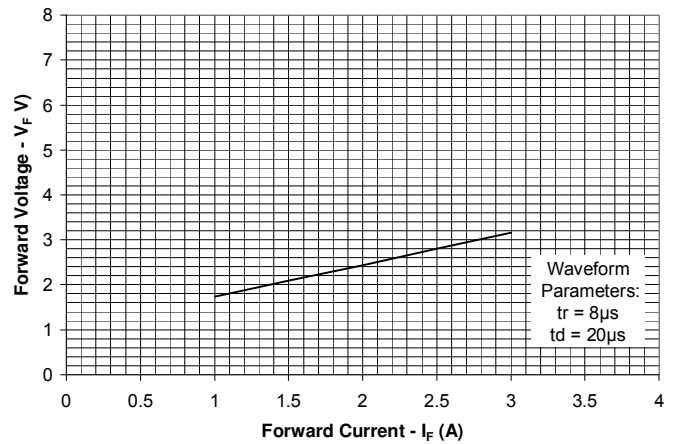

Normalize Capacitance vs. Reverse Voltage
I/O to Gnd - Pin 1, 3, 4 to Gnd at Pin 6

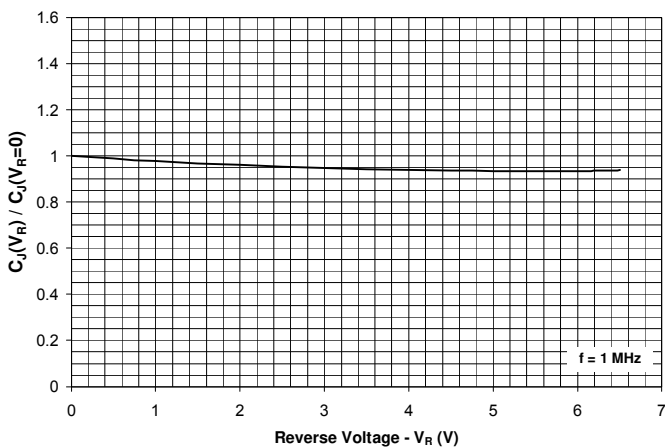

PROTECTION PRODUCTS

Applications Information

Device Connection Options for Protection of three High-Speed Data Lines

Data line inputs are normally connected at pins 1, 3, & 4 with pin 6 connected to ground. Note that the circuit at the ground pin is identical to the circuit at each data input/output pin. This is done to further reduce capacitance. The connection to ground should be made directly to a ground plane. The path length should also be kept as short as possible to minimize parasitic inductance. Pin 5 can be connected to Vcc biased or left not connected depending upon the application.

Figure 1- Pin Configuration & Circuit Diagram

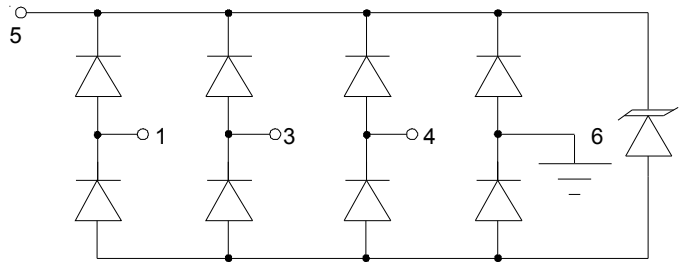

Protecting USB OTG Interfaces

The USB OTG interface consists of Data (D- and D+) lines, ID and a 5.25V voltage bus. Since these pins are part of the connector, they are vulnerable to ESD and cable discharge events. The RClamp0503N is designed to protect D-, D+, and ID pins of USB OTG connections. Each device will protect one USB OTG port. When the voltage on the data lines exceeds the bus voltage (plus one diode drop), the internal rectifiers are forward biased conducting the transient current away from the protected controller chip. The TVS diode directs the surge to ground. For Vbus protection, an additional single line TVS, such as uClamp0501P, should be added.

Figure 2 - USB OTG Protection

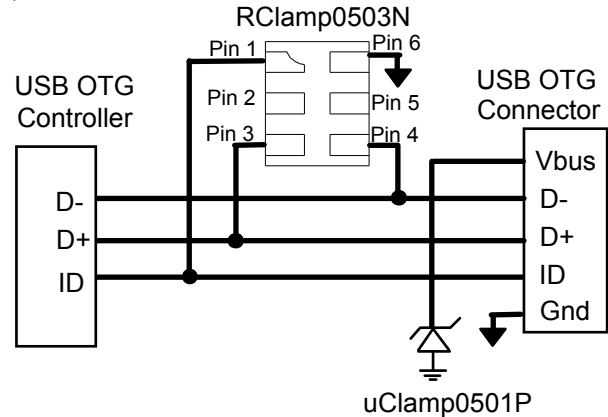

PROTECTION PRODUCTS

Applications Information - Spice Model

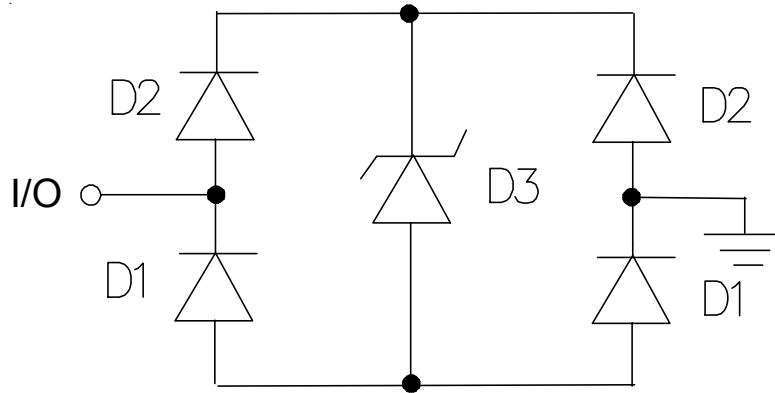
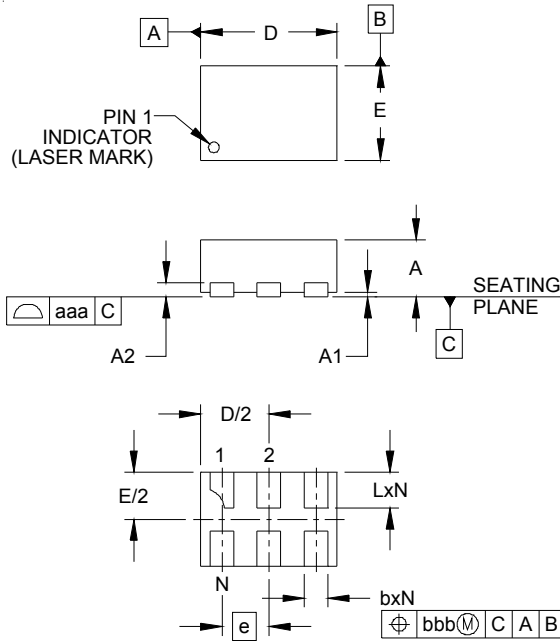

Figure 3 - RClamp0503N Spice Model

RClamp0503N Spice Parameters				
Parameter	Unit	D1 (LCRD)	D2 (LCRD)	D3 (TVS)
IS	Amp	1.0E-20	1.0E-20	2E-12
BV	Volt	100	100	9
VJ	Volt	0.7	0.7	0.6
RS	Ohm	0.458	1.0	2.6
IBV	Amp	1.0 E-3	1.0 E-3	1.0 E-3
CJO	Farad	0.4E-12	0.4E-12	56E-12
TT	sec	2.541E-9	2.541E-9	2.541E-9
M	--	0.058	0.058	0.23
N	--	1.1	1.1	1.1
EG	eV	1.11	1.11	1.11

PROTECTION PRODUCTS

Outline Drawing - SLP1510N6



DIM	INCHES		MILLIMETERS			
	MIN	NOM	MAX	MIN	NOM	MAX
A	.020	.023	.026	0.50	0.58	0.65
A1	0.00	.001	.002	0.00	0.03	0.05
A2		(.005)			(0.13)	
b	.008	.010	.012	0.20	0.25	0.30
D	.053	.057	.061	1.35	1.45	1.55
E	.035	.039	.043	0.90	1.00	1.10
e	.020 BSC		0.50 BSC			
L	.012	.015	.017	0.30	0.38	0.425
N	6		6			
aaa	.003		0.08			
bbb	.004		0.10			

- NOTES:
1. CONTROLLING DIMENSIONS ARE IN MILLIMETERS (ANGLES IN DEGREES).
 2. COPLANARITY APPLIES TO THE EXPOSED PAD AS WELL AS THE TERMINALS.

Land Pattern - SLP1510N6

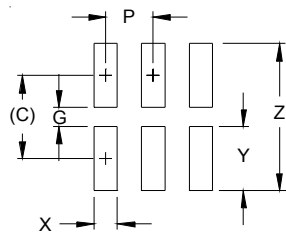

DIM	DIMENSIONS	
	INCHES	MILLIMETERS
C	(.034)	(0.875)
G	.008	0.20
P	.020	0.50
X	.010	0.25
Y	.027	0.675
Z	.061	1.55

- NOTES:
1. THIS LAND PATTERN IS FOR REFERENCE PURPOSES ONLY. CONSULT YOUR MANUFACTURING GROUP TO ENSURE YOUR COMPANY'S MANUFACTURING GUIDELINES ARE MET.

PROTECTION PRODUCTS

Marking Codes

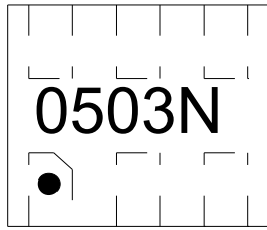

Ordering Information

Part Number	Qty per Reel	Reel Size
RClamp0503N.TCT	3,000	7 Inch

RClamp and RClamp are marks of Semtech Corporation

Tape and Reel Specification

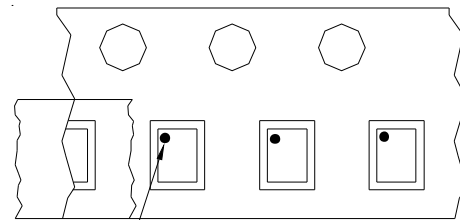
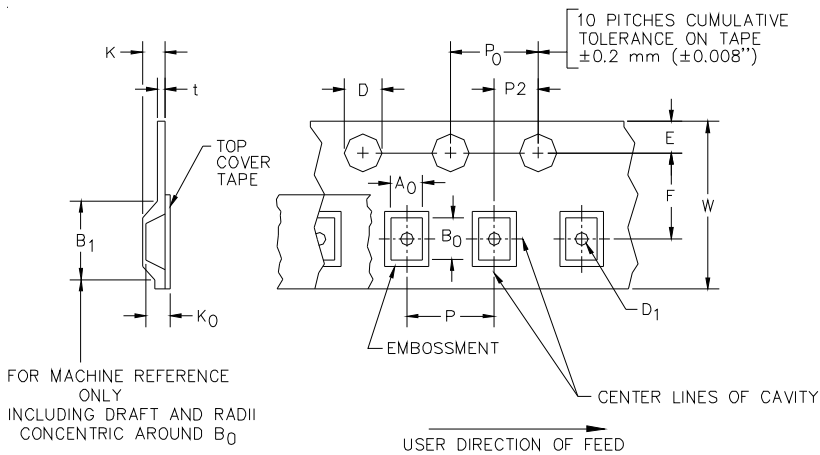

Device Orientation in Tape

A0	B0	K0
1.24±0.10mm	1.70±0.10mm	0.76±0.10mm

Tape Width	B, (Max)	D	D1	E	F	K (MAX)	P	P0	P2	T(MAX)	W
8 mm	4.2 mm (.165)	1.5 + 0.1 mm - 0.0 mm (0.59 +.005 -.000)	0.8 mm ±0.05 (.031)	1.750±.10 mm (.069±.004)	3.5±0.05 mm (.138±.002)	2.4 mm (.094)	4.0±0.1 mm (.157±.00- 4)	4.0±0.1 mm (.157±.00- 4)	2.0±0.05m- m (.079±.002)	0.4 mm (.016)	8.0 mm + 0.3 mm - 0.1 mm (.312±.012)

Contact Information

Semtech Corporation
 Protection Products Division
 200 Flynn Road, Camarillo, CA 93012
 Phone: (805)498-2111 FAX (805)498-3804