



Chipsmall Limited consists of a professional team with an average of over 10 year of expertise in the distribution of electronic components. Based in Hongkong, we have already established firm and mutual-benefit business relationships with customers from,Europe,America and south Asia,supplying obsolete and hard-to-find components to meet their specific needs.

With the principle of "Quality Parts,Customers Priority,Honest Operation,and Considerate Service",our business mainly focus on the distribution of electronic components. Line cards we deal with include Microchip,ALPS,ROHM,Xilinx,Pulse,ON,Everlight and Freescale. Main products comprise IC,Modules,Potentiometer,IC Socket,Relay,Connector.Our parts cover such applications as commercial,industrial, and automotives areas.

We are looking forward to setting up business relationship with you and hope to provide you with the best service and solution. Let us make a better world for our industry!



## Contact us

Tel: +86-755-8981 8866 Fax: +86-755-8427 6832

Email & Skype: info@chipsmall.com Web: www.chipsmall.com

Address: A1208, Overseas Decoration Building, #122 Zhenhua RD., Futian, Shenzhen, China



#### PROTECTION PRODUCTS - RailClamp®

#### Description

RailClamp® TVS diode arrays are specifically designed to protect sensitive components which are connected to high-speed data and transmission lines from over-voltage caused by **ESD** (electrostatic discharge), **CDE** (Cable Discharge Events), and **EFT** (electrical fast transients).

The RClamp®0542T has a typical capacitance of only 0.25pF between I/O pins. This allows it to be used on circuits operating in excess of 3GHz without signal attenuation. These devices are constructed using Semtech's proprietary RailClamp process technology. This technology yields superior electrical characteristics including reduced leakage current (IR), a key requirement for high-speed interfaces. As such, the RClamp0542T has a maximum IR of only 50nA at 5 volts.

The RClamp0542T is in a 6-pin SLP1610P4T package. It measures 1.6 x 1.0 x 0.4mm. The leads are spaced at a pitch of 0.5mm and are finished with lead-free NiPdAu. They are designed for easy PCB layout by allowing the traces to run straight through the device. They may be used to meet the ESD immunity requirements of IEC 61000-4-2. Each device is designed to protect two lines (one differential pair). The combination of small size, low capacitance, low leakage current, and high level of ESD protection makes them a flexible solution for protection of next generation interfaces including 10Gigabit Ethernet, HDMI 1.4, and USB 3.0.

#### Features

- ◆ Transient protection for high-speed data lines to **IEC 61000-4-2 (ESD) ±18kV (air), ±12kV (contact) IEC 61000-4-4 (EFT) 40A (5/50ns)**
- ◆ Array of surge rated diodes with internal TVS Diode
- ◆ Small package saves board space
- ◆ Protects up to 6-Lines operating at 5V
- ◆ Low capacitance: **0.25pF** typical (I/O to I/O)
- ◆ No insertion loss to **3.0GHz**
- ◆ Low leakage current
- ◆ Low clamping voltage
- ◆ Innovative package for easy pcb layout
- ◆ Solid-state silicon-avalanche technology

#### Mechanical Characteristics

- ◆ SLP1610P4T 6-pin package
- ◆ Pb-Free, Halogen Free, RoHS/WEEE Compliant
- ◆ Nominal Dimensions: 1.6 x 1.0 x 0.40 mm
- ◆ Lead Finish: NiPdAu
- ◆ Molding compound flammability rating: UL 94V-0
- ◆ Marking: Marking code
- ◆ Packaging: Tape and Reel

#### Applications

- ◆ 10GBASE-T Ethernet
- ◆ 10/100/1000 Ethernet
- ◆ SATA
- ◆ USB 3.0
- ◆ HDMI 1.4

#### Circuit Diagram

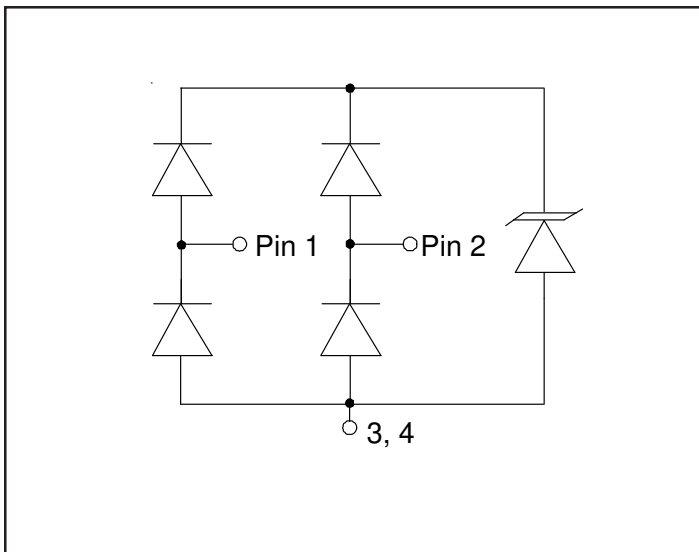

#### PIN Configuration

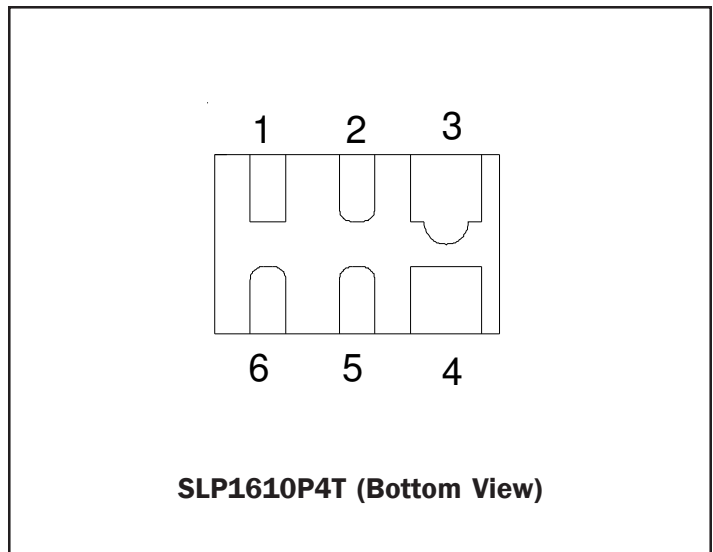

**PROTECTION PRODUCTS**
**Absolute Maximum Rating**

Rating	Symbol	Value	Units
Peak Pulse Power (tp = 8/20μs)	$P_{pk}$	75	Watts
Peak Pulse Current (tp = 8/20μs)	$I_{pp}$	5	A
ESD per IEC 61000-4-2 (Air) ESD per IEC 61000-4-2 (Contact)	$V_{ESD}$	+/- 18 +/- 12	kV
Operating Temperature	$T_J$	-55 to +125	°C
Storage Temperature	$T_{STG}$	-55 to +150	°C

**Electrical Characteristics (T = 25°C)**

Parameter	Symbol	Conditions	Minimum	Typical	Maximum	Units
Reverse Stand-Off Voltage	$V_{RWM}$	Any I/O to GND			5	V
Reverse Breakdown Voltage	$V_{BR}$	$I_t = 1mA$ , Any I/O to GND	6.5	8	11	V
Reverse Leakage Current	$I_R$	$V_{RWM} = 5.0V$ , Any I/O to GND		0.005	0.050	μA
Forward Voltage	$V_F$	$I_f = 15mA$ Any I/O to GND	0.6		1.2	V
Clamping Voltage	$V_C$	$I_{pp} = 1A$ , tp = 8/20μs Any I/O to GND			12	V
Clamping Voltage	$V_C$	$I_{pp} = 5A$ , tp = 8/20μs Any I/O to GND			15	V
Junction Capacitance	$C_j$	$V_R = 0V$ , f = 1MHz, Any I/O to GND		0.45	0.60	pF
		$V_R = 0V$ , f = 1MHz, Between I/O pins		0.25	0.4	pF

## PROTECTION PRODUCTS

### Typical Characteristics

#### Non-Repetitive Peak Pulse Power vs. Pulse Time

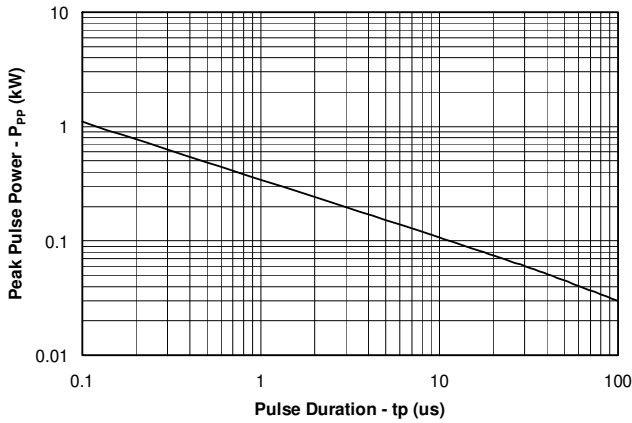

#### Pulse Waveform

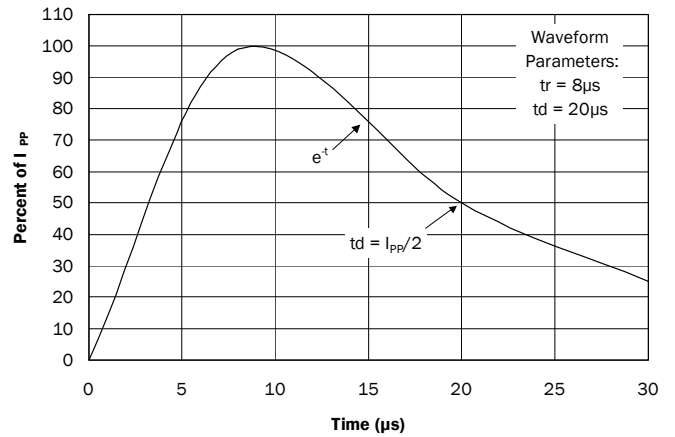

#### Clamping Voltage vs. Peak Pulse Current

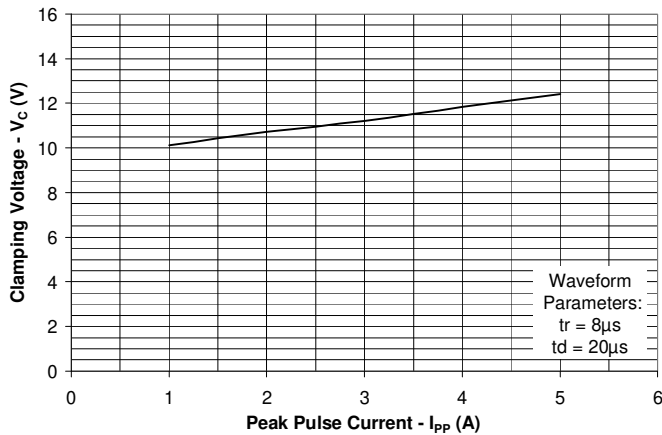

#### Normalized Capacitance vs. Reverse Voltage

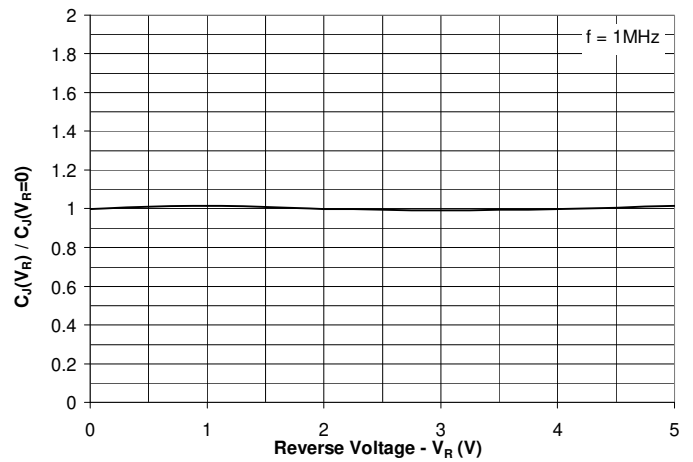

#### ESD Clamping (Any I/O to GND) (+8kV Contact per IEC 61000-4-2)

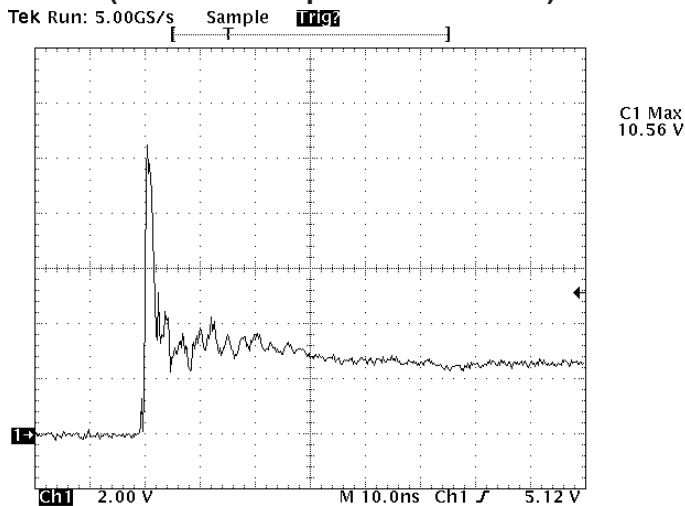

Note: Data is taken with a 10x attenuator

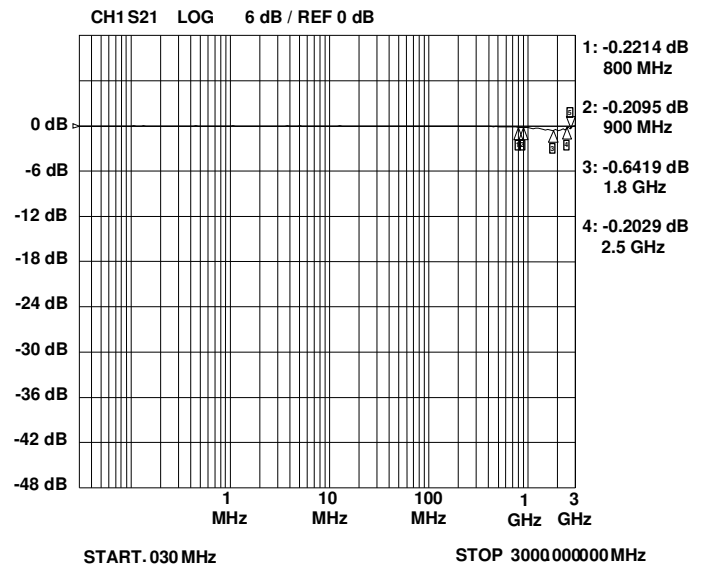
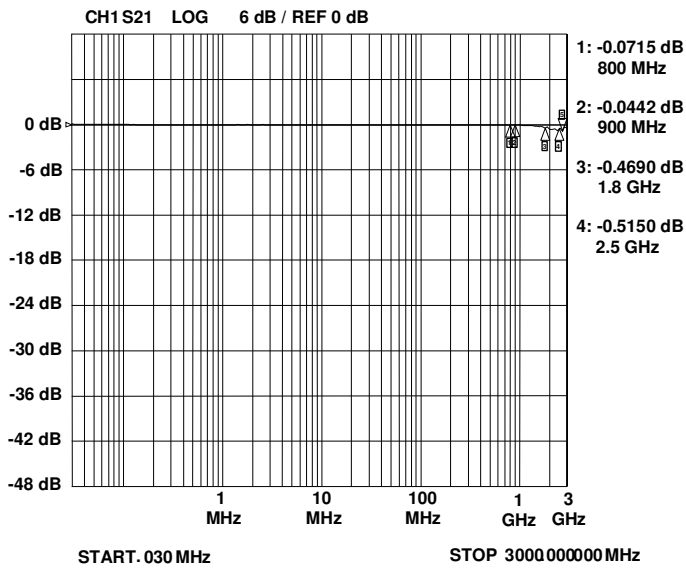
**PROTECTION PRODUCTS**
**Typical Characteristics**
**Insertion Loss S21 - I/O to I/O**
**Insertion Loss S21 - I/O to GND**

## PROTECTION PRODUCTS

### Applications Information

#### Device Connection and Layout for Protecting 2 High-Speed Lines

Selecting the correct component for ESD protection of high-speed circuits is critical. Not only does the designer have to consider device characteristics such as clamping voltage and junction capacitance, but package layout as well. A carefully chosen package can mean the difference between a layout optimized for high speed signals and one that requires uneven trace routing, vias, and transmission line stubs. The RClamp0542T is optimized for use on high-speed lines. It utilizes a flow through design that allows traces to be routed uninterrupted through the device. This virtually eliminates impedance mismatches and stubs in the high speed signal path. It also allows traces to remain tightly coupled, reducing EMI interference. Data lines enter the device at pins 1 and 2 and exit the devices at pins 5 and 6. Traces are kept continuous and unbroken. Ground connection is made at pins 3 and 4. The location and size of the pins simplifies connection to the ground plane using multiple vias. Parasitic inductance is thus reduced enhancing ESD clamping performance.

#### Protection USB 3.0 Interfaces

USB 3.0 expands the USB interface to include two superspeed differential pairs. These pairs are capable of transmitting data up to 5Gbps or almost 10 times faster than USB 2.0 high speed lines. In order to maintain backwards compatibility, the USB connector still retains the high speed D+ and D- differential pair and one VBus line. There are several advantages in using the RClamp0542T to protect the USB 3.0 superspeed lines. First, as mentioned above the flow through design of the package minimizes any discontinuity in the signal path. Also, using one package per signal pair eliminates cross talk between the transmit and receive pairs. Electrically, the low leakage current (5nA typical) will not affect the line termination impedance. Finally, it presents a typical loading capacitance of <0.5pF between I/O and ground. In some cases another device may be better suited for use on the high speed lines. For example, in mobile applications, RClamp1624T or RClamp3624T are better solutions for the high speed lines since they integrate high voltage protection for the VBus lines. Some USB 3.0 protection examples are shown in Figure 4 and 5.

Figure 1- Pin Configuration

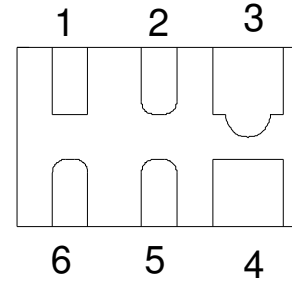

Pin	Identification
1 - 2	Input Lines
5 - 6	Output Lines (No Internal Connection)
3 - 4	Ground

Figure 2 - Circuit Diagram

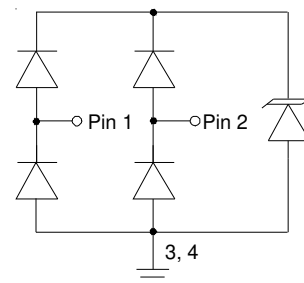
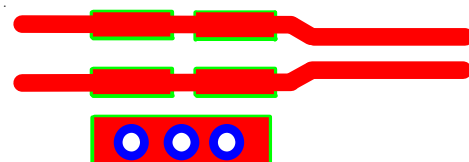
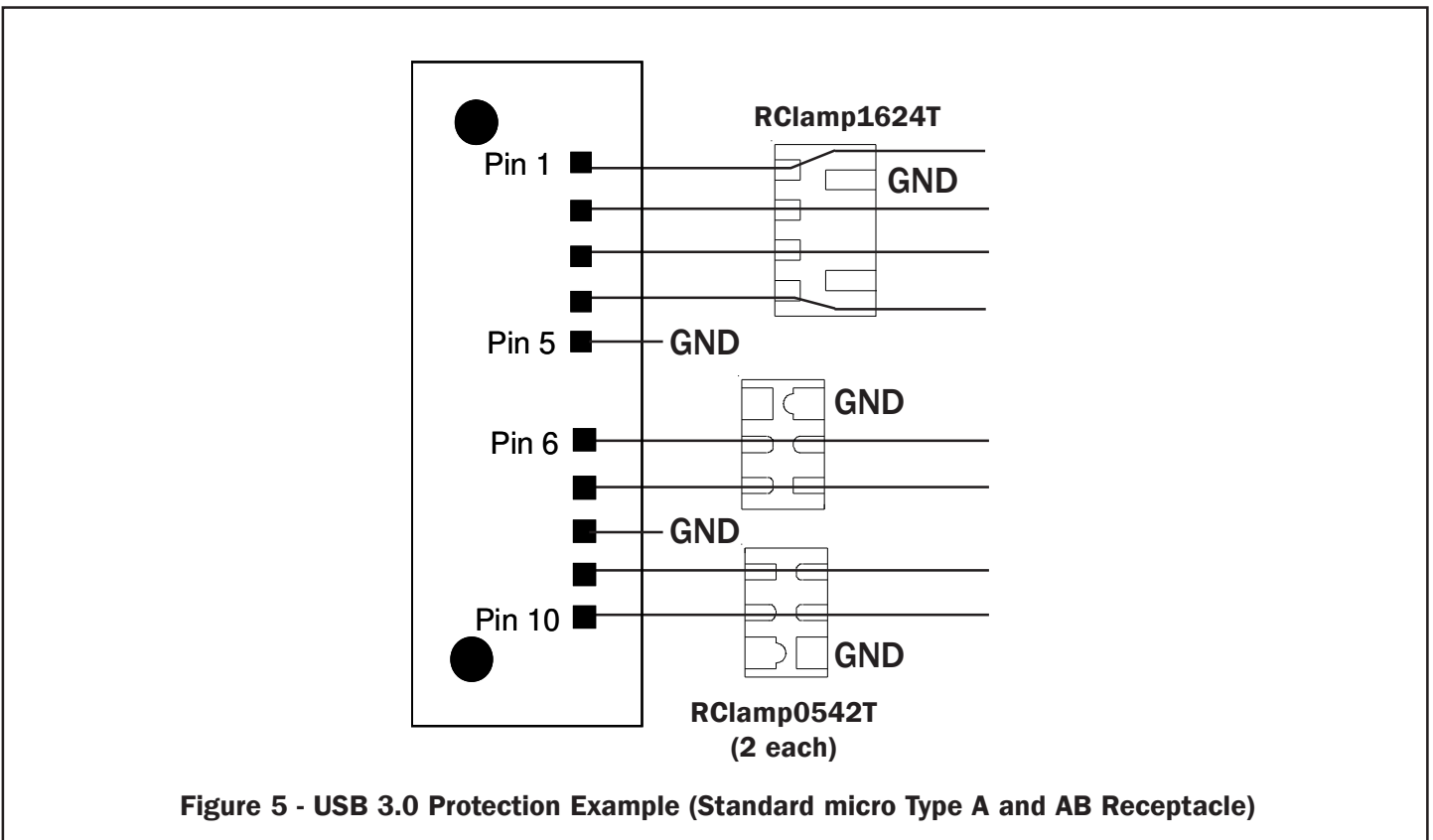
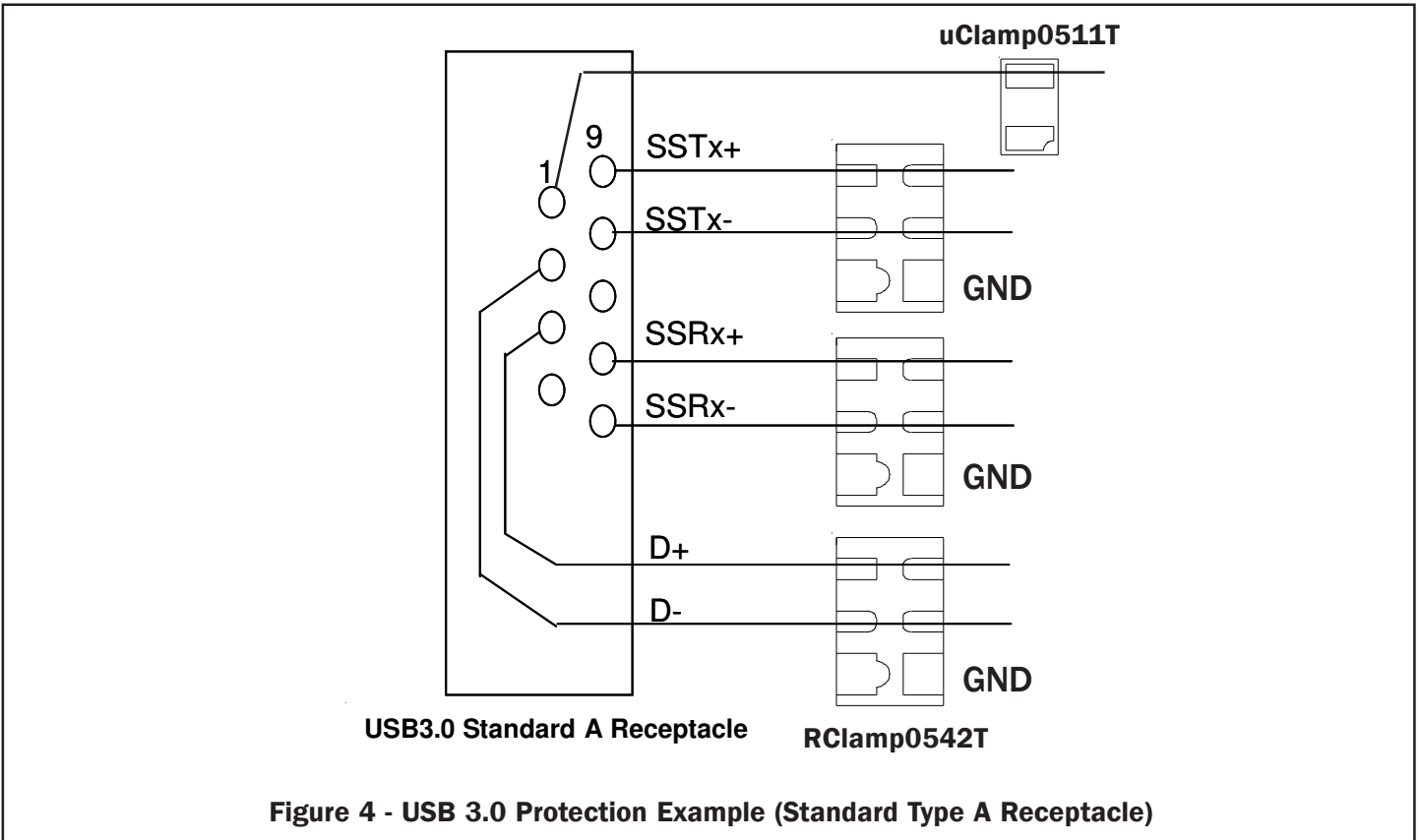

Figure 3 - Layout Example





## PROTECTION PRODUCTS

### Applications Information

#### 10GbaseT Ethernet Protection

When designing Ethernet protection, the entire system must be considered. An Ethernet port includes interface magnetics in the form of transformers and common mode chokes. Transformers and chokes can be discrete components, but integrated solutions that include the RJ-45 connector, resistors, capacitors, and protection are also available. In either case, the transformer will provide a high level of common mode isolation to external voltages, but no protection for metallic (line-to-line) surges. During a metallic transient event, current will flow into one line, through the transformer and back to the source. As the current flows, it charges the windings of the transformer on the line side. Once the surge is removed, the windings on the line side will stop charging and will transfer its stored energy to the IC side where the PHY is located. The magnitude and duration of the surge is attenuated by the inductance

of the magnetics. The amount of attenuation will vary by vendor and configuration of the magnetics. It is this transferred energy that must be clamped by the protection circuitry.

A typical protection scheme which utilizes the RClamp0542T is shown in Figure 5. One device is placed across each line pair and is located on the PHY side of the transformer as close to the magnetics as possible. This is done to minimize parasitic inductance and improve clamping performance. Data lines are routed through the device minimizing any discontinuity in the signal path. The ground pins of the RClamp0542T are left unconnected. When connected in this configuration, the RClamp0542T presents a typical capacitance of less than 0.3pF between each line pair.

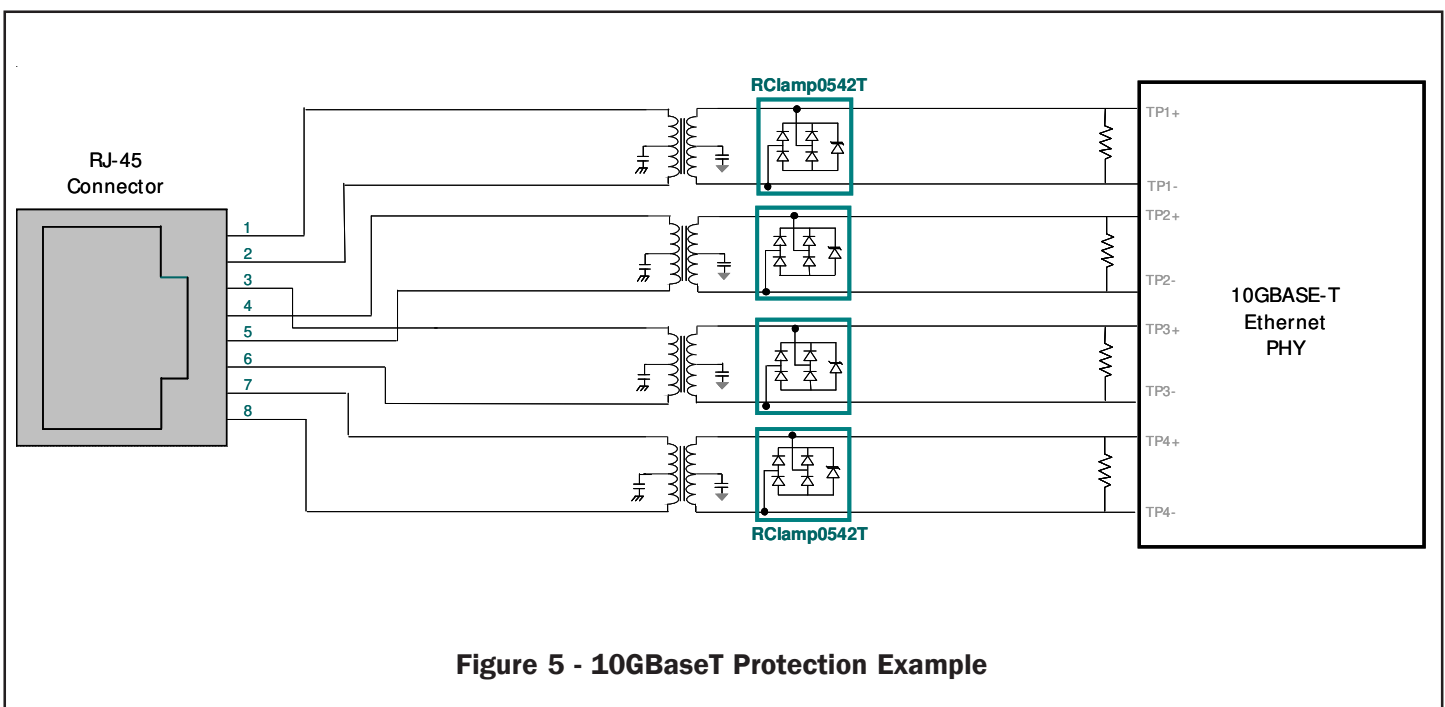
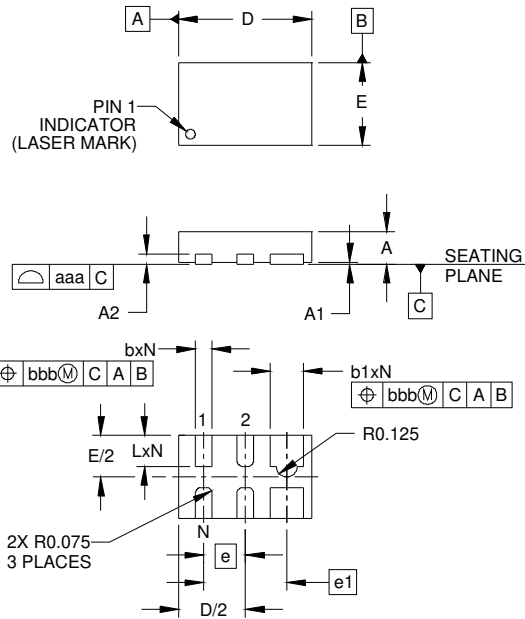

Figure 5 - 10GBaseT Protection Example



PROTECTION PRODUCTS

Outline Drawing - SLP1610P4T



DIM	INCHES			MILLIMETERS		
	MIN	NOM	MAX	MIN	NOM	MAX
A	.015	.016	.017	0.37	0.40	0.43
A1	0.00	.001	.002	0.00	0.03	0.05
A2	(.005)			(0.13)		
b	.006	.008	.010	0.15	0.20	0.25
b1	.014	.016	.018	0.35	0.40	0.45
D	.059	.063	.067	1.50	1.60	1.70
E	.035	.039	.043	0.90	1.00	1.10
e	.020 BSC			0.50 BSC		
e1	.039 BSC			1.00 BSC		
L	.012	.015	.017	0.30	0.38	0.43
N	4			4		
aaa	.003			0.08		
bbb	.004			0.10		

NOTES:  
1. CONTROLLING DIMENSIONS ARE IN MILLIMETERS (ANGLES IN DEGREES).

Land Pattern - SLP1610P4T

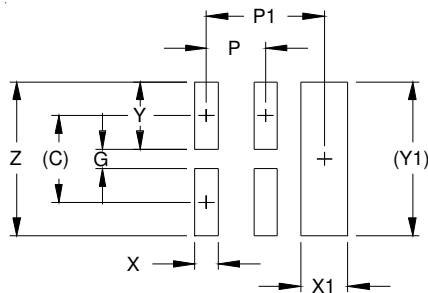

DIM	DIMENSIONS	
	INCHES	MILLIMETERS
C	(.034)	(0.875)
G	.008	0.20
P	.020	0.50
P1	.039	1.00
X	.008	0.20
X1	.016	0.40
Y	.027	0.675
Y1	(.061)	(1.55)
Z	.061	1.55

NOTES:  
1. CONTROLLING DIMENSIONS ARE IN MILLIMETERS (ANGLES IN DEGREES).  
2. THIS LAND PATTERN IS FOR REFERENCE PURPOSES ONLY.  
CONSULT YOUR MANUFACTURING GROUP TO ENSURE YOUR COMPANY'S MANUFACTURING GUIDELINES ARE MET.

## PROTECTION PRODUCTS

### Marking

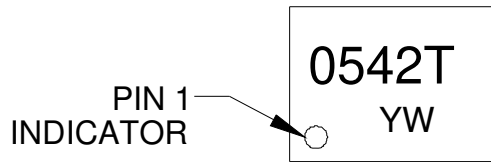

### Ordering Information

Part Number	Lead Finish	Qty per Reel	Reel Size
RClamp0542T.TCT	Pb Free	3,000	7 Inch

RailClamp and RClamp are marks of Semtech Corporation

YW = Date Code

### Tape and Reel Specification

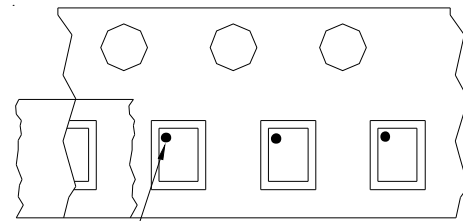
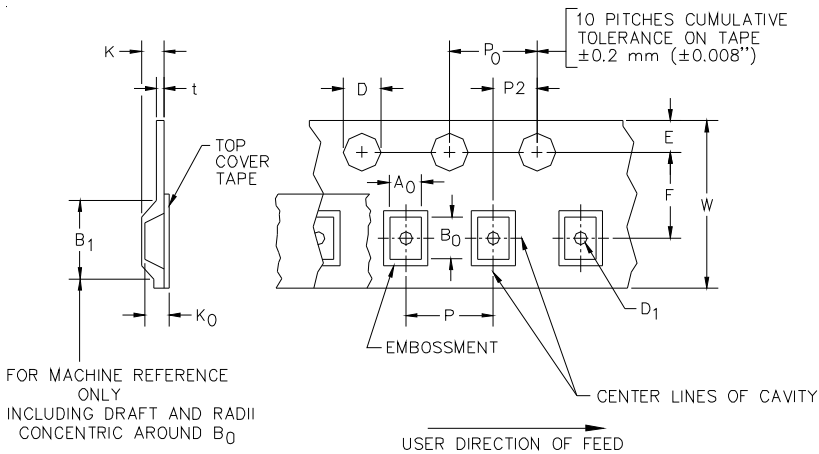

Pin 1 Location

User Direction of feed

**Device Orientation in Tape**

**Pin 1 in upper left towards sprocket holes**

A0	B0	K0
1.30 +/-0.05 mm	1.75 +/-0.05 mm	0.70 +/-0.05 mm

Tape Width	B, (Max)	D	D1	E	F	K (MAX)	P	P0	P2	T(MAX)	W
8 mm	4.2 mm	1.5 + 0.1 mm - 0.0 mm )	0.5 mm ±0.05	1.750±.10 mm	3.5±0.05 mm	2.4 mm	4.0±0.1 mm	4.0±0.1 mm	2.0±0.05 mm	0.4 mm	8.0 mm + 0.3 mm - 0.1 mm

### Contact Information

Semtech Corporation  
 Protection Products Division  
 200 Flynn Rd., Camarillo, CA 93012  
 Phone: (805)498-2111 FAX (805)498-3804