



Chipsmall Limited consists of a professional team with an average of over 10 year of expertise in the distribution of electronic components. Based in Hongkong, we have already established firm and mutual-benefit business relationships with customers from,Europe,America and south Asia,supplying obsolete and hard-to-find components to meet their specific needs.

With the principle of “Quality Parts,Customers Priority,Honest Operation,and Considerate Service”,our business mainly focus on the distribution of electronic components. Line cards we deal with include Microchip,ALPS,ROHM,Xilinx,Pulse,ON,Everlight and Freescale. Main products comprise IC,Modules,Potentiometer,IC Socket,Relay,Connector.Our parts cover such applications as commercial,industrial, and automotives areas.

We are looking forward to setting up business relationship with you and hope to provide you with the best service and solution. Let us make a better world for our industry!



Contact us

Tel: +86-755-8981 8866 Fax: +86-755-8427 6832

Email & Skype: info@chipsmall.com Web: www.chipsmall.com

Address: A1208, Overseas Decoration Building, #122 Zhenhua RD., Futian, Shenzhen, China



PROTECTION PRODUCTS - RailClamp®

Description

RailClamp® TVS diodes are ultra low capacitance devices designed to protect sensitive electronics from damage or latch-up due to ESD, EFT, and EOS. They are designed for use on high speed ports in applications such as cell phones, notebook computers, and other portable electronics. These devices offer desirable characteristics for board level protection including fast response time, low operating and clamping voltage, and no device degradation.

RClamp®3331Y features extremely good ESD protection characteristics including a low typical dynamic resistance of 0.27 Ohms, low peak ESD clamping voltage, and high ESD withstand voltage (+/-18kV contact per IEC 61000-4-2). Low typical capacitance (0.35pF at VR=0V) allows the RClamp3331Z to be used in applications operating in excess of 5GHz without appreciable signal attenuation. Each device will protect one high speed data line operating at 3.3 Volts.

RClamp3331Y is in a 2-pin SLP0603P2X3E package measuring 0.6 x 0.3 mm with a nominal height of 0.25mm. Leads are finished with lead-free NiAu. The small package gives the designer the flexibility to protect single lines in applications where arrays are not practical. The combination of low peak ESD clamping, low dynamic resistance, and low capacitance makes this device suitable for applications such as USB 3.0, MIPI and V-By-One interfaces in portable devices.

Features

- ◆ High ESD withstand Voltage: +/-**18kV** (Contact/Air) per **IEC 61000-4-2**
- ◆ Able to withstand over 1000 ESD strikes per IEC 61000-4-2 Level 4
- ◆ Ultra-small **0201 package**
- ◆ Protects one high speed data line
- ◆ Working voltage: +/- 3.3V
- ◆ Low capacitance: **0.35pF typical**
- ◆ Extremely low dynamic resistance: **0.27 Ohms (Typ)**
- ◆ Low ESD clamping voltage
- ◆ Solid-state silicon-avalanche technology

Mechanical Characteristics

- ◆ SLP0603P2X3E Package
- ◆ Pb-Free, Halogen Free, RoHS/WEEE Compliant
- ◆ Nominal Dimensions: 0.6 x 0.3 x 0.25 mm
- ◆ Lead Finish: NiAu
- ◆ Marking: Marking Code
- ◆ Packaging: Tape and Reel

Applications

- ◆ USB 2.0 / USB 3.0
- ◆ MIPI / MDDI
- ◆ V-By-One
- ◆ eDP
- ◆ MHL
- ◆ LVDS

Nominal Dimensions

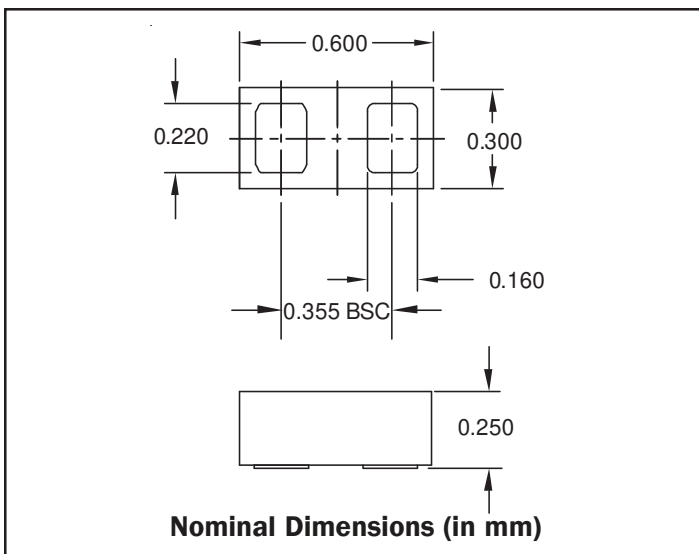

Schematic

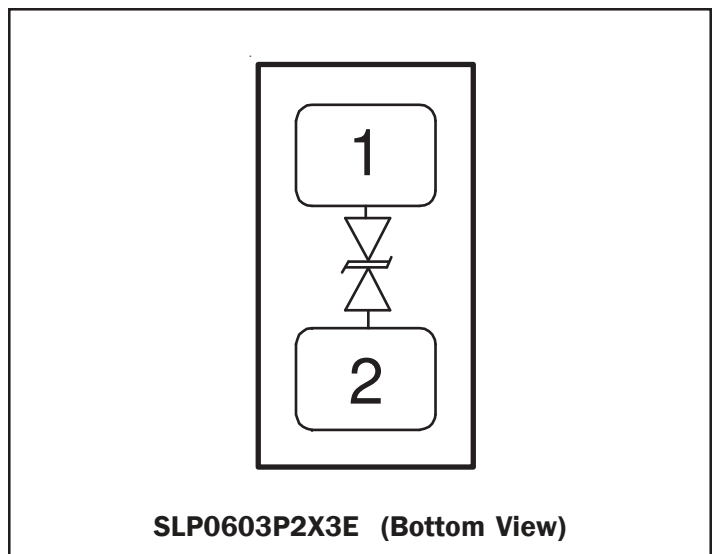

PROTECTION PRODUCTS
Absolute Maximum Rating

Rating	Symbol	Value	Units
Peak Pulse Power (tp = 8/20μs)	P_{pk}	30	Watts
Maximum Peak Pulse Current (tp = 8/20μs)	I_{pp}	4	Amps
ESD per IEC 61000-4-2 (Air) ¹ ESD per IEC 61000-4-2 (Contact) ¹	V_{ESD}	+/- 18 +/- 18	kV
Operating Temperature	T_J	-40 to +85	°C
Storage Temperature	T_{STG}	-55 to +150	°C

Electrical Characteristics (T=25°C)

Parameter	Symbol	Conditions	Minimum	Typical	Maximum	Units
Reverse Stand-Off Voltage	V_{RWM}	Pin 1 to 2 or 2 to 1			3.3	V
Holding Voltage	V_{HOLD}	$I_{HOLD} = 50mA$ Pin 1 to 2 or 2 to 1	1.2	2.8	4.4	V
Reverse Leakage Current	I_R	$V_{RWM} = 3.3V, T=25°C$ Pin 1 to 2 or 2 to 1		<1	50	nA
Clamping Voltage	V_C	$I_{pp} = 1A, tp = 8/20μs$ Pin 1 to 2 or 2 to 1		3.8	5.5	V
Clamping Voltage	V_C	$I_{pp} = 4A, tp = 8/20μs$ Pin 1 to 2 or 2 to 1		5.5	7.5	V
ESD Clamping Voltage ²	V_C	IPP = 4A, t _{lp} = 0.2/100ns		5		V
ESD Clamping Voltage ²	V_C	IPP = 16A, t _{lp} = 0.2/100ns		8.3		V
Trigger Voltage ²	V_{TRIG}	tp = 0.2/100ns		8.8		V
Dynamic Resistance ^{2, 3}	R_D	tp = 0.2/100ns		0.27		Ohms
Junction Capacitance	C_J	$V_R = 0V, f = 1MHz$		0.35	0.45	pF

Notes

- 1)ESD gun return path connected to ESD ground reference plane.
- 2)Transmission Line Pulse Test (TLP) Settings: $t_p = 100ns$, $t_r = 0.2ns$, I_{TLP} and V_{TLP} averaging window: $t_1 = 70ns$ to $t_2 = 90ns$.
- 3) Dynamic resistance calculated from $I_{TLP} = 4A$ to $I_{TLP} = 16A$

PROTECTION PRODUCTS

Typical Characteristics

Non-Repetitive Peak Pulse Power vs. Pulse Time

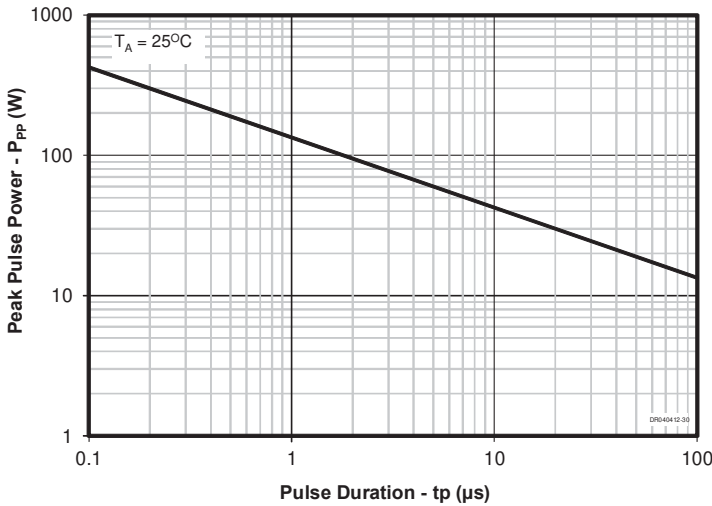

Clamping Voltage vs. Peak Pulse Current (t_p=8/20us)

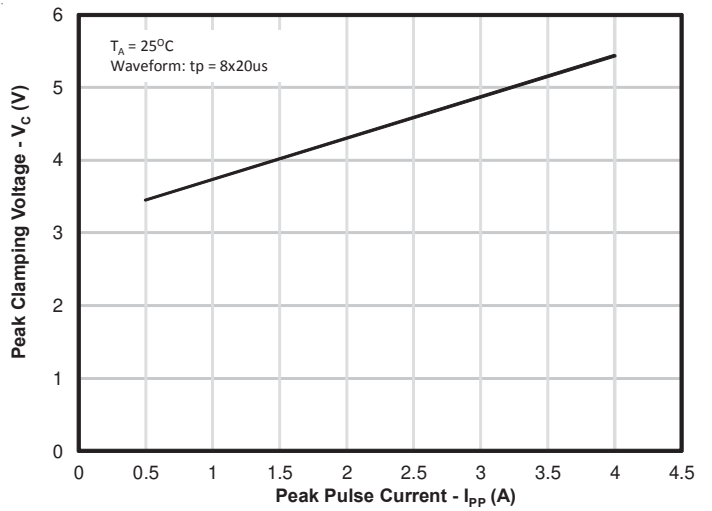

TLP Characteristic (Positive)

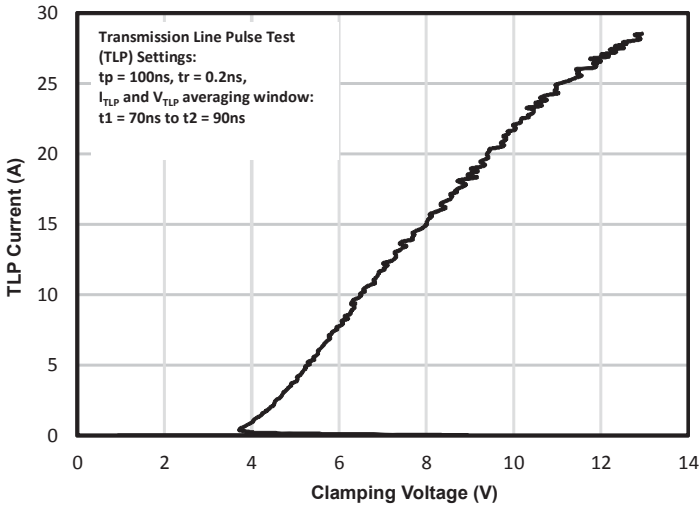

TLP Characteristic (Negative)

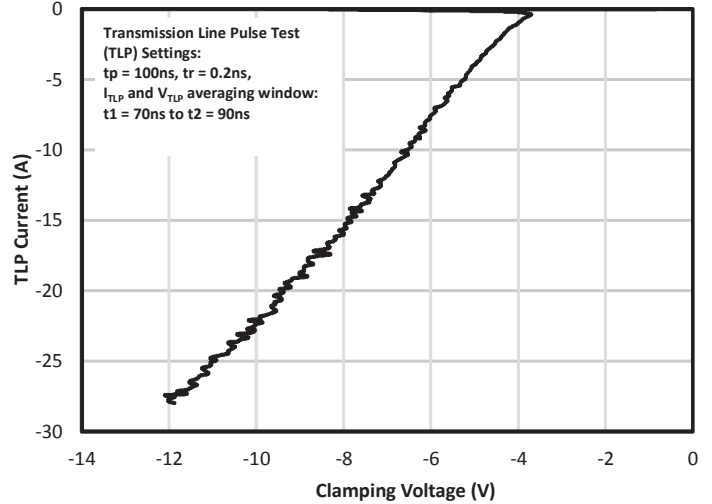

ESD Clamping (+8kV Contact per IEC 61000-4-2)

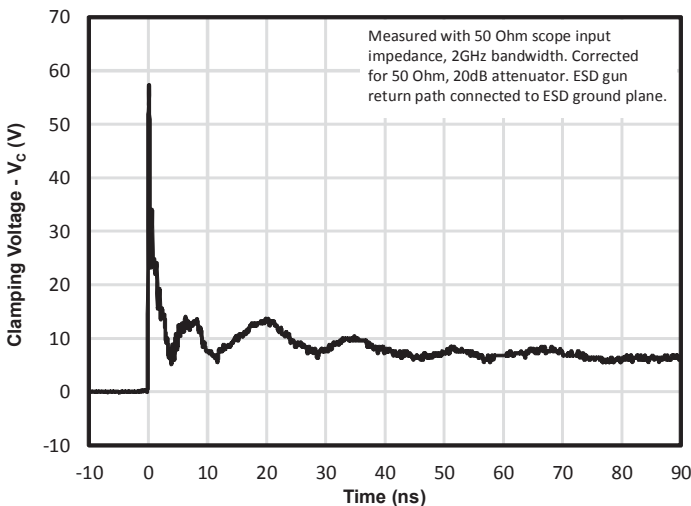

ESD Clamping (-8kV Contact per IEC 61000-4-2)

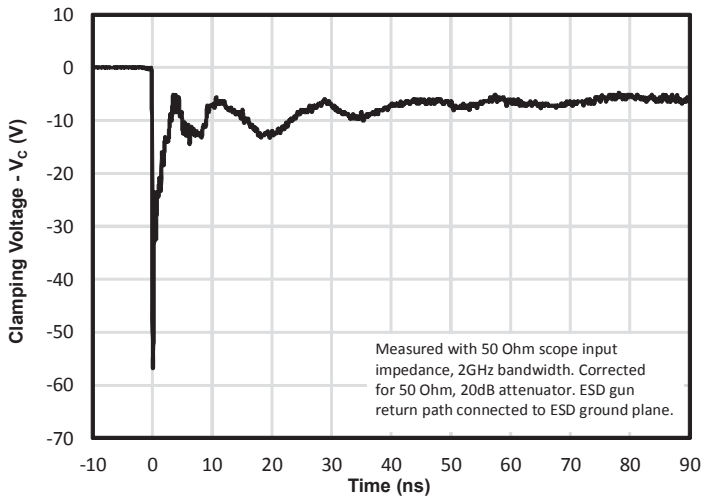

PROTECTION PRODUCTS

Typical Characteristics

Junction Capacitance vs. Reverse Voltage

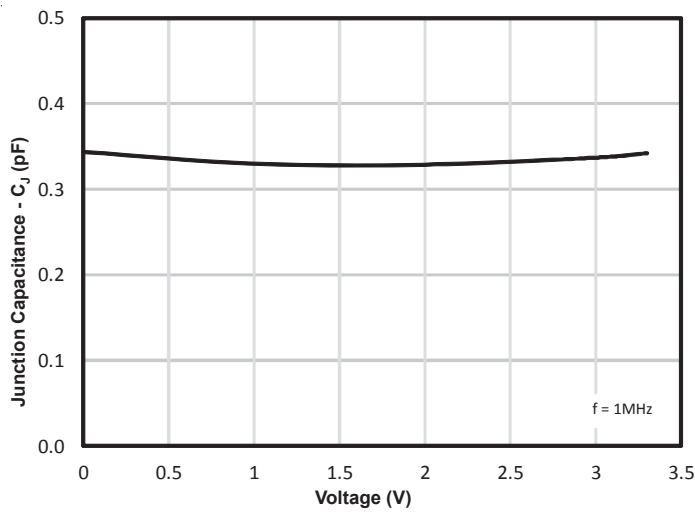

Junction Capacitance vs. Temperature

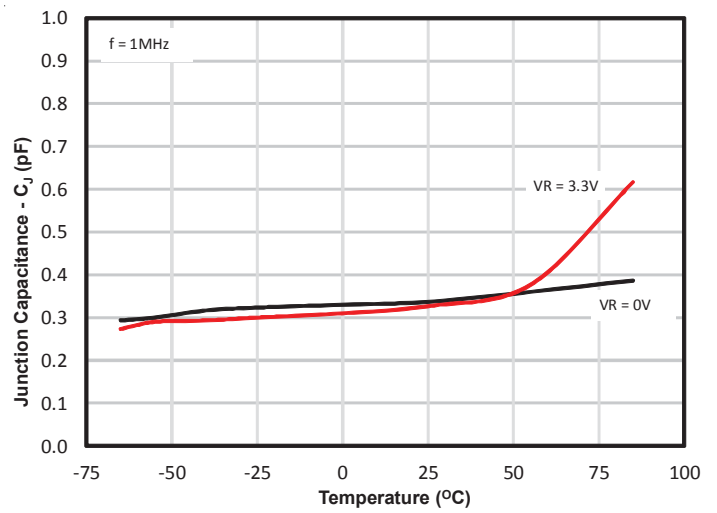

Typical Insertion Loss S21

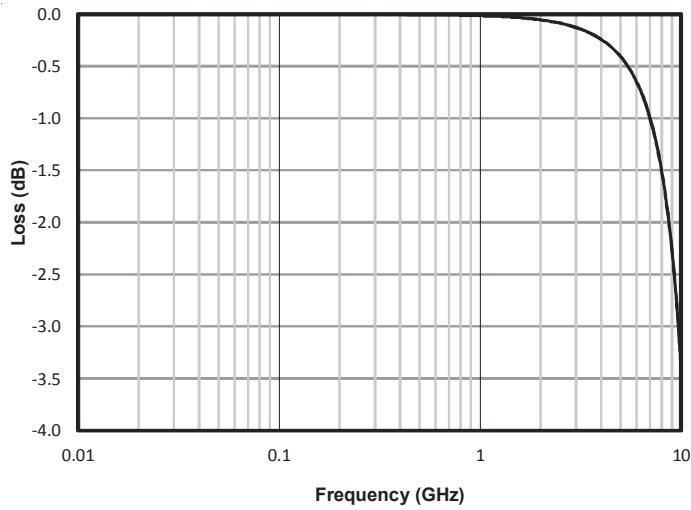

PROTECTION PRODUCTS
Applications Information
Assembly Guidelines

The small size of this device means that some care must be taken during the mounting process to insure reliable solder joints. The figure at the right details Semtech's recommended aperture based on the assembly guidelines detailed in the table below. Note that these are only recommendations and should serve only as a starting point for design since there are many factors that affect the assembly process. Exact manufacturing parameters will require some experimentation to get the desired solder application.

Assembly Parameter	Recommendation
Solder Stencil Design	Laser cut, Electro-polished
Aperture shape	Rectangular with rounded corners
Solder Stencil Thickness	0.100 mm (0.004")
Solder Paste Type	Type 4 size sphere or smaller
Solder Reflow Profile	Per JEDEC J-STD-020
PCB Solder Pad Design	Non-Solder mask defined
PCB Pad Finish	OSP OR NiAu

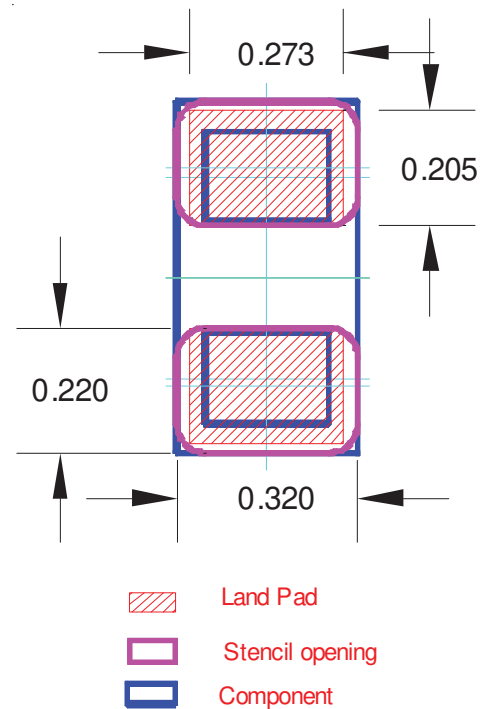
Recommended Mounting Pattern

PROTECTION PRODUCTS

Outline Drawing - SLP0603P2X3E

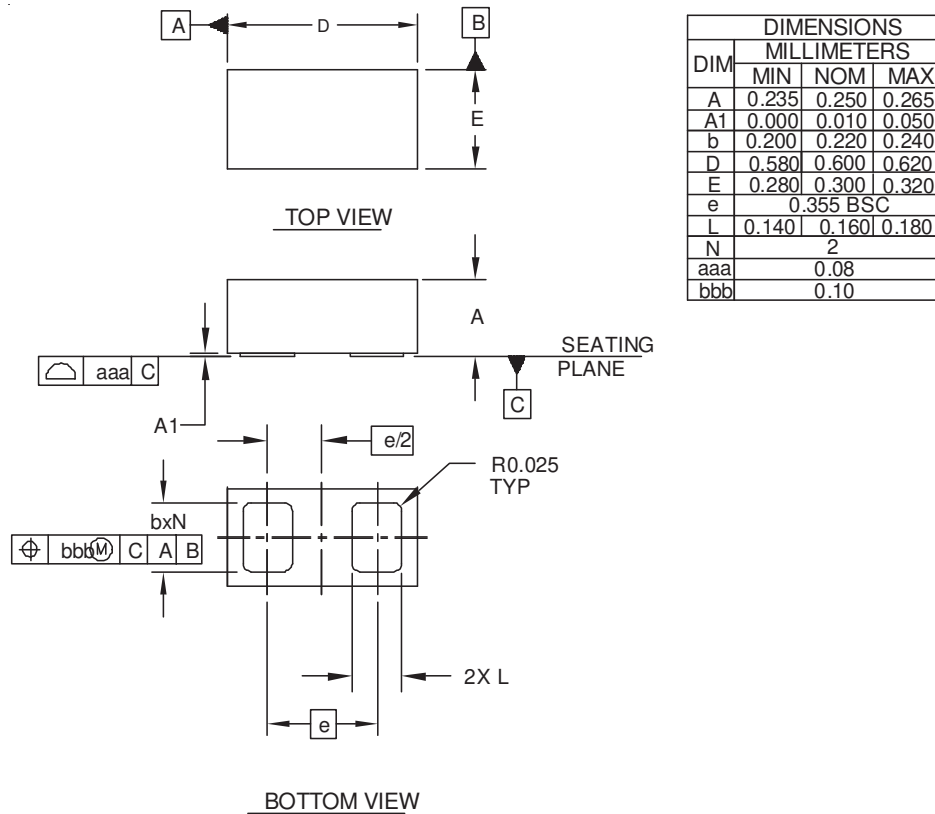

- NOTES:
1. CONTROLLING DIMENSIONS ARE IN MILLIMETERS(ANGLES IN DEGREES).

Land Pattern - SLP0603P2X3E

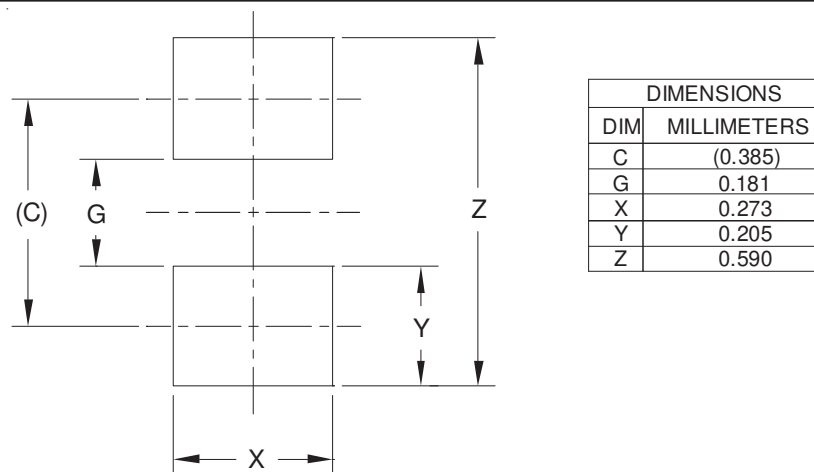

- NOTES:
1. CONTROLLING DIMENSIONS ARE IN MILLIMETERS (ANGLES IN DEGREES).
 2. THIS LAND PATTERN IS FOR REFERENCE PURPOSES ONLY .
CONSULT YOUR MANUFACTURING GROUP TO ENSURE YOUR
COMPANY'S MANUFACTURING GUIDELINES ARE MET .

PROTECTION PRODUCTS

Marking Code



Ordering Information

Part Number	Qty per Reel	Pocket Pitch	Reel Size
RClamp3331Y.TFT	15,000	2mm	7 Inch

Notes:

RailClamp and RClamp are trademarks of Semtech Corporation

Note:
Device is electrically symmetrical

Carrier Tape Specification

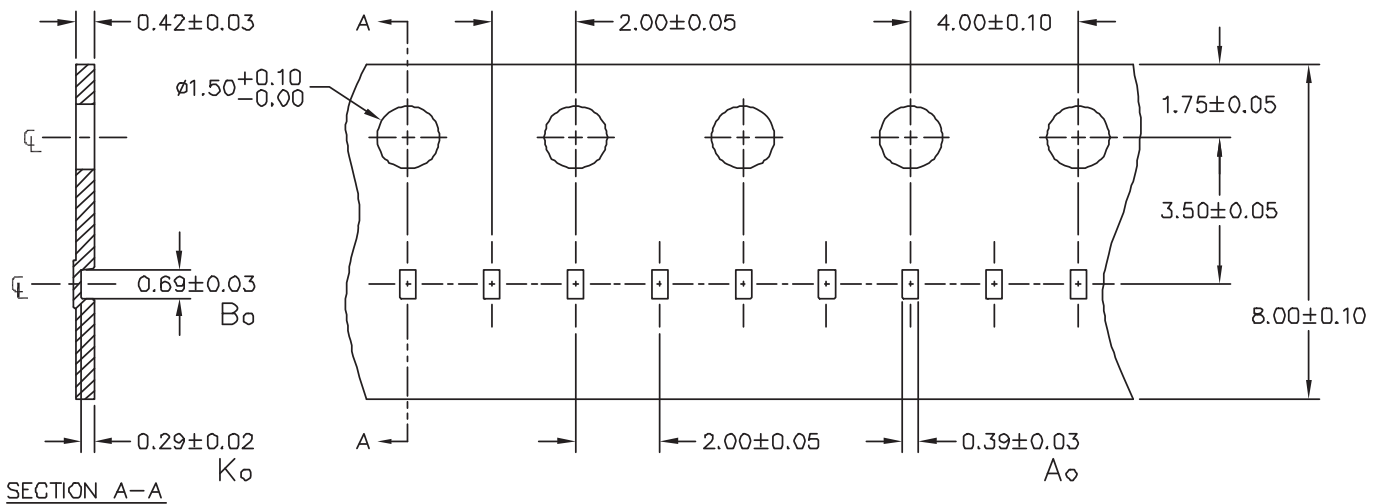

NOTES: ALL DIMENSIONS IN MILLIMETERS UNLESS OTHERWISE SPECIFIED.

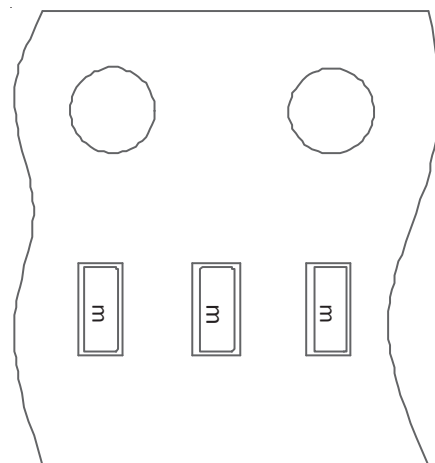

Device Orientation in Tape

Contact Information

Semtech Corporation
Protection Products Division
200 Flynn Rd., Camarillo, CA 93012
Phone: (805)498-2111 FAX (805)498-3804