



Chipsmall Limited consists of a professional team with an average of over 10 year of expertise in the distribution of electronic components. Based in Hongkong, we have already established firm and mutual-benefit business relationships with customers from,Europe,America and south Asia,supplying obsolete and hard-to-find components to meet their specific needs.

With the principle of “Quality Parts,Customers Priority,Honest Operation,and Considerate Service”,our business mainly focus on the distribution of electronic components. Line cards we deal with include Microchip,ALPS,ROHM,Xilinx,Pulse,ON,Everlight and Freescale. Main products comprise IC,Modules,Potentiometer,IC Socket,Relay,Connector.Our parts cover such applications as commercial,industrial, and automotives areas.

We are looking forward to setting up business relationship with you and hope to provide you with the best service and solution. Let us make a better world for our industry!



## Contact us

Tel: +86-755-8981 8866 Fax: +86-755-8427 6832

Email & Skype: info@chipsmall.com Web: www.chipsmall.com

Address: A1208, Overseas Decoration Building, #122 Zhenhua RD., Futian, Shenzhen, China



### PROTECTION PRODUCTS - RailClamp®

#### Description

RailClamp® TVS diodes are specifically designed to protect sensitive components which are connected to high-speed data and transmission lines from overvoltage caused by ESD (electrostatic discharge), CDE (cable discharge events), and EFT (electrical fast transients).

The unique design incorporates surge rated, low capacitance steering diodes and a TVS diode in a single package. The RClamp®3374N is designed to replace up to two components for board level GbE protection. Each device is designed to protect two line pairs. This is accomplished by routing traces through the device. When connected in this fashion, the device can withstand a high level of surge current (40A, 8/20us) while maintaining a low loading capacitance of less than 5pF. The high surge capability means it can be used in high threat environments in applications such as Gigabit Ethernet, telecommunication lines, and LVDS interfaces.

The RClamp3374N is constructed using Semtech's proprietary EPD process technology. The EPD process provides low stand-off voltages with significant reductions in leakage current and capacitance over silicon-avalanche diode processes. It features a true operating voltage of 3.3 volts for superior protection.

The RClamp3374N is in a 10-pin SLP3020N10 package. It measures 3.0 x 2.0 x 0.60mm. The leads are finished with lead-free NiPdAu.

#### Features

- ◆ Transient protection for high-speed data lines to **IEC 61000-4-2 (ESD) ±30kV (air), ±30kV (contact)**  
**IEC 61000-4-4 (EFT) 40A (5/50ns)**  
**IEC 61000-4-5 (Lightning) 40A (8/20µs)**
- ◆ Array of surge rated diodes with internal TVS Diode
- ◆ Qualified to **AEC-Q100 Grade 1** (-45 to +125°C)
- ◆ Protects up to eight lines
- ◆ Low capacitance for high-speed interfaces
- ◆ Low variation in capacitance vs. bias voltage
- ◆ Low clamping voltage
- ◆ Low operating voltage: 3.3V
- ◆ Solid-state silicon-avalanche technology

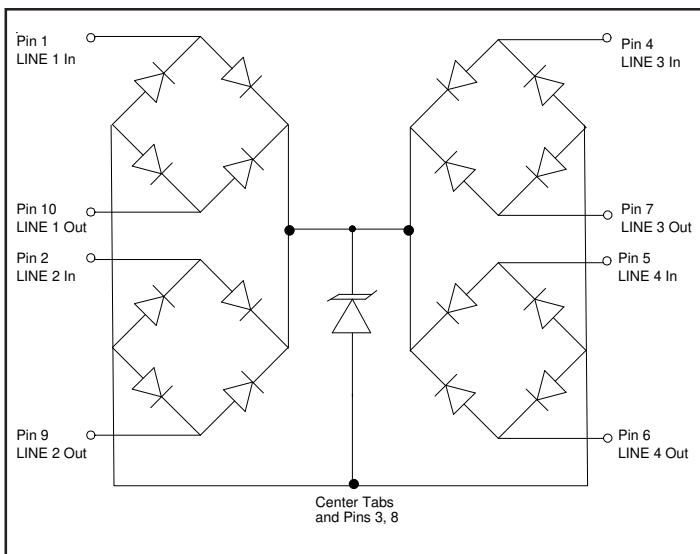
#### Mechanical Characteristics

- ◆ SLP3020N10 10L package
- ◆ Pb-Free, Halogen Free, RoHS/WEEE Compliant
- ◆ Nominal Dimensions: 3.0 x 2.0 x 0.60 mm
- ◆ Lead Finish: NiPdAu
- ◆ Molding compound flammability rating: UL 94V-0
- ◆ Marking : Marking code + Date code
- ◆ Packaging : Tape and Reel

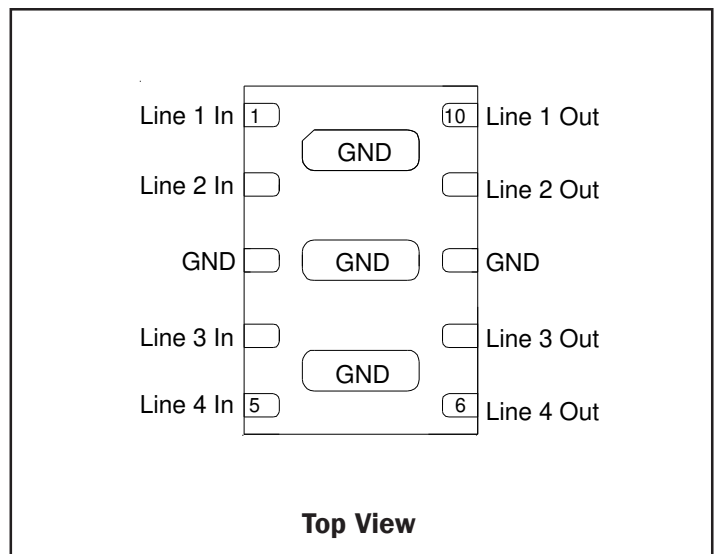
#### Applications

- ◆ 10/100/1000 Ethernet
- ◆ Automotive
- ◆ Central Office Equipment
- ◆ LVDS Interfaces
- ◆ MagJacks / Integrated Magnetics
- ◆ Notebooks / Desktops / Servers

#### Circuit Diagram



#### Pin Configuration



**PROTECTION PRODUCTS**
**Absolute Maximum Rating**

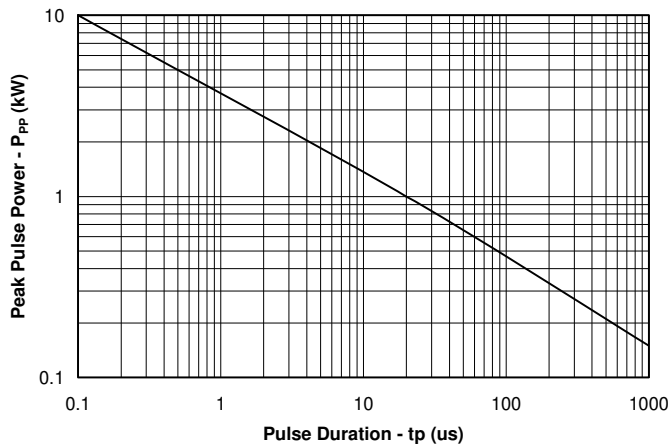
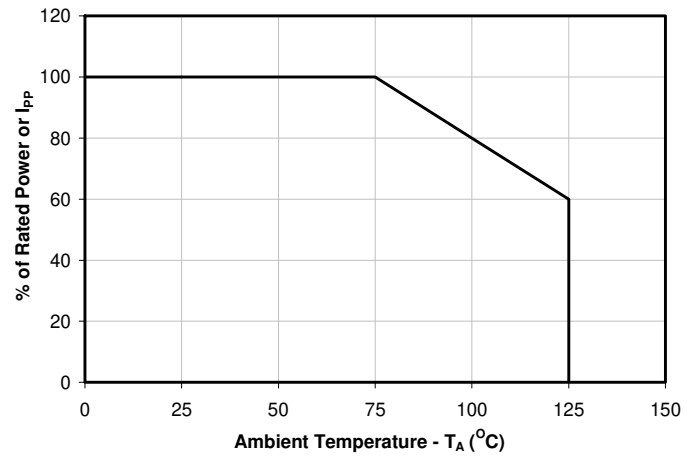
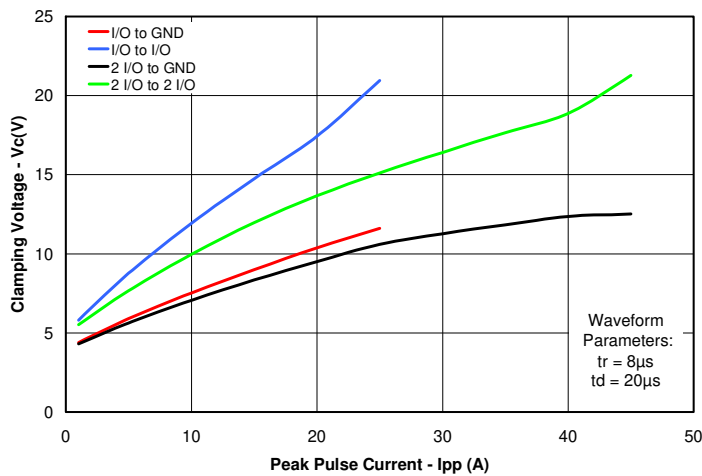
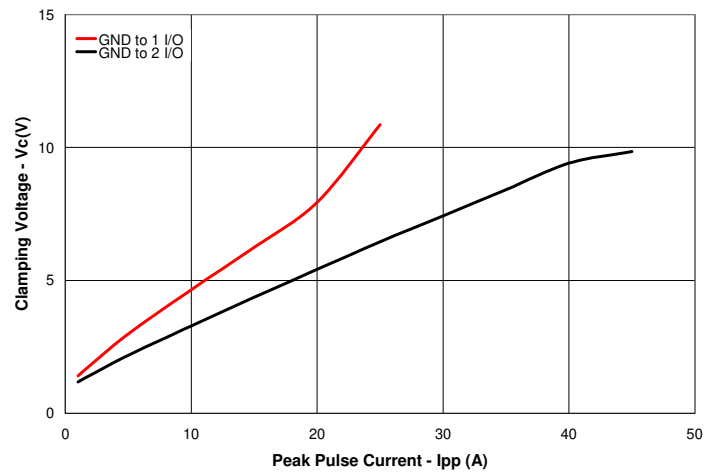
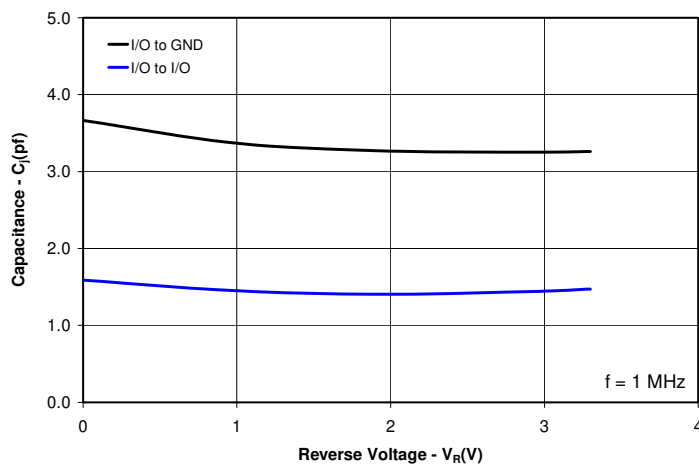
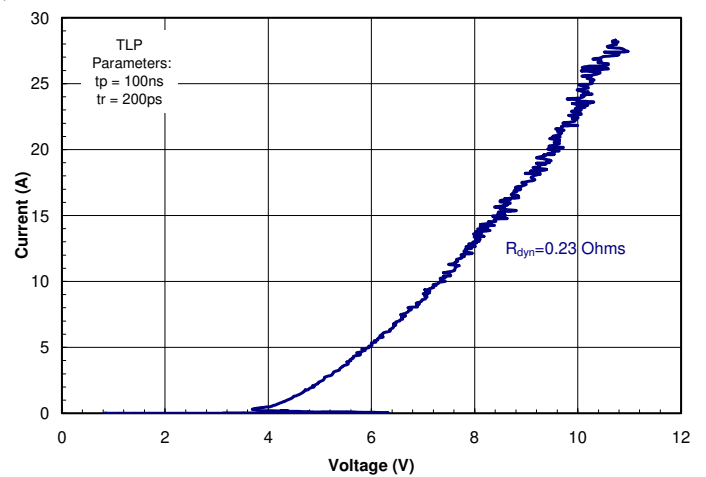
Rating	Symbol	Value	Units
Peak Pulse Power ( $t_p = 8/20\mu s$ ) <sup>1</sup>	$P_{pk}$	1000	Watts
Peak Pulse Current ( $t_p = 8/20\mu s$ ) <sup>1</sup>	$I_{pp}$	40	A
ESD per IEC 61000-4-2 (Air) ESD per IEC 61000-4-2 (Contact)	$V_{ESD}$	+/-30 +/-30	kV
Operating Temperature	$T_j$	-40 to +125	°C
Storage Temperature	$T_{STG}$	-55 to +150	°C

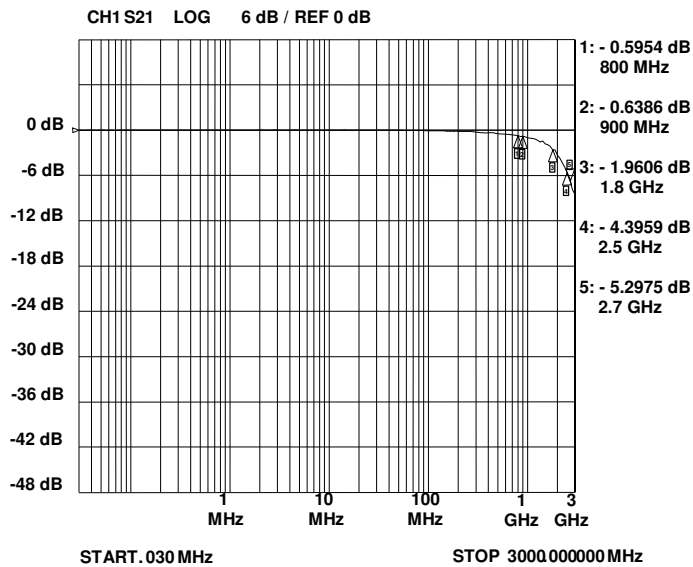
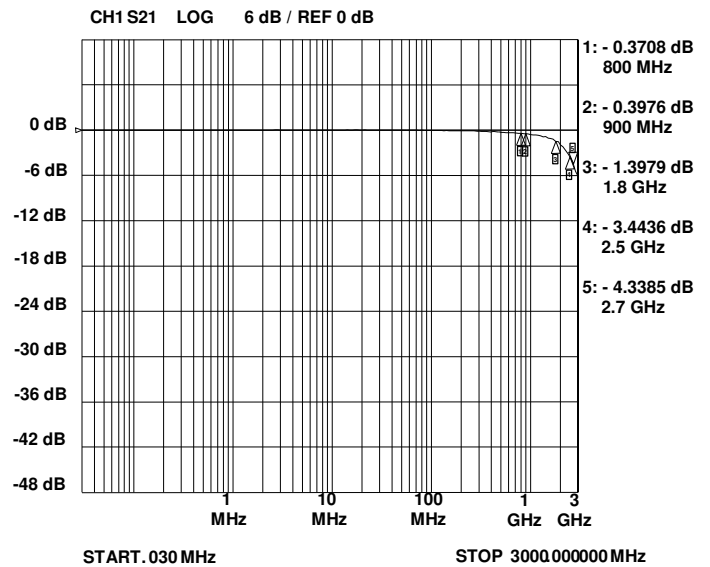
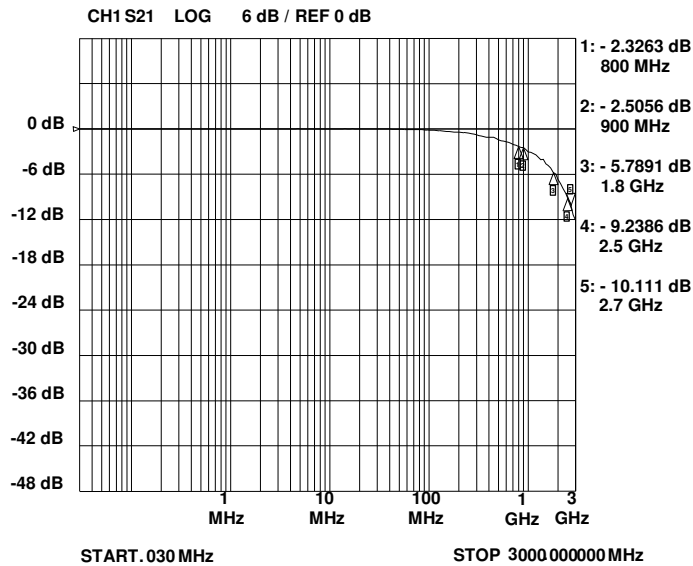
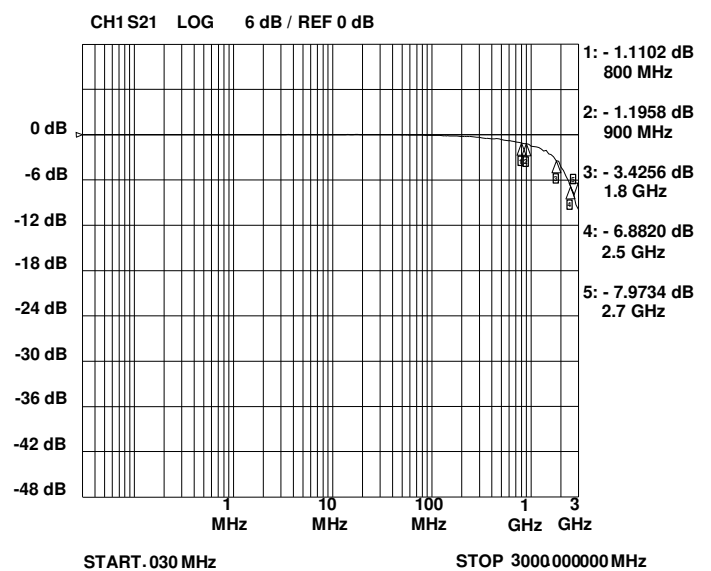
**Electrical Characteristics (T=25°C unless otherwise specified)**

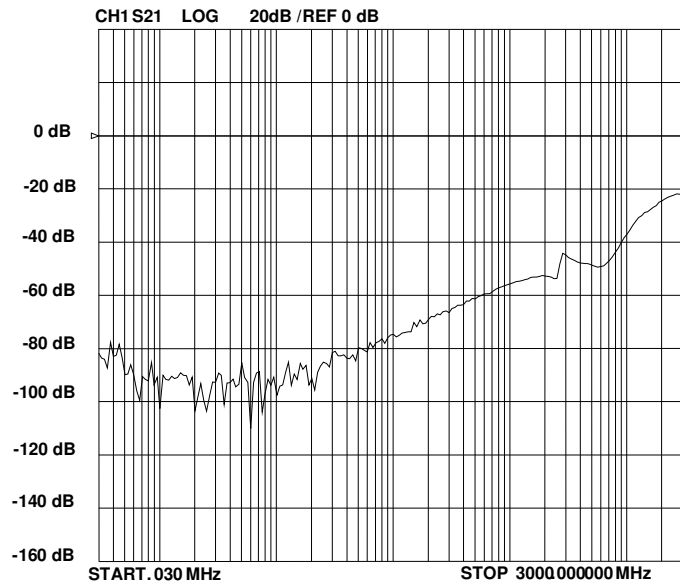
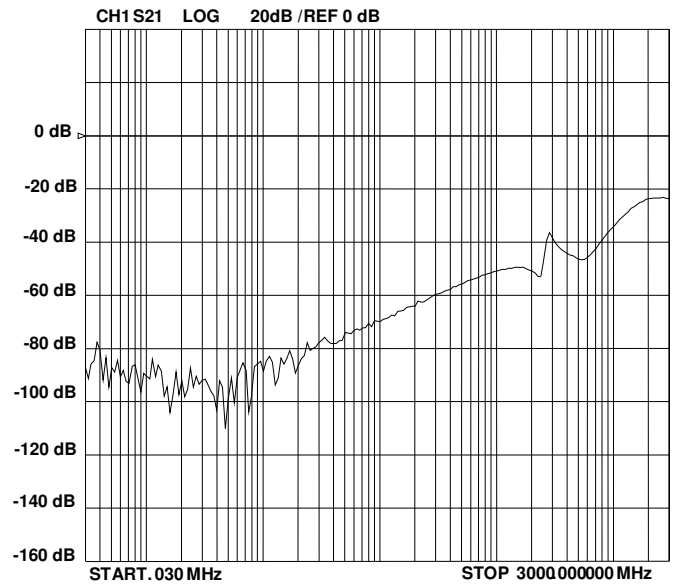
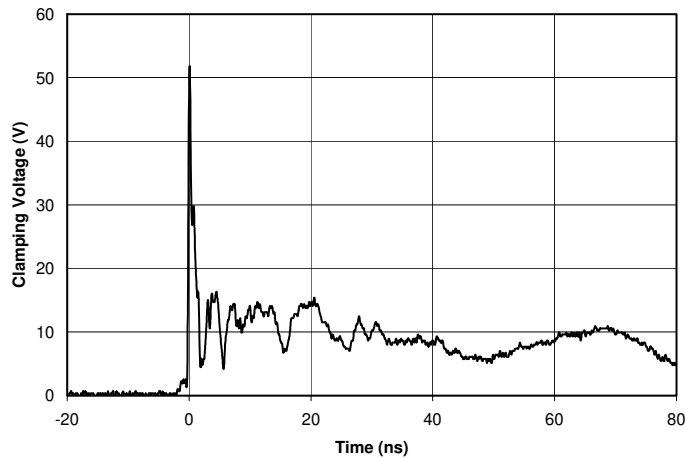
Parameter	Symbol	Conditions	Minimum	Typical	Maximum	Units
Reverse Stand-Off Voltage	$V_{RWM}$				3.3	V
Punch-Through Voltage	$V_{PT}$	$I_{PT} = 2\mu A$	3.5			V
Snap-Back Voltage	$V_{SB}$	$I_{SB} = 50mA$	2.8			V
Reverse Leakage Current	$I_R$	$V_{RWM} = 3.3V, T=25^\circ C$			0.5	$\mu A$
Reverse Leakage Current	$I_R$	$V_{RWM} = 3.3V, T=125^\circ C$			1	$\mu A$
Clamping Voltage <sup>2</sup>	$V_C$	$I_{pp} = 1A, t_p = 8/20\mu s$ Any I/O to Ground			5.5	V
Clamping Voltage <sup>2</sup>	$V_C$	$I_{pp} = 10A, t_p = 8/20\mu s$ Any 1 I/O to Ground			10.5	V
Clamping Voltage <sup>2</sup>	$V_C$	$I_{pp} = 25A, t_p = 8/20\mu s$ Any I/O to Ground			18	V
Clamping Voltage <sup>1,2</sup>	$V_C$	$I_{pp} = 40A, t_p = 8/20\mu s$ Line-to-Line, two I/O pins connected together on each line (Note 1)			25	V
Junction Capacitance <sup>2</sup>	$C_j$	$V_R = 0V, f = 1MHz$ Any I/O to Ground		3.6	5	pF
		$V_R = 0V, f = 1MHz$ Between I/O pins		1.7		pF

**Notes:**

- 1) Ratings with 2 pins connected together per the recommended configuration (ie pin 1 connected to pin 10, pin 2 connected to pin 9, pin 4 connected to pin 7, and pin 5 connected to pin 6).
- 2) Guaranteed by design (not production tested)

**PROTECTION PRODUCTS**
**Typical Characteristics**
**Non-Repetitive Peak Pulse Power vs. Pulse Time**

**Power Derating Curve**

**Clamping Voltage vs. Peak Pulse Current**

**Forward Clamping Voltage vs. Peak Pulse Current**

**Capacitance vs. Reverse Voltage**

**Typical TLP Characteristic**


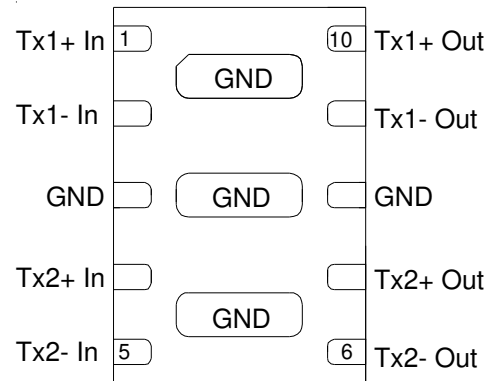
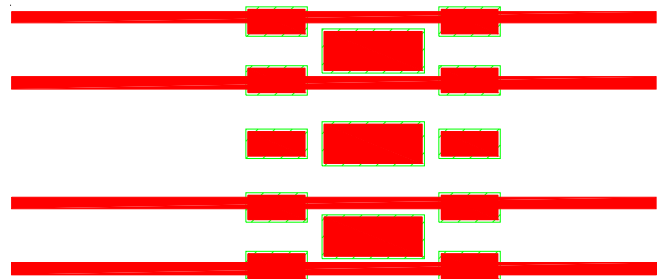
**PROTECTION PRODUCTS**
**Typical Characteristics (Con't)**
**Insertion Loss S21 (I/O to Gnd)**

**Insertion Loss S21 (I/O to I/O)**

**Insertion Loss S21 (2 I/O to Gnd)**

**Insertion Loss S21 (2 I/O to 2 I/O)**


**PROTECTION PRODUCTS**
**Typical Characteristics (Con't)**
**Analog Crosstalk (I/O to GND)**

**Analog Crosstalk (I/O to I/O)**

**ESD Clamping - I/O to Gnd  
(8kV Contact per IEC 61000-4-2)**


**Device Connection Options for Protection of Four High-Speed Data Lines**

This device is designed to protect four high-speed data lines (two line pairs). It has been optimized for use on Ethernet interfaces where large magnitude lightning and ESD surges are expected. The RClamp3374N is constructed using Semtech's proprietary EPD process technology. The EPD process provides low stand-off (turn-on) voltages with significant reductions while maintaining good clamping characteristics and high surge capability. They feature a true operating voltage of 3.3 volts. Each I/O pin pair features a low capacitance steering diode bridge that is designed to route harmful surge current into the internal low voltage TVS diode. Each data pair is rated to withstand 1000 Watts of surge power (8/20us impulse waveform). When placed on the PHY side of the magnetics, it can be used to meet the requirements of Telcordia GR-1089, K.20, K.21, and other high energy surge standards.

The RClamp3374N is designed with a flow through pin configuration for easy layout. In a GbE application, TX+ and TX- lines would enter at pins 1, 2, 4, and 5 and exit at pins 10, 9, 7, and 6 respectively. The traces should be unbroken and run under the device as shown. Pins 3 and 8 are electrically connected to the three center ground tabs. In a typical Ethernet application, these pins as well as the tabs should be left floating (i.e. not connected to ground).

**Pin Configuration**

**Layout Example**


**PROTECTION PRODUCTS**
**Applications Information**
**Gigabit Ethernet Protection Solutions**

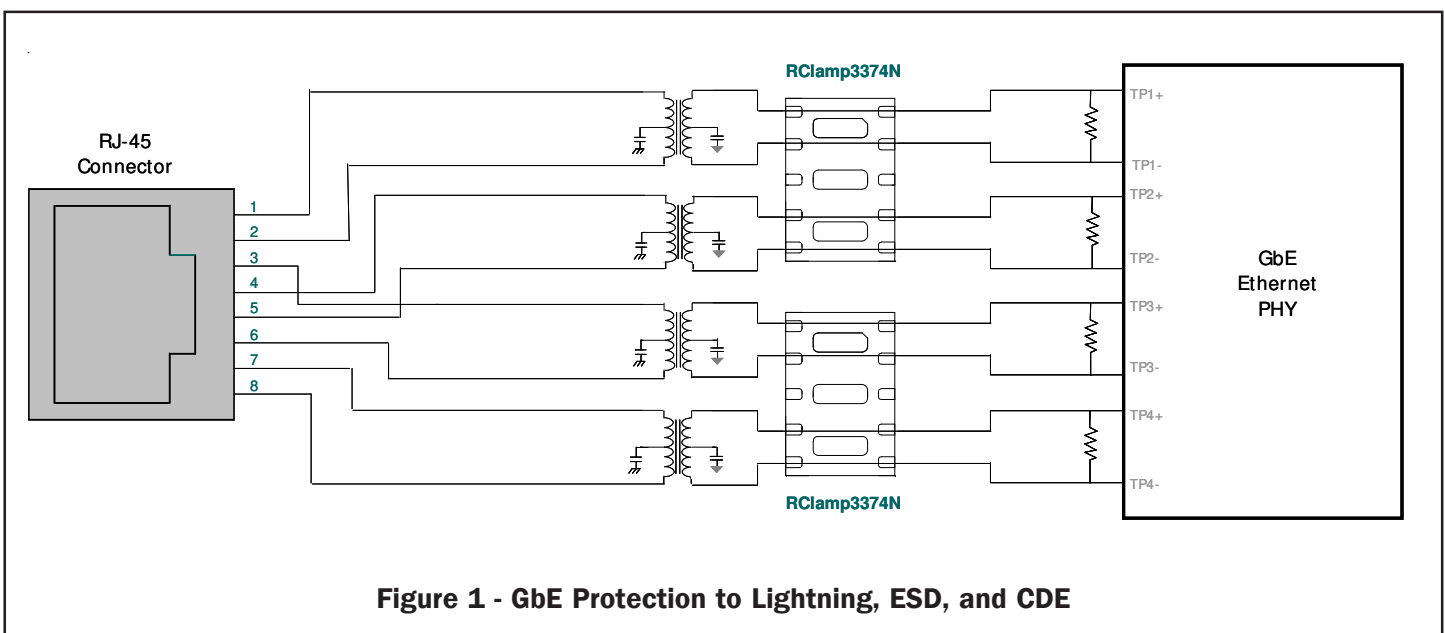
Ethernet systems with connections external to the building are subject to high-level transient threats. This type of equipment may even be required to meet the surge immunity requirements of Telcordia GR-1089. Reliable protection of the Ethernet transceiver requires a device that can absorb the expected transient energy, clamp the incoming surge to a safe level, and yet remain transparent to the system under normal operation. The RClamp3374N has been designed to meet these demanding requirements.

**Transient Protection**

When designing Ethernet protection, the entire system must be considered. An Ethernet port includes interface magnetics in the form of transformers and common mode chokes. Transformers and chokes can be discrete components, but integrated solutions that include the RJ-45 connector, resistors, capacitors, and protection are also available. In either case, the transformer will provide a high level of common mode isolation to external voltages, but no protection for metallic (line-to-line) surges. During a metallic transient event, current will flow into one line, through the transformer and back to the source. As the current flows, it charges the windings of the transformer on the line side. Once the surge is removed, the windings on the line side will stop charging and will transfer its stored energy to the IC side where the PHY IC is located. The magnitude and

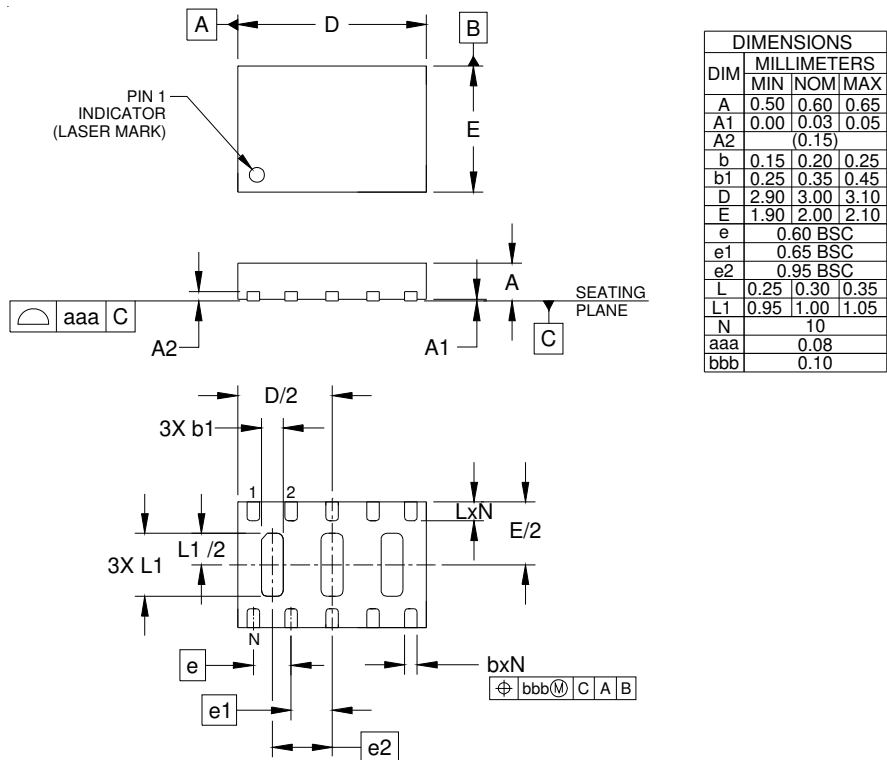
duration of the surge is attenuated by the inductance of the magnetics. The amount of attenuation will vary by vendor and configuration of the magnetics. It is this transferred energy that must be clamped by the protection circuitry.

A typical protection scheme which utilizes the RClamp3374N is shown in Figure 1. One device is placed across two line pairs and is located on the PHY side of the transformer as close to the magnetics as possible. This is done to minimize parasitic inductance and improve clamping performance. In this design, the isolation voltage of the transformer is relied upon to suppress common mode lightning surges. High voltage capacitors and resistors are commonly utilized from the center tap to ground to aid in transient protection. Metallic surges will be transferred in some form to the PHY side and clamped by the RClamp3374N. The RClamp3374N will turn on when the voltage across it exceeds the punch-through voltage of the device. Low voltage turn on is important since many PHY chips have integrated ESD protection structures. These structures are for protection of the device during manufacture and are not designed to handle large amounts of energy. Should they turn on before the external protection, they can be damaged resulting in failure of the PHY chip.

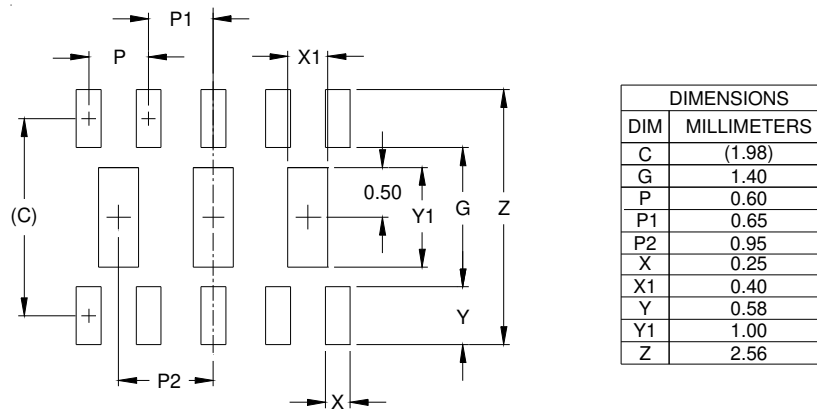


**Figure 1 - GbE Protection to Lightning, ESD, and CDE**



**PROTECTION PRODUCTS**
**Outline Drawing - SLP3020N10**


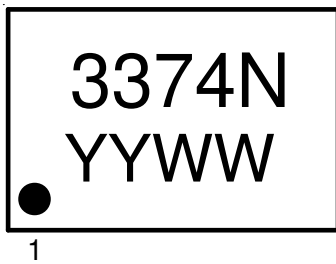
NOTES:  
 1. CONTROLLING DIMENSIONS ARE IN MILLIMETERS (ANGLES IN DEGREES).

**Land Pattern - SLP3020N10**


NOTES:  
 1. CONTROLLING DIMENSIONS ARE IN MILLIMETERS (ANGLES IN DEGREES).  
 2. THIS LAND PATTERN IS FOR REFERENCE PURPOSES ONLY.  
 CONSULT YOUR MANUFACTURING GROUP TO ENSURE YOUR COMPANY'S MANUFACTURING GUIDELINES ARE MET.

## PROTECTION PRODUCTS

### Marking Codes



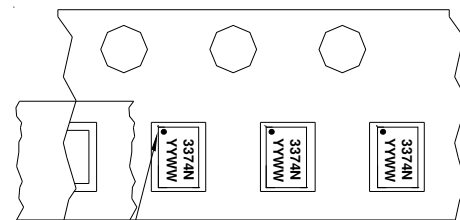
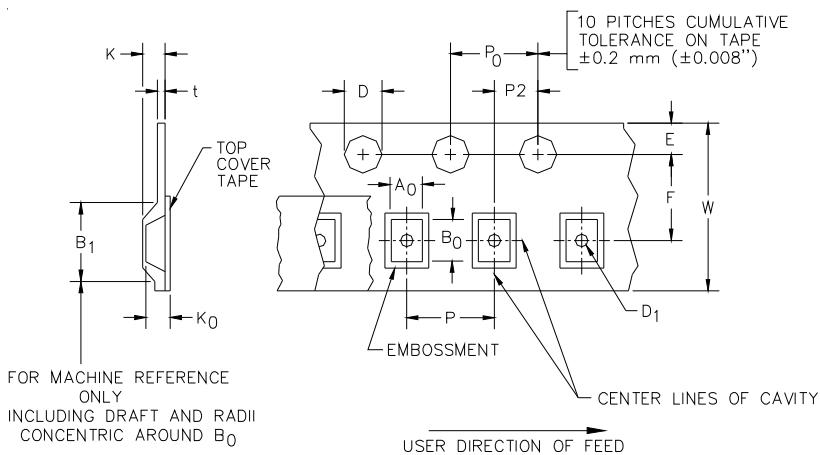
### Ordering Information

Part Number	Working Voltage	Qty per Reel	Reel Size
RClamp3374N.TCT	3.3 Volts	3,000	7 Inch

RailClamp and RClamp are trademarks of Semtech Corporation

YYWW = Date Code

### Carrier Tape Specification



Pin 1 Location (Towards Sprocket Holes)

→ User Direction of feed

### Device Orientation in Tape

A0	B0	K0
2.24 +/-0.05 mm	3.23 +/-0.05 mm	0.93 +/-0.05 mm

Tape Width	B, (Max)	D	D1	E	F	K (MAX)	P	P0	P2	T(MAX)	W
8 mm	4.2 mm	1.5 + 0.1 mm - 0.0 mm )	0.5 mm ±0.05	1.750±.10 mm	3.5±0.05 mm	2.4 mm	4.0±0.1 mm	4.0±0.1 mm	2.0±0.05 mm	0.4 mm	8.0 mm + 0.3 mm - 0.1 mm

### Contact Information

Semtech Corporation  
 Protection Products Division  
 200 Flynn Road, Camarillo, CA 93012  
 Phone: (805)498-2111 FAX (805)498-3804