



Chipsmall Limited consists of a professional team with an average of over 10 year of expertise in the distribution of electronic components. Based in Hongkong, we have already established firm and mutual-benefit business relationships with customers from,Europe,America and south Asia,supplying obsolete and hard-to-find components to meet their specific needs.

With the principle of "Quality Parts,Customers Priority,Honest Operation,and Considerate Service",our business mainly focus on the distribution of electronic components. Line cards we deal with include Microchip,ALPS,ROHM,Xilinx,Pulse,ON,Everlight and Freescale. Main products comprise IC,Modules,Potentiometer,IC Socket,Relay,Connector.Our parts cover such applications as commercial,industrial, and automotives areas.

We are looking forward to setting up business relationship with you and hope to provide you with the best service and solution. Let us make a better world for our industry!



## Contact us

Tel: +86-755-8981 8866 Fax: +86-755-8427 6832

Email & Skype: info@chipsmall.com Web: www.chipsmall.com

Address: A1208, Overseas Decoration Building, #122 Zhenhua RD., Futian, Shenzhen, China



RD1-4020

DisplayPort to DVI output

User Guide

Rev. B

**MegaChips**

**MegaChips' Proprietary and Confidential**

This information shall not be shared or distributed outside the company and will be exchanged based on the signed proprietary information exchange agreement. MegaChips reserves the right to make any change herein at any time without prior notice. MegaChips does not assume any responsibility or liability arising out of application or use of any product or service described herein except as explicitly agreed upon.

## Contents

1. Purpose and scope .....	4
2. Description.....	4
3. Set up instructions.....	4
3.1. I2C host port.....	5
3.2. In-System Programming (ISP).....	5
4. Diagnosis.....	6
4.1. Board description .....	7
4.2. Principal components and functions .....	9
4.3. Connector descriptions .....	10
4.4. Switches.....	14
4.5. Stuffing options .....	14
4.5.1. Single/dual TTL.....	14
4.5.2. IROM/SPI-Flash.....	14
5. Revision history .....	15

## List of tables

Table 1.	Principal components and functions.....	9
Table 2.	Document revision history .....	15

## List of figures

Figure 1.	Connection set up.....	5
Figure 2.	Block diagram .....	<b>Error! Bookmark not defined.</b>
Figure 3.	Board picture.....	<b>Error! Bookmark not defined.</b>

## 1. Purpose and scope

This document provides description and setup instructions for the DisplayPort® Receiver STDP4020 reference design board [RD1-4020\_400-530] targeted for DP to DVI conversion applications.

## 2. Description

The STDP4020 is an integrated circuit featuring a four lane DisplayPort receiver, quad LVDS & LVTTTL transmitter with I2S and SPDIF audio outputs for digital audio-video conversion application. This device also includes SPI interface, I2C Slave (Host Interface), I2C Master Interface, UART (GProbe) interface, and general-purpose IO pins. The RD1-4020 is a low cost compact four layer board that includes necessary interfaces and features to fully demonstrate the STDP4020 receiver functionalities. The RD1-4020 board includes discrete TMDS transmitter chips, converting LVTTTL output from STDP4020 into DVI. This board is capable of handling both single link and dual link DVI output supporting video resolution from 640 x 480 up to 2560 x 1600. The RD1-4020 also features digital audio outputs SPDIF and I2S up to 8 Ch.

This reference design meets the following objectives:

1. Stand-alone operation: Includes the necessary firmware (either IROM or external SPI) to work independently; this means the intended functionalities are performed without depending on external (Host) controllers.
2. Slave configuration: Provision to configure the device by an external Host controller through the Host Interface to I2C (most likely when no SPI Flash is used).

## 3. Set up instructions

The picture below [Figure 1] is a connection diagram showing the RD1-4020 board used for transferring a PC DisplayPort signal into a dual link DVI output. Software utility: GProbe tool (ver 5.7.X.X), WinI2C tool



Figure 1. Connection diagram: PC DP signal to dual link DVI output

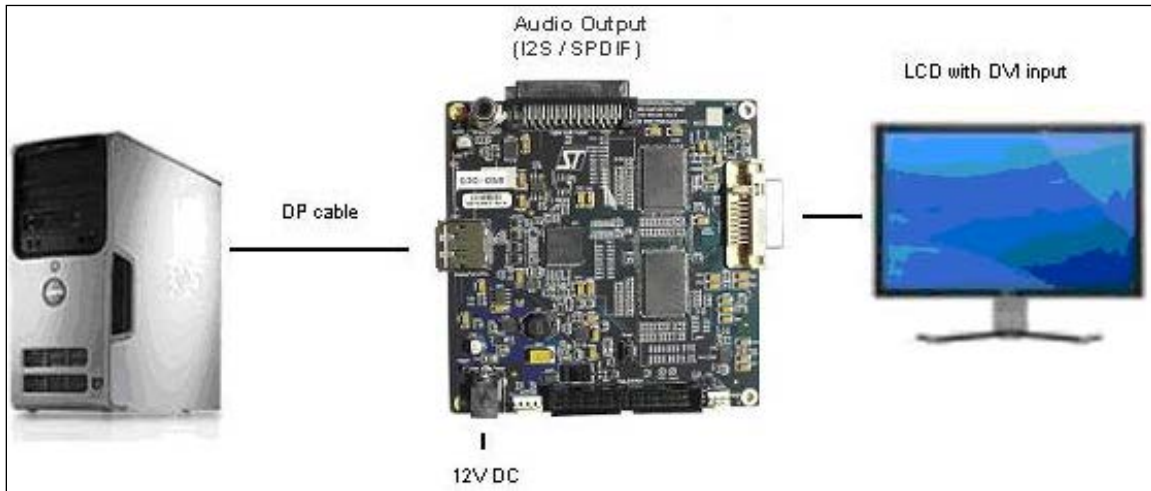

This board uses the standard DisplayPort connector recommended in the DP specification to connect the DisplayPort output from the PC to the input of the RD1-4020 board, and a dual link DVI connector to interface with a commercial DVI monitor.

1. Connect the DisplayPort output from a PC source to the RD1-4020 reference board using a DP cable.
2. Connect the output to a DVI monitor using a DVI cable. Connect the 12 V (4A) DC power brick supplied for powering the board. A DisplayPort source that supports DP-Audio transmission is recommended for testing digital audio output of the RD1-4020 board.
3. Once the connection is established, power ON the PC, DVI display, and the RD1-4020 (DP receiver) board. An image should pop up on the screen within 5-6 seconds.

### 3.1. I2C host port

Host connector (CN401) allows configuration of the STDP4020 IC from an external host (microcontroller) through conventional I2C interface. User can plug two wires into pin 5 and pin 6 of this connector to access the I2C port of the chip. STDP4020 default device ID is 0xE6/0xE7, but can be changed through bootstrap settings. Refer to the STDP4020 datasheet for further details.

### 3.2. In-System Programming (ISP)

RD1-4020 uses SPI Flash to store the firmware. In case of a new firmware upgrade, one of the following methods can be used.

1. ISP through DisplayPort connector: Allows programming the SPI Flash through DisplayPort input connector. Requires DP ISP board and GProbe software tool (contact MegaChips).
2. ISP through UART connector: Allows programming the SPI Flash through UART (RS232) connector. Requires GProbe board (RS232 converter circuit) and GProbe software tool (contact MegaChips).

## 4. Diagnosis

If the image does not come up, follow the steps below for diagnosis.

*Note: The diagnosis requires the MegaChips GProbe software and hardware tool. Contact MegaChips for the GProbe software and board.*

1. Install the GProbe diagnostic tool on a computer and set the baud rate to 115,200.
2. Connect MegaChips GProbe board (not supplied) to the serial port (or USB port if using USB version) of the computer.
3. Connect the other end of the GProbe board to connector (CN403) on the RD1-4020 board using 4-wire cable (part of the GProbe board).

*Note: CHECK POLARITY while connecting the cable; Pin 1 is marked on the board. The 4-wire cable connection from CN403 to GProbe board is 1 to 1.*

4. Hit the Reset button on the board (RESET SW402). You will see the firmware version and date of firmware in the GProbe window. This indicates the DP receiver IC is functional. If the message does not appear, reprogram the Flash using the ISP method described in the GProbe user guide.
5. Using an oscilloscope, check the video input and output from the STDP4020.

*Note: Refer to the STDP4020 datasheet for pin out descriptions.*

4.1. Board description

Figure 2. Block diagram

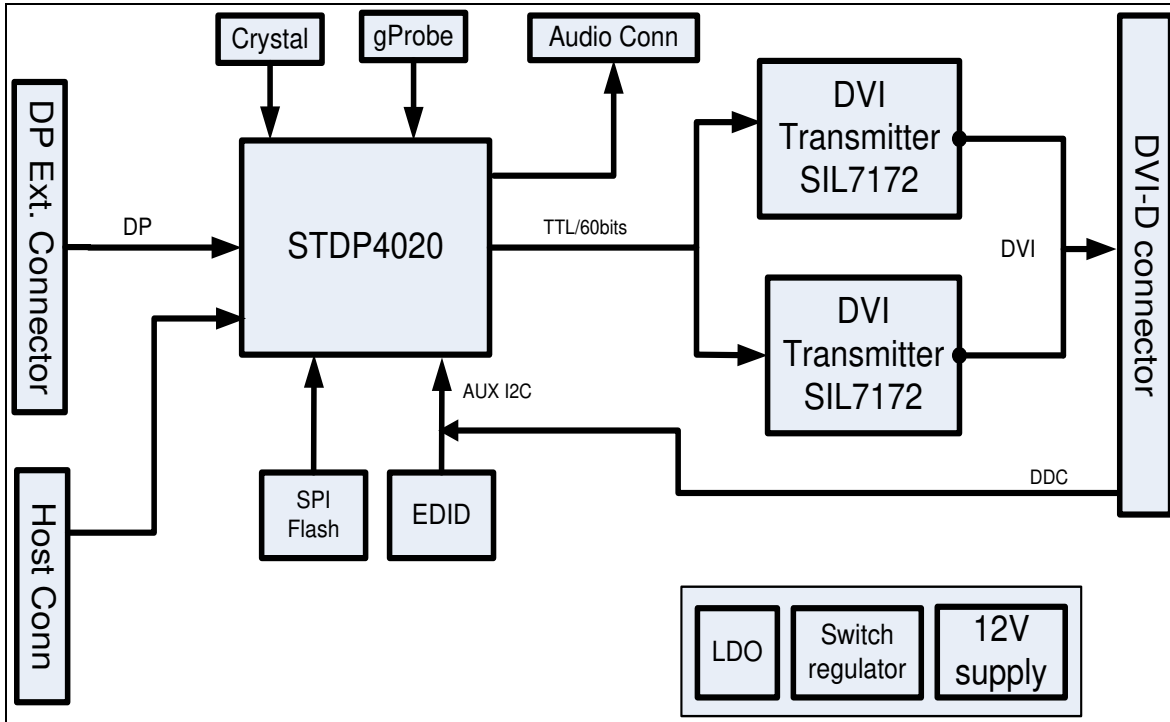
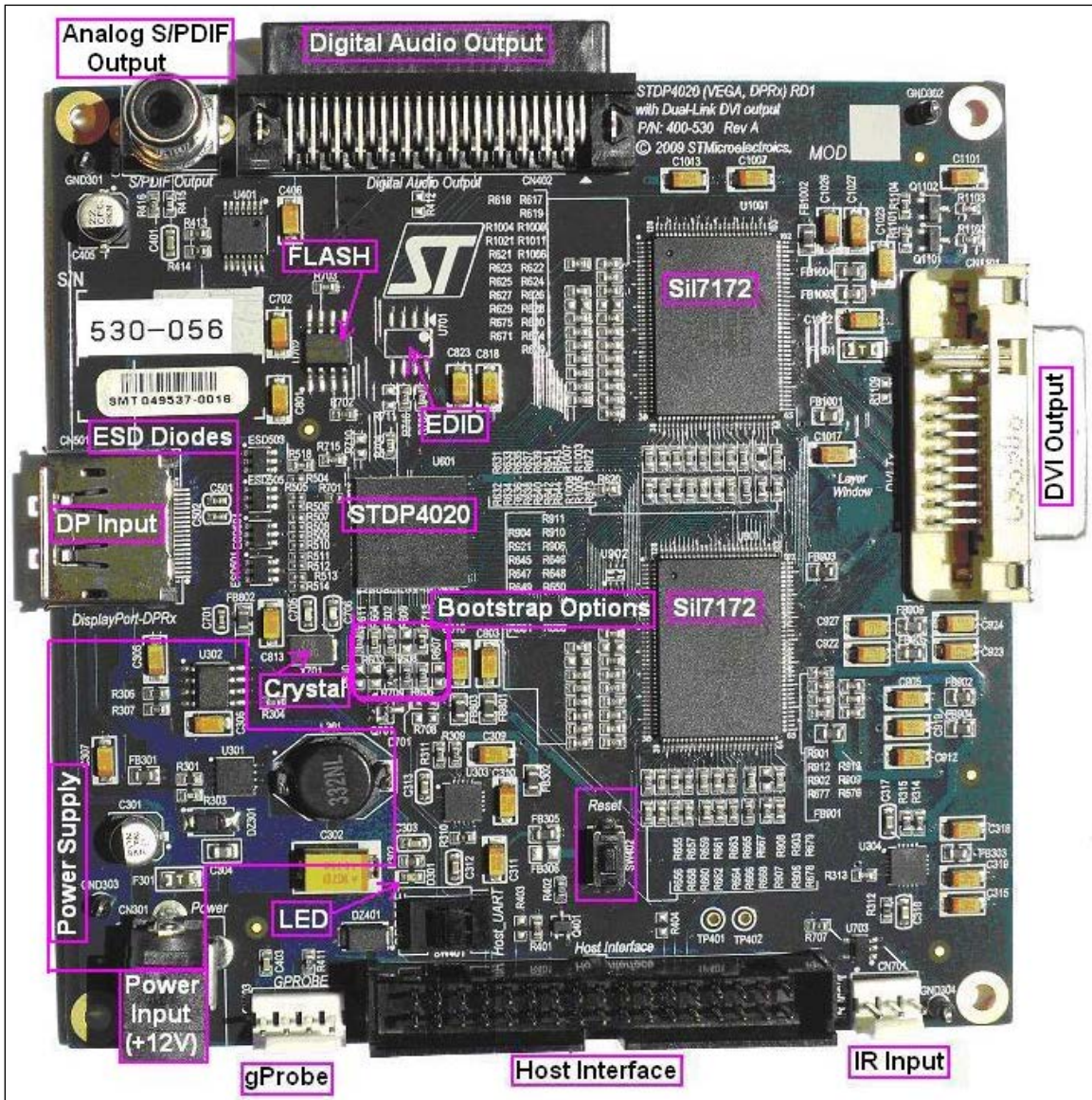



Figure 3. Board picture



## 4.2. Principal components and functions

Below is a summary of all necessary connectors, switches, and other components. Please refer to the latest board schematics for further details.

**Table 1. Principal components and functions**

Label	Description	RefDes
Power Input (+12 V)	Input 12 V, down conversion to 5 V, 3.3 V, and 1.2 V. This board uses a switch regulator for 5 V and an LDO [ <b>low-dropout</b> ] for 3.3 V and 1.2 V. Note the analog and digital supplies (3.3A and 3.3D or 1.2A and 1.2D) are isolated using ferrite beads.	CN301
STDP4020	MegaChips DisplayPort Receiver [STDP4020] is capable of receiving and converting DisplayPort signals into 60-bit LVTTTL output ports that can be mapped to transfer video data either in two pixels per clock or single pixel per clock up to 300 MHz pixel rate. The STDP4020 supports RGB and YCC video color formats with color depth of 12 (YCC 4:2:2 only), 10, and 8 bits.	U601
DP Input	DisplayPort input connector	CN501
Flash	The board includes an SPI Flash of 2 MB to hold the firmware. The SPI Flash can be programmed (ISP) through DP AUX Channel or through UART interface.	U702
DVI Out	DVI output connector	CN1101
Sil7172	Dual-Link DVI transmitters Sil7172	U901,U1001
Digital Audio Output	Digital Audio Output [S/PDIF & I2S in 3.3V logic]: This board supports both compressed and uncompressed audio formats. The extracted audio signal is transferred on a digital audio output bus. This device comprises four I2S audio output ports supporting up to eight channel LPCM audio and a single wire S/PDIF output for encoded audio	CN402
S/PDIF Output	Standard S/PDIF output signal.	CN404
Host Interface	Host Interface (I2C): This board includes a provision to access the STDP4020 device from an external host controller through the Host Interface (I2C port) connection.	CN401
GProbe	GProbe Interface (+3.3 V logic): The board also includes a GProbe connector that connects to the STDP4020 UART port for communication with external PC sources for debug purposes. The MegaChips GProbe tool (software) and PC serial port interface board together create a debug environment for device debug and firmware update. The GProbe interface is also used for ISP purposes.	CN403
Reset	Reset Button, when pressed, triggers a system master reset through the internal reset circuitry. The reset button is used for system reset and debug purposes and is not required for production board design as the STDP4020 produces an internal reset during power ON.	SW402
IR Input	An IR connector for interfacing ST's IR receiver.	CN701
LED	Single LED for indicating the power on status.	D301
Crystal	An external crystal of 27 MHz. The design makes use of internal oscillator circuitry.	X701

Label	Description	RefDes
ESD Diodes	ESD protection diodes for DisplayPort signal (main lanes, AUX and HPD line). The board implements low cost ESD diodes.	ESD501 ESD503 ESD504 ESD505
EDID	EDID Option: Currently not populated to allow pass through.	U701
SW401	Switches UART between Host Interface & GProbe Interface (see mark on PCB).	SW401
Bootstrap Options	The bootstrap options can be configured for: – Single/Dual TTL – IROM/ SPI Flash Refer to the datasheet for more details.	R606 R607 R608 R609

### 4.3. Connector descriptions

The RD1-4020 has the following connectors. The locations of these connectors are shown in the board picture in Figure 3.

**CN301** – +12 V DC 4A Power Input Jack

**CN403** – GProbe Interface (4x1 pin keyed header) connects to the UART port of the STDP4020. Use the MegaChips GProbe board and interface cable for connecting the board to an external PC that has GProbe software running.

<b>Pin 1</b>	+5V
<b>Pin 2</b>	GPROBE_TX
<b>Pin 3</b>	GPROBE_RX
<b>Pin 4</b>	GND

**CN401** – I2C Host Interface (header 17X2) connector for connecting external host. This is used only when an external host controller accesses the DisplayPort receiver; not used for normal operation. In normal operation, internal MCU controls the overall functioning of the DisplayPort receiver (refer to the schematics for complete pin description for the Host Interface).

<b>Pin 1 &amp; 2</b>	+5V
<b>Pin 3 &amp; 4</b>	GND
<b>Pin 5</b>	I2C_SCL
<b>Pin 6</b>	I2C_SDA
<b>Pin 7</b>	HOST_TX
<b>Pin 8</b>	HOST_RX
<b>Pin 9</b>	RESET from Host

Pin 10	NC
Pin 11 & 12	GND
Pin 13	AUX_UART_TX
Pin 14	AUX_UART_RX
Pin 15	AUX_I2C_SCL
Pin 16	AUX_I2C_SDA
Pin 17 & 18	NC
Pin 19 & 20	GND
Pin 21 & 22	NC
Pin 23	IRQ
Pin 24	IR_IN
Pin 25	I2C_MST_SCL
Pin 26	I2C_MST_SDA
Pin 27 & 28	GND
Pin 29 & 30	NC
Pin 31	TP401
Pin 32	NC
Pin 33	TP402
Pin 34	NC

**CN404** – SPDIF output connector.

Pin 1	GND
Pin 2	I2S_0
Pin 3	GND

**CN402** – I2S Digital Audio Output (52 pin) connector. Pinout details are shown below.

Pin A1	NC
Pin A2 & A3	GND
Pin A4 through A6	NC
Pin A7	GND
Pin A8 & A9	NC
Pin A10	I2S_3
Pin A11	I2S_2
Pin A12	I2S_1
Pin A13	NC
Pin A14	I2S_0
Pin A15	R412 / OR / I2S_0
Pin A16 & A17	GND

Pin A18	I2S_MCLK
Pin A19 through A21	NC
Pin A22	I2S_BCLK
Pin A23	+5V
Pin A24	I2S_WCLK
Pin A25 & A26	+5V
Pin B1	GND
Pin B2 & B3	NC
Pin B4 & B5	GND
Pin B6 & B7	NC
Pin B8 & B9	GND
Pin B10 through B13	NC
Pin B14 & B15	GND
Pin B16 through B18	NC
Pin B19 & B20	GND
Pin B21	+12V
Pin B22	NC
Pin B23	+12V
Pin B24	NC
Pin B25	+12V
Pin B26	GND

**CN1101** – Dual-Link DVI-D connector.

Pin 1	DVI_TX2-
Pin 2	DVI_TX2+
Pin 3	GND
Pin 4	DVI_TX4-
Pin 5	DVI_TX4+
Pin 6	AUX_I2C_SCL
Pin 7	AUX_I2C_SDA
Pin 8	NC
Pin 9	DVI_TX1-
Pin 10	DVI_TX1+
Pin 11	GND
Pin 12	DVI_TX3-
Pin 13	DVI_TX3+
Pin 14	+5V
Pin 15	GND
Pin 16	DVI_HPD_DET
Pin 17	DVI_TX0-

<b>Pin 18</b>	DVI_TX0+
<b>Pin 19</b>	GND
<b>Pin 20</b>	DVI_TX5-
<b>Pin 21</b>	DVI_TX5+
<b>Pin 22</b>	GND
<b>Pin 23</b>	DVI_CLK+
<b>Pin 24</b>	DVI_CLK-
<b>Pin C1 through C4</b>	NC
<b>Pin C5 &amp; C6</b>	GND

**CN701** – IR input

<b>Pin 1</b>	GND
<b>Pin 2</b>	+5V
<b>Pin 3</b>	IR_IN

**CN501** – DisplayPort connector

<b>Pin 1</b>	ML_L3N
<b>Pin 2</b>	GND
<b>Pin 3</b>	ML_L3P
<b>Pin 4</b>	ML_L2N
<b>Pin 5</b>	GND
<b>Pin 6</b>	ML_L2P
<b>Pin 7</b>	ML_L1N
<b>Pin 8</b>	GND
<b>Pin 9</b>	ML_L1P
<b>Pin 10</b>	ML_L0N
<b>Pin 11</b>	GND
<b>Pin 12</b>	ML_L0P
<b>Pin 13</b>	GND
<b>Pin 14</b>	GND
<b>Pin 15</b>	+3V3_AVDD/AUX_P
<b>Pin 16</b>	GND
<b>Pin 17</b>	GND / AUX_N
<b>Pin 18</b>	HPD_OUT
<b>Pin 19</b>	GND
<b>Pin 20</b>	+3V3_DVDD



## 4.4. Switches

Host Interface Switch: (SW401): This switch selects the use of GProbe connector or Host Interface connector.

<b>Pin 1</b>	HOST_TX
<b>Pin 2</b>	UART_TX
<b>Pin 3</b>	GPROBE_TX
<b>Pin 4</b>	HOST_RX
<b>Pin 5</b>	UART_RX
<b>Pin 6</b>	GPROBE_RX

## 4.5. Stuffing options

### 4.5.1. Single/dual TTL

**Single TTL configuration:** stuff R609, unstuff R608

**Dual TTL configuration:** stuff R608, unstuff R609

### 4.5.2. IROM/SPI-Flash

**OCM boot from IROM code:** stuff R607, unstuff R606

**OCM boot from external ROM code:** stuff R606, unstuff R607

## 5. Revision history

**Table 2. Document revision history**

Date	Revision	Changes
27-Aug-2010	A	Initial version.
02-Jun-2014	B	Updated to comply with MegaChips documentation style/formatting.

## Notice

Semiconductor products may possibly experience breakdown or malfunction. Adequate care should be taken with respect to the safety design of equipment in order to prevent the occurrence of human injury, fire or social loss in the event of breakdown or malfunction of semiconductor products

The overview of operations and illustration of applications described in this document indicate the conceptual method of use of the semiconductor product and do not guarantee operability in equipment in which the product is actually used.

The names of companies and trademarks stated in this document are registered trademarks of the relevant companies.

MegaChips Co. provides no guarantees nor grants any implementation rights with respect to industrial property rights, intellectual property rights and other such rights belonging to third parties or/and MegaChips Co. in the use of products and of technical information including information on the overview of operations and the circuit diagrams that are described in this document.

The product described in this document may possibly be considered goods or technology regulated by the Foreign Currency and Foreign Trade Control Law. In the event such law applies, export license will be required under said law when exporting the product. This regulation shall be valid in Japan domestic.

In the event the intention is to use the product described in this document in applications that require an extremely high standard of reliability such as nuclear systems, aerospace equipment or medical equipment for life support, please contact the sales department of MegaChips Co. in advance.

All information contained in this document is subject to change without notice.

Copyright © 2014 MegaChips Corporation All rights reserved

## Contact

### **MegaChips Corporation**

#### **Head Quarters**

1-1-1 Miyahara, Yodogawa-ku Osaka 532-0003, Japan  
TEL: +81-6-6399-2884

### **MegaChips Corporation**

#### **Tokyo Office**

17-6 Ichiban-cho, Chiyoda-ku, Tokyo 102-0082, Japan  
TEL: +81-3-3512-5080

### **MegaChips Corporation**

#### **Makuhari Office**

1-3 Nakase Mihama-ku Chiba 261-8501, Japan  
TEL: +81-43-296-7414

### **MegaChips Corporation**

#### **San Jose Office**

2033 Gateway Place, Suite 400, San Jose, CA 95110 U.S.A.  
TEL: +1-408-570-0555

### **MegaChips Corporation**

#### **India Branch**

17th Floor, Concorde Block UB City,  
Vittal Mallya Road, Bangalore 560-001, India  
TEL: +91-80-4041-3999

### **MegaChips Corporation**

#### **Taiwan Branch**

RM. B 2F, Worldwide House, No.129,  
Min Sheng E. Rd., Sec. 3, Taipei 105, Taiwan  
TEL: +886-2-2547-1297

### **MegaChips Corporation**

#### **Tainan Office**

RM. 2, 8F, No.24, Da Qiao 2 Rd., Yong Kang Dist.,  
Tainan 710, Taiwan  
TEL: +886-6-302-2898

### **MegaChips Corporation**

#### **Zhunan Office**

No.118, Chung-Hua Rd., Chu-Nan, Miao-Li 350, Taiwan  
TEL: +886-37-666-156

### **MegaChips Corporation**

#### **Shenzhen Office**

Room 6307, Office Tower, Shun Hing Square, 5002  
Shen Nan Dong Road, Luohu District,  
Shenzhen 518000, P. R. China  
TEL: +86-755-3664-6990