



Chipsmall Limited consists of a professional team with an average of over 10 year of expertise in the distribution of electronic components. Based in Hongkong, we have already established firm and mutual-benefit business relationships with customers from,Europe,America and south Asia,supplying obsolete and hard-to-find components to meet their specific needs.

With the principle of “Quality Parts,Customers Priority,Honest Operation,and Considerate Service”,our business mainly focus on the distribution of electronic components. Line cards we deal with include Microchip,ALPS,ROHM,Xilinx,Pulse,ON,Everlight and Freescale. Main products comprise IC,Modules,Potentiometer,IC Socket,Relay,Connector.Our parts cover such applications as commercial,industrial, and automotives areas.

We are looking forward to setting up business relationship with you and hope to provide you with the best service and solution. Let us make a better world for our industry!



Contact us

Tel: +86-755-8981 8866 Fax: +86-755-8427 6832

Email & Skype: info@chipsmall.com Web: www.chipsmall.com

Address: A1208, Overseas Decoration Building, #122 Zhenhua RD., Futian, Shenzhen, China





Sensors

Xtrinsic MMA865xFC Family

Pin-compatible 12- and 10-bit accelerometers

Typical Applications

- Mobile phones/digital cameras
 - Orientation detection
 - Tap to control
 - Auto wake/sleep for low power consumption
- Tablets/Laptops
 - Anti-theft
 - Tumble and freefall detection
 - Orientation detection
 - Tap detection
- E-Readers
- Remote controls
- E-Compass
- Real-time activity analysis
- Medical activity monitoring

Overview

The Xtrinsic MMA8652FC (12-bit) and MMA8653FC (10-bit) low-power, low-noise accelerometers offer a wide range of performance for portable devices. At only 2 x 2 mm, they have a 56 percent smaller volume than previous Freescale accelerometers, and with a 1 mm height are ideal for low-profile applications.

The MMA865xFC accelerometers have greatly optimized the overall system power consumption to be best in class.

The MMA865xFC 3-axis accelerometers have six user configurable sample rates that can be set over a wide range from 1.5 to 800 samples per second. The operating current is proportional to the sample rate. The power scheme contains normal mode and low-power operational modes. FIFO allows for smarter system power management that contributes over 96 percent savings of the system power consumption when using the i.MX processor.

Xtrinsic MMA865xFC 12-bit/10-bit Accelerometers

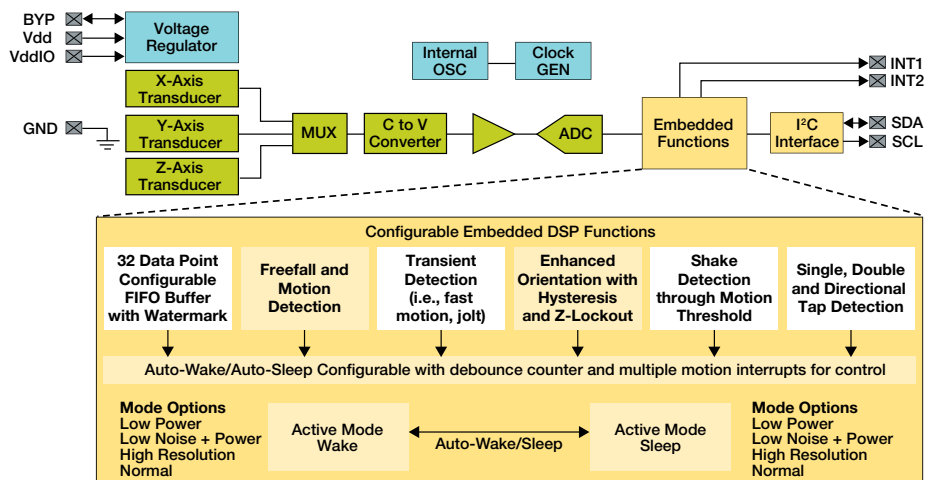

Choose the Right Xtrinsic Accelerometer for Your Design

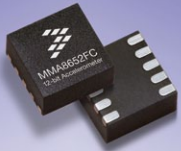

MMA8652FC

- 1 mg/count sensitivity
- Extreme performance
- Rich features
 - P/L detection
 - High pass filter
 - Transient detect

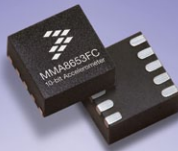

MMA8653FC

- High performance
 - Well rounded
- Cost competitive
- Industry-leading power consumption
- Low-voltage compatibility

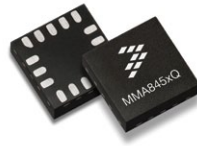

MMA845xQ

- High performance
- Extended features
 - FIFO (14-bit only)
 - Configurable P/L trip angles
 - High pass filter
 - Transient detect

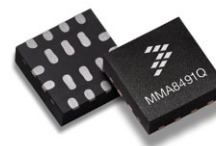

MMA8491Q

- Lowest power
 - 0.35 uA/Hz
- Cost efficient
 - 1 mg/count sensitivity
- Industrial package

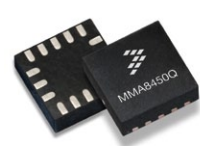

MMA8450Q

- Lowest voltage
 - 1.71–1.89 V

Design Flexibility

Freescale offers a variety of accelerometers with varying features, performance and price points. Our MMA865xFC family of accelerometers is highly versatile to support mid-range applications (12-bit) as well as lower end for basic gestures (10-bit). Whatever your application, there is an Xtrinsic accelerometer optimized for it.

Freescale: A Leader in Sensing Solutions

Expanding on more than 30 years of sensor innovation, Freescale Xtrinsic sensing solutions are designed with the right combination of high-performance sensing capability, processing capacity and customizable software to help deliver smart, differentiated sensing applications. With Xtrinsic sensing solutions, our vision is to offer a diverse and differentiated product portfolio to meet the expanding needs of the automotive, consumer and industrial segments. Xtrinsic solutions offer ideal blends of functionality and intelligence designed to help our customers differentiate and win in highly competitive markets.

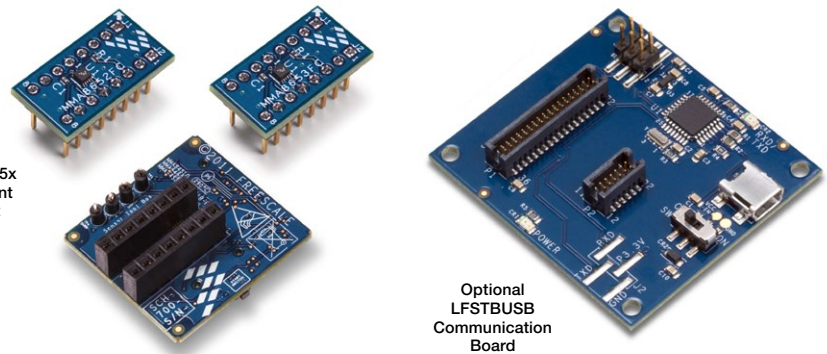

Development Tools

Part Number	Description
LFSTBEB865x	The LFSTBEB865x contains three PCBs: MMA8652FC and MMA8653FC accelerometer daughter cards, and the sensor interface board. Customers can purchase the LFSTBUSB communication board separately.
RDMMMA865x	The RDMMMA865x is a complete kit containing four PCBs: MMA8652FC and MMA8653FC accelerometer daughter cards, sensor interface board and LFSTBUSB communication board for running Freescale sensor toolbox PC software.

Documentation

Document Number	Description
MMA8652FC MMA8653FC	Data sheets
AN4083	Data manipulation and the basic settings for the Xtrinsic MMA865xFC accelerometers

For more information, visit freescale.com/xyz