



Chipsmall Limited consists of a professional team with an average of over 10 year of expertise in the distribution of electronic components. Based in Hongkong, we have already established firm and mutual-benefit business relationships with customers from,Europe,America and south Asia,supplying obsolete and hard-to-find components to meet their specific needs.

With the principle of “Quality Parts,Customers Priority,Honest Operation,and Considerate Service”,our business mainly focus on the distribution of electronic components. Line cards we deal with include Microchip,ALPS,ROHM,Xilinx,Pulse,ON,Everlight and Freescale. Main products comprise IC,Modules,Potentiometer,IC Socket,Relay,Connector.Our parts cover such applications as commercial,industrial, and automotives areas.

We are looking forward to setting up business relationship with you and hope to provide you with the best service and solution. Let us make a better world for our industry!



## Contact us

Tel: +86-755-8981 8866 Fax: +86-755-8427 6832

Email & Skype: info@chipsmall.com Web: www.chipsmall.com

Address: A1208, Overseas Decoration Building, #122 Zhenhua RD., Futian, Shenzhen, China



## CMOS Ionization Smoke Detector ASIC with Interconnect, Timer Mode and Alarm Memory

### Features

- Pin Selectable Horn Patterns
- Alarm Memory
- Sensitivity Control Timer:
  - 8 minute Timer for RE46C162
  - 1 minute Timer for RE46C163
- >1500V ESD Protection (HBM) on All Pins
- Guard Outputs for Ion Detector Input
- $\pm 0.75$  pA Detect Input Current
- Internal Reverse Battery Protection
- Low Quiescent Current Consumption ( $< 6.5$   $\mu$ A)
- I/O Filter and Charge Dump
- Internal Low Battery Detection
- Power-up Low Battery Test
- Interconnect up to 66 Detectors
- RoHS Compliant, Lead Free Packaging

### Description

The RE46C162/163 devices are low-power, CMOS ionization type, smoke detector ICs. With few external components, these circuits will provide all the required features for an ionization type smoke detector.

An internal oscillator strobes power to the smoke detection circuitry for 10.5 ms every 1.67 seconds to keep standby current to a minimum. A check for a low battery condition is performed every 40 seconds when in standby. The temporal horn pattern supports the NFPA 72 emergency evacuation signal.

An interconnect pin allows multiple detectors to be connected so when one unit alarms, all units will sound. A charge dump feature will quickly discharge the interconnect line when exiting a local alarm. The interconnect input is also digitally filtered.

An internal timer allows for a single button, push-to-test to be used for a reduced sensitivity mode.

An alarm memory feature allows the user to determine if the unit has previously entered a local alarm condition.

Utilizing low-power CMOS technology, the RE46C162/163 devices are designed for use in smoke detectors that comply with Underwriters Laboratory Specification UL217 and UL268.

### Package Types

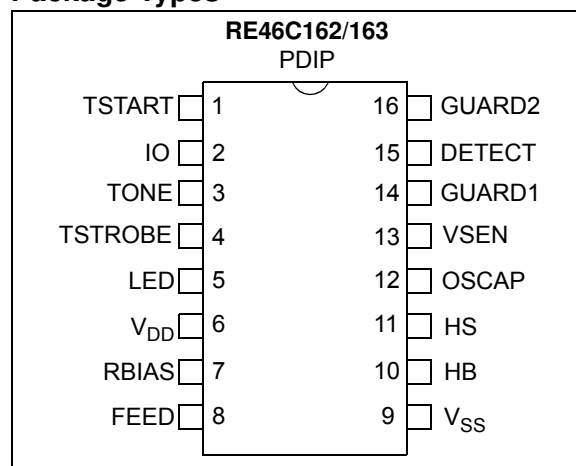

# RE46C162/163

## Functional Block Diagram

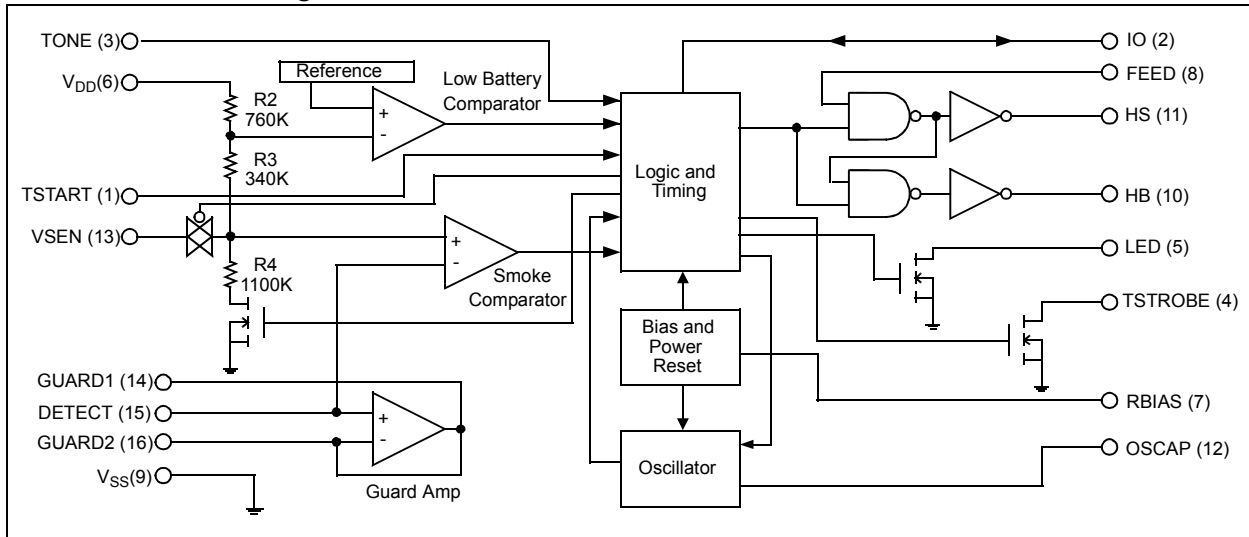

## Typical Applications

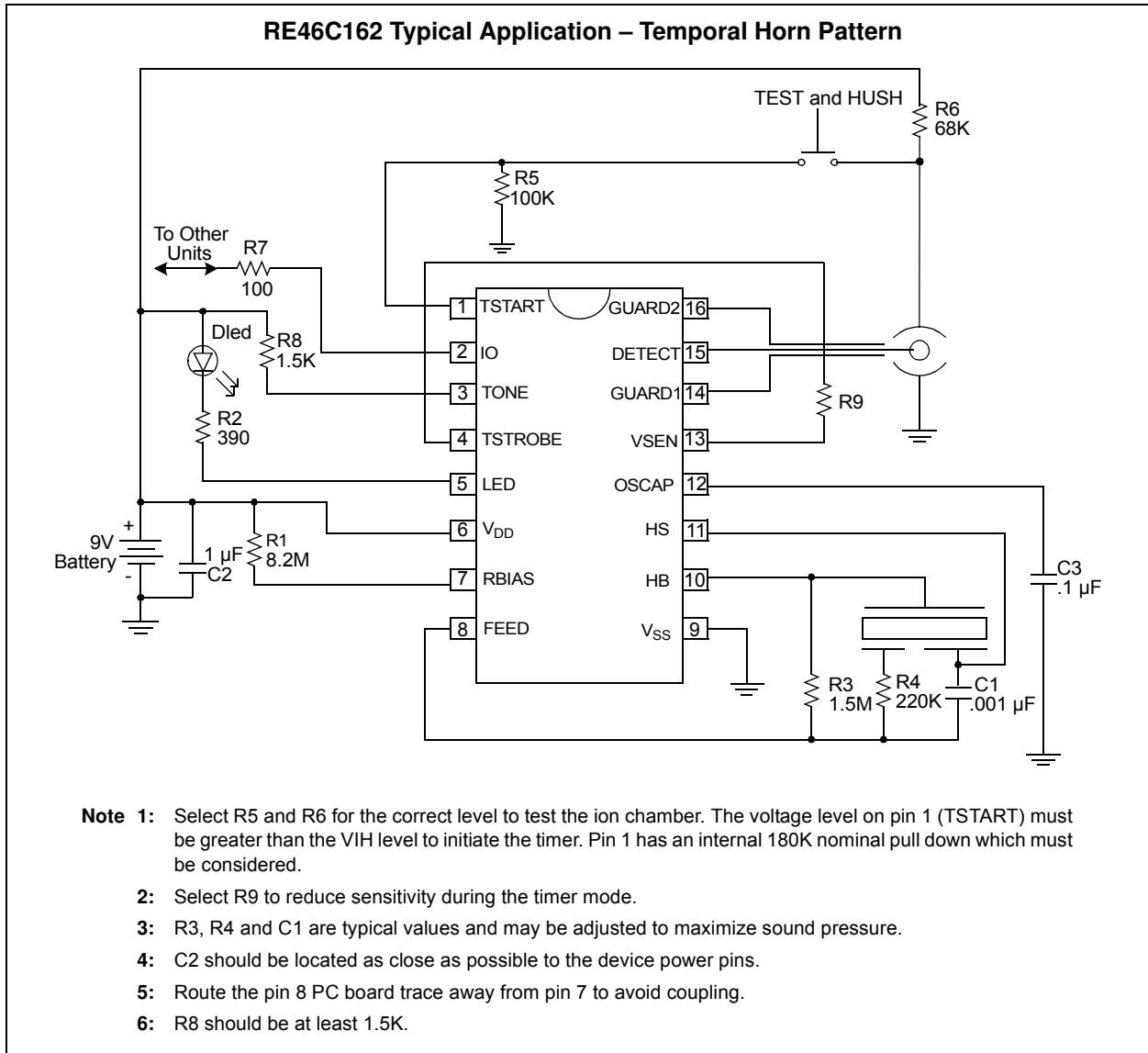

# RE46C162/163

## RE46C162 Typical Application – 2/3 Duty Cycle Continuous Tone Horn Pattern

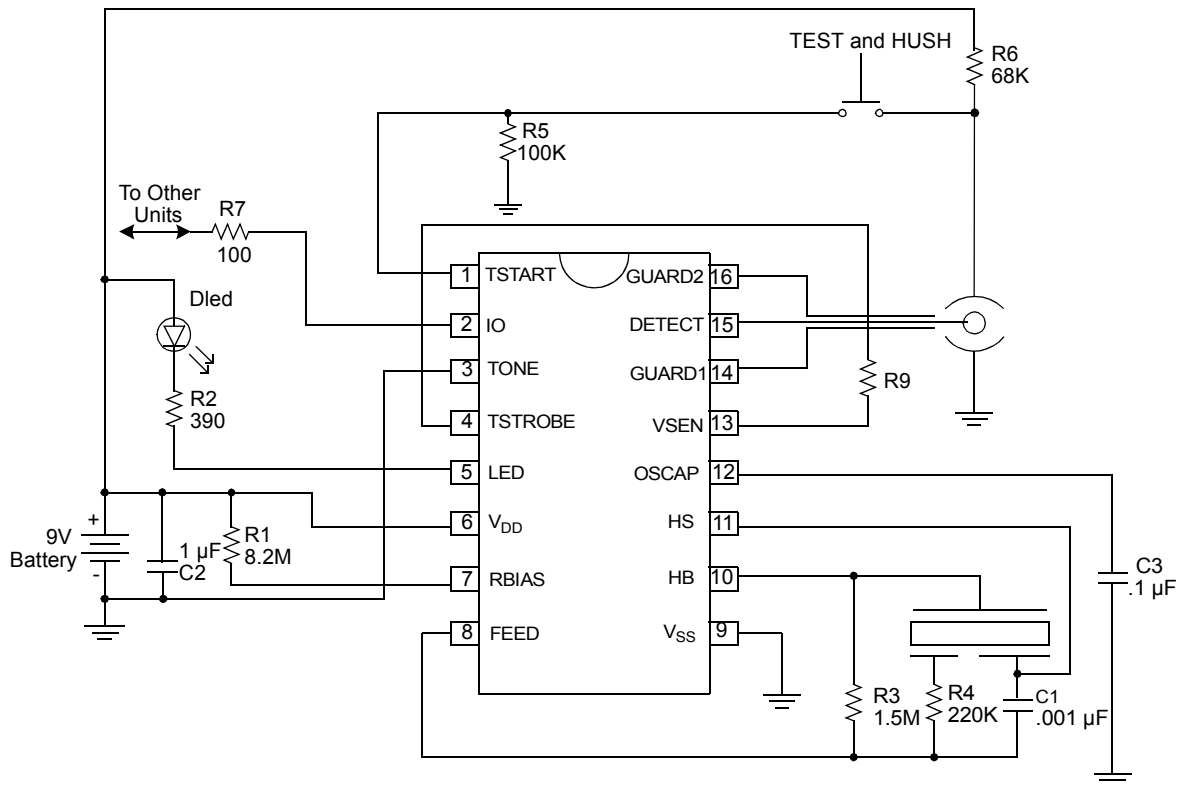

- Note 1:** Select R5 and R6 for the correct level to test the ion chamber. The voltage level on pin 1 (TSTART) must be greater than the VIH level to initiate the timer. Pin 1 has an internal 180K nominal pull down which must be considered.
- 2:** Select R9 to reduce sensitivity during the timer mode.
- 3:** R3, R4 and C1 are typical values and may be adjusted to maximize sound pressure.
- 4:** C2 should be located as close as possible to the device power pins.
- 5:** Route the pin 8 PC board trace away from pin 7 to avoid coupling.

## 1.0 ELECTRICAL CHARACTERISTICS

### Absolute Maximum Ratings†

V <sub>DD</sub> .....	15V
Input Voltage Range Except FEED, I/O.....	V <sub>IN</sub> =-.3V to V <sub>DD</sub> +.3V
FEED Input Voltage Range.....	V <sub>INFD</sub> = -10 to +22V
I/O Input Voltage Range.....	V <sub>IO1</sub> = -.3 to 15V
Reverse Battery Time.....	T <sub>RB</sub> = 5S
Input Current except FEED.....	I <sub>IN</sub> = 10 mA
Operating Temperature.....	T <sub>A</sub> = -10 to +60°C
Storage Temperature.....	T <sub>STG</sub> = -55 to +125°C
Maximum Junction Temperature.....	T <sub>J</sub> = +150°C

† **Notice:** Stresses above those listed under "Maximum ratings" may cause permanent damage to the device. This is a stress rating only and functional operation of the device at these or any other conditions above those indicated in the operation listings of this specification is not implied. Exposure to maximum rating conditions for extended periods may affect device reliability.

### DC ELECTRICAL CHARACTERISTICS

**DC Electrical Characteristics:** Unless otherwise indicated, all parameters apply at T<sub>A</sub> = +25°C, V<sub>DD</sub> = 9V, OSCAP = .1 μF, R<sub>BIAS</sub> = 8.2 MΩ, V<sub>SS</sub> = 0V

Parameter	Symbol	Test Pin	Min	Typ	Max	Units	Conditions
Supply Voltage	V <sub>DD</sub>	6	6	—	12	V	Operating
Supply Current	I <sub>DD1</sub>	6	—	5	6.5	μA	R <sub>BIAS</sub> = 8.2 MW, OSCAP = .1 μF
	I <sub>DD2</sub>	6	—	—	9	μA	R <sub>BIAS</sub> = 8.2 MW, OSCAP = .1 μF; V <sub>DD</sub> = 12V
Input Voltage High	V <sub>IH1</sub>	3,8	6.2	4.5	—	V	<b>Note 2</b>
	V <sub>IH2</sub>	2	3	—	—	V	No local alarm, I/O as an input
	V <sub>IH3</sub>	1	4.5	—	—	V	
Input Voltage Low	V <sub>IL1</sub>	3,8	—	4.5	2.7	V	<b>Note 2</b>
	V <sub>IL2</sub>	2	—	—	1	V	No local alarm, I/O as an input
	V <sub>IL3</sub>	1	—	—	2.5	V	
Input Leakage Low	I <sub>LDET1</sub>	15	—	—	-0.75	pA	V <sub>DD</sub> = 9V, DETECT = V <sub>SS</sub> , 0-40% RH
	I <sub>LDET2</sub>	15	—	—	-1.50	pA	V <sub>DD</sub> = 9V, DETECT = V <sub>SS</sub> , 85% RH <b>Note 1</b>
	I <sub>LFD</sub>	8	—	—	-50	μA	FEED = -10V
	I <sub>L TONE</sub>	3	—	—	-100	nA	TONE = V <sub>SS</sub>
Input Leakage High	I <sub>HDET1</sub>	15	—	—	0.75	pA	V <sub>DD</sub> = 9V, DETECT = V <sub>DD</sub> , 0-40% RH
	I <sub>HDET2</sub>	15	—	—	1.50	pA	V <sub>DD</sub> = 9V, DETECT = V <sub>DD</sub> , 85% RH <b>Note 1</b>
	I <sub>HFD</sub>	8	—	—	50	μA	FEED = 22V
	I <sub>IOL2</sub>	2	—	—	150	μA	No alarm, V <sub>IO</sub> = 15V
	I <sub>H TONE</sub>	3	—	—	100	nA	TONE = V <sub>DD</sub>
Output Off Leakage High	I <sub>IOHZ</sub>	4,5	—	—	1	μA	Outputs off
Input Pull Down Current	I <sub>PD1</sub>	1	20	50	80	μA	TSTART = 9V
Output High Voltage	V <sub>OH1</sub>	10,11	6.3	—	—	V	I <sub>OH</sub> = -16 mA, V <sub>DD</sub> = 7.2V

- Note 1:** Sample test only.  
**Note 2:** Not 100% production tested.  
**Note 3:** Production test at room with temperature guard banded limits.

# RE46C162/163

## DC ELECTRICAL CHARACTERISTICS (CONTINUED)

**DC Electrical Characteristics:** Unless otherwise indicated, all parameters apply at  $T_A = +25^\circ\text{C}$ ,  $V_{DD} = 9\text{V}$ ,  $\text{OSCAP} = .1 \mu\text{F}$ ,  $\text{RBIAS} = 8.2 \text{M}\Omega$ ,  $V_{SS} = 0\text{V}$

Parameter	Symbol	Test Pin	Min	Typ	Max	Units	Conditions
Output Low Voltage	$V_{OL1}$	10,11	—	—	.9	V	$I_{OL} = 16 \text{mA}$ , $V_{DD} = 7.2\text{V}$
	$V_{OL2}$	4	—	—	.5	V	$I_{OL} = 500 \mu\text{A}$
	$V_{OL3}$	5	—	—	1	V	$I_{OL} = 10 \text{mA}$ , $V_{DD} = 7.2\text{V}$
Output Current	$I_{IOL1}$	2	25	—	60	$\mu\text{A}$	No alarm, $V_{IO} = V_{DD} - 2\text{V}$
	$I_{IOH1}$	2	-4	—	-16	mA	Alarm, $V_{IO} = V_{DD} - 2\text{V}$ or $V_{IO} = 0\text{V}$
	$I_{IODMP}$	2	5	—	—	mA	At conclusion of local alarm or test, $V_{IO} = 1\text{V}$
Low Battery Voltage	$V_{LB}$	6	7.2	7.5	7.8	V	$T_A = -10$ to $+60^\circ\text{C}$ , <b>Note 3</b>
Internal Sensitivity Set Voltage	$V_{SET1}$	13	48.5	50	51.5	$\%V_{DD}$	
Offset Voltage	$V_{GOS1}$	14,15	-50	—	50	mV	Guard amplifier
	$V_{GOS2}$	15,16	-50	—	50	mV	Guard amplifier
	$V_{GOS3}$	13,15	-50	—	50	mV	Smoke comparator
Common Mode Voltage	$V_{CM1}$	14,15	2	—	$V_{DD} - .5$	V	Guard amplifier, <b>Note 2</b>
	$V_{CM2}$	13,15	.5	—	$V_{DD} - 2$	V	Smoke comparator, <b>Note 2</b>
Output Impedance	$Z_{OUT}$	14,16	—	10	—	k $\Omega$	Guard amplifier outputs, <b>Note 2</b>
Hysteresis	$V_{HYS}$	13	90	130	170	mV	No alarm to alarm condition

**Note 1:** Sample test only.

**Note 2:** Not 100% production tested.

**Note 3:** Production test at room with temperature guard banded limits.

## AC ELECTRICAL CHARACTERISTICS

**AC Electrical Characteristics:** Unless otherwise indicated, all parameters apply at  $T_A = +25^\circ\text{C}$ ,  $V_{DD} = 9\text{V}$ ,  $\text{OSCAP} = .1 \mu\text{F}$ ,  $\text{RBIAS} = 8.2 \text{M}\Omega$ ,  $V_{SS} = 0\text{V}$ .

Parameter	Symbol	Test Pin	Min	Typ	Max	Units	Conditions
Oscillator Period	$T_{PER1}$	12	1.34	1.67	2	s	No alarm condition
	$T_{PER2}$	12	37.5	41.7	45.8	ms	Alarm condition
Oscillator Pulse Width	$T_{PW}$	5	9.4	10.5	12.9	ms	Operating
LED On Time	$T_{LON}$	5	9.4	10.5	12.9	ms	Operating
LED Off Time	$T_{LOF1}$	5	32	40	48	s	Standby, no alarm
	$T_{LOF2}$	5	.9	1	1.1	s	Alarm condition
	$T_{LOF3}$	5	8	10	12	s	Timer mode, no alarm
	$T_{LOF4}$	5	2.66	3.33	4	s	Alarm memory LED pulse spacing
	$T_{LOF5}$	5	26	33.3	40	s	Alarm memory LED off time between pulse train

**Note 1:** See timing diagram for horn temporal and non-temporal patterns.

**Note 2:**  $T_{PER1}$ ,  $T_{PER2}$  and  $T_{PW}$  are 100% production tested. All other timing is verified by functional testing.

## AC ELECTRICAL CHARACTERISTICS (CONTINUED)

**AC Electrical Characteristics:** Unless otherwise indicated, all parameters apply at  $T_A = +25^\circ\text{C}$ ,  $V_{DD} = 9\text{V}$ ,  $\text{OSCAP} = .1 \mu\text{F}$ ,  $\text{RBIAS} = 8.2 \text{M}\Omega$ ,  $V_{SS} = 0\text{V}$ .

Parameter	Symbol	Test Pin	Min	Typ	Max	Units	Conditions	
Horn On Time	$T_{\text{HON1}}$	10,11	450	500	550	ms	Operating, alarm condition, <b>Note 1</b> , TONE = High	
	$T_{\text{HON2}}$	10,11	9.4	10.5	12.9	ms	Low battery, no alarm or PTT in alarm memory	
	$T_{\text{HON3}}$	10,11	150	167	183	ms	Operating, alarm condition, <b>Note 1</b> , TONE = Low	
Horn Off Time	$T_{\text{HOF1}}$	10,11	450	500	550	ms	Operating, alarm condition, <b>Note 1</b> , TONE = High	
	$T_{\text{HOF2}}$	10,11	1.35	1.5	1.65	s	Operating, alarm condition, <b>Note 1</b> , TONE = High	
	$T_{\text{HOF3}}$	10,11	75	83	92	ms	Operating, alarm condition, <b>Note 1</b> , TONE = Low	
	$T_{\text{HOF4}}$	10,11	32	40	48	s	Low battery, no alarm	
	$T_{\text{HOF5}}$	10,11	216	240	264	ms	PTT in alarm memory	
I/O Charge Dump Duration	$T_{\text{IODMP}}$	2	1.34	1.67	2.0	s	At conclusion of local alarm or test	
I/O Delay	$T_{\text{IODLY1}}$	2	—	3	—	s	From start of local alarm to I/O active	
I/O Filter	$T_{\text{IOFILT}}$	2	—	—	450	ms	I/O as input, no local alarm	
Remote Alarm Delay	$T_{\text{IODLY2}}$	2	.450	—	2.75	s	No local alarm, I/O as input, from I/O active to horn active	
Timer Period	RE46C162	$T_{\text{TPER}}$	4	6	8	10	Min	No alarm
	RE46C163		4	40	50	60	s	No alarm
Alarm Memory Visual Indicator Period	$T_{\text{AMTPER}}$	5	19.2	24	28.8	Hour	No alarm, alarm memory	

**Note 1:** See timing diagram for horn temporal and non-temporal patterns.

**2:**  $T_{\text{PER1}}$ ,  $T_{\text{PER2}}$  and  $T_{\text{PW}}$  are 100% production tested. All other timing is verified by functional testing.

## TEMPERATURE CHARACTERISTICS

Electrical Specifications: Unless otherwise indicated,

Parameters	Sym	Min	Typ	Max	Units	Conditions
<b>Temperature Ranges</b>						
Operating Temperature Range	$T_A$	-10	—	+60	$^\circ\text{C}$	
Storage Temperature Range	$T_{\text{STG}}$	-55	—	+125	$^\circ\text{C}$	
<b>Thermal Package Resistances</b>						
Thermal Resistance, 16L-PDIP	$\theta_{\text{JA}}$	—	70	—	$^\circ\text{C/W}$	



# RE46C162/163

---

NOTES:

## 2.0 PIN DESCRIPTIONS

The descriptions of the pins are listed in [Table 2-1](#).

**TABLE 2-1: PIN FUNCTION TABLE**

RE46C162/163	Name	Description
PDIP, SOIC		
1	TSTART	This input is used to invoke the push-to-test alarm, alarm memory indication, and the timer mode. This input has an internal pull-down.
2	I/O	This bidirectional pin provides the capability to interconnect many detectors in a single system. This pin has an internal pull-down.
3	TONE	This pin selects the NFPA72 horn tone (high) or the 2/3 duty cycle continuous tone (low).
4	TSTROBE	This pin is strobed on with the internal clock in timer mode. A resistor connected to this pin is used to modify the detector sensitivity for the timer period.
5	LED	Open drain NMOS output used to drive a visible LED.
6	V <sub>DD</sub>	Connect to the positive supply voltage.
7	RBIAS	A resistor connected between this pin and V <sub>DD</sub> sets the internal bias current.
8	FEED	Usually connected to the feedback electrode through a current limiting resistor. If not used, this pin must be connected to V <sub>DD</sub> or V <sub>SS</sub> .
9	V <sub>SS</sub>	Connect to the negative supply voltage.
10	HB	This pin is connected to the metal electrode of a piezoelectric transducer.
11	HS	HS is a complementary output to HB and connects to the ceramic electrode of the piezoelectric transducer.
12	OSCAP	A capacitor connected between this pin and V <sub>SS</sub> sets the oscillator timing.
13	VSEN	This pin can be used to modify the set point for the smoke comparator by use of external resistors to V <sub>DD</sub> or V <sub>SS</sub> .
14	GUARD1	Output of the guard amplifier.
15	DETECT	Connect to the collector electrode (CEV) of the ion smoke chamber.
16	GUARD2	Output of the guard amplifier.

# RE46C162/163

---

NOTES:

## 3.0 DEVICE DESCRIPTION

### 3.1 Internal Timing

With external components as indicated on the application drawing, the period of the oscillator is nominally 1.67 seconds in standby. Every 1.67 seconds, the detection circuitry is powered up for 10.5 ms and the status of the smoke comparator is latched. In addition, every 40 seconds the LED driver is turned on for 10.5 ms and the status of the low battery comparator is latched. The smoke comparator status is not checked during the low battery test, during the low battery horn warning chirp, or when the horn is on due to an alarm condition.

If an alarm condition is detected, the oscillator period increases to 41.7 ms.

Due to the low current used in the oscillator, the capacitor on the OSCAP pin should be a low leakage type.

### 3.2 Smoke Detection Circuit

The smoke comparator compares the ionization chamber voltage to a voltage derived from a resistor divider across  $V_{DD}$ . This divider voltage is available externally on the VSEN pin. When smoke is detected, this voltage is internally increased by 130 mV nominal to provide hysteresis and make the detector less sensitive to false triggering.

The VSEN pin can be used to modify the internal set point for the smoke comparator by use of external resistors to  $V_{DD}$  or  $V_{SS}$ . Nominal values for the internal resistor divider are indicated on the block diagram. These internal resistor values can vary by up to  $\pm 20\%$ , but the resistor matching should be  $< 2\%$  on any one device. The transmission switch on VSEN prevents any interaction from the external adjustment resistors.

The guard amplifier and outputs are always active and will be within 50 mV of the DETECT input to reduce surface leakage. The guard outputs also allow for measurement of the DETECT input without loading the ionization chamber.

### 3.3 Low Battery Detection

An internal reference is compared to the voltage-divided  $V_{DD}$  supply. The battery can be checked under load via the LED low side driver output since low battery status is latched at the end of the 10.5 ms LED pulse.

### 3.4 LED Pulse

The LED is pulsed on for 10.5 ms every 40s in standby. In alarm, the LED is pulsed on for 10.5 ms every 1 second.

### 3.5 Interconnect

The I/O pin provides a capability common to many detectors in a single system. If a single unit goes into alarm, the I/O pin is driven high. This high signal causes the interconnected units to alarm. The LED flashes every 1s for 10.5 ms on the signaling unit and is inhibited on the units that are in alarm due to the I/O signal. An internal sink device on the I/O pin helps to discharge the interconnect line. This charge dump device is active for 1 clock cycle after the unit exits the alarm condition (1.67s).

The interconnect input has a 500 ms nominal digital filter. This allows for interconnection to other types of alarms (carbon monoxide for example) that may have a pulsed interconnect signal.

### 3.6 Testing

At power-up all internal registers are reset. The low battery set point can be tested at power-up by holding FEED and OSCAP low at power-up. HB will change state as  $V_{DD}$  passes through the low battery set point. By holding the OSCAP pin low, the internal power strobe is active. Functional testing can be accelerated by driving OSCAP with a 4 kHz square wave; however, the 10.5 ms strobe period must be maintained for proper operation of the analog circuitry. Refer to [Figure 3-1](#) timing diagram.

### 3.7 Timer Mode

The transition of the TSTART pin from a high to low level initiates a timer period (10 minutes maximum for RE46C162, and 1 minute maximum for RE46C163). During this timer period, the open drain NMOS on the TSTROBE pin is strobed simultaneously with the internal clock. A resistor connected to this pin and the VSEN pin is used to modify the detector sensitivity for the timer period.

During the timer period, the LED flashes for 10.5 ms every 10 seconds.

If the smoke level exceeds the reduced sensitivity set point during the timer period, the unit will go into a local alarm condition, the horn will sound and the timer mode is cancelled. If an external only alarm occurs during the timer mode, the timer mode is cancelled.

If the test button is pushed in a standby, reduced sensitivity mode, the unit is tested normally. Upon release of the test button, the timer mode counter is reset and restarted.

# RE46C162/163

## 3.8 Alarm Memory

If a detector has entered a local alarm, once it exits the local alarm, the alarm memory latch is set. Initially the LED can be used to visually identify any unit that had previously been in a local alarm condition. The LED will flash 3 times spaced 3.3 seconds apart. This pattern will repeat every 40 seconds. The duration of the flash is 10.5 ms. In order to conserve battery power, this visual indication will stop after a period of 24 hours. The user will still be able to identify a unit with an active alarm memory by pressing the push-to-test button. When the push-to-test button is active, the horn will chirp for 10.5 ms every 250 ms.

If the alarm memory condition is set, any time the push-to-test button is pressed and then released, the alarm memory latch is reset.

The initial 24 hour visual indication is not displayed if a low battery condition exists.

## 3.9 Tone Select

The TONE pin selects the NFPA72 temporal horn tone (high), or the 2/3 duty cycle continuous tone (low). If this pin is externally connected high, use a current limiting resistor of at least 1.5K from TONE pin to  $V_{DD}$ .

## 3.10 Reverse Battery Protection

The RE46C162/163 internally limits the current from  $V_{SS}$  to  $V_{DD}$  in the event of accidental polarity reversal. If an input is connected to  $V_{DD}$  it should be done through a resistance of at least 1.5K to limit the reverse current through this path.

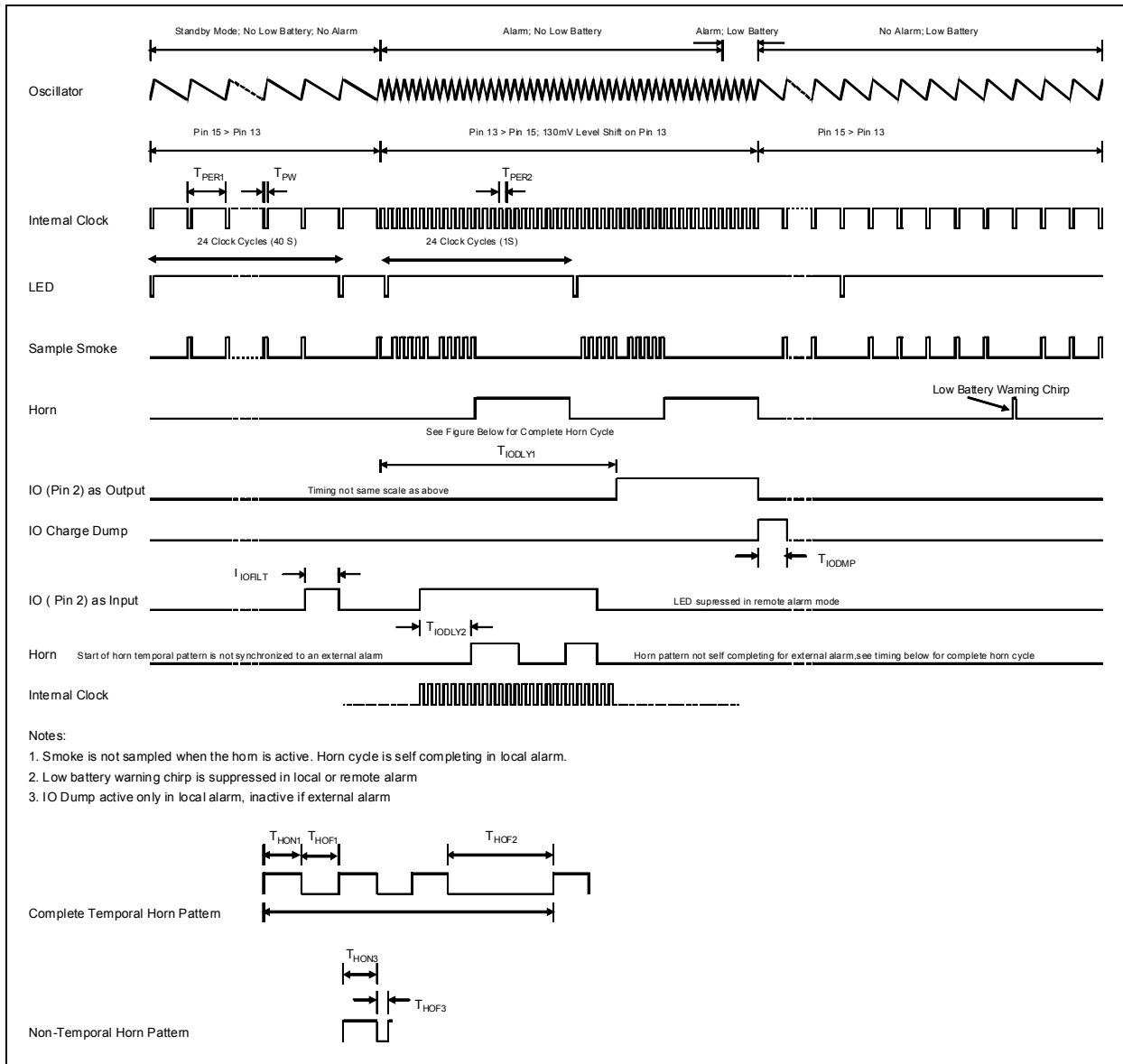
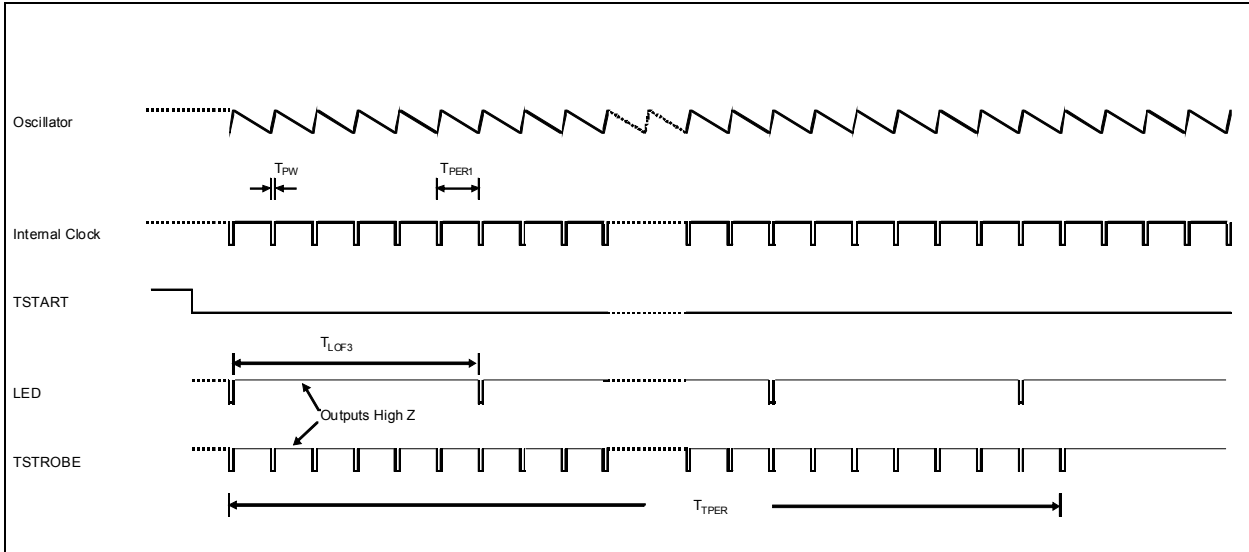
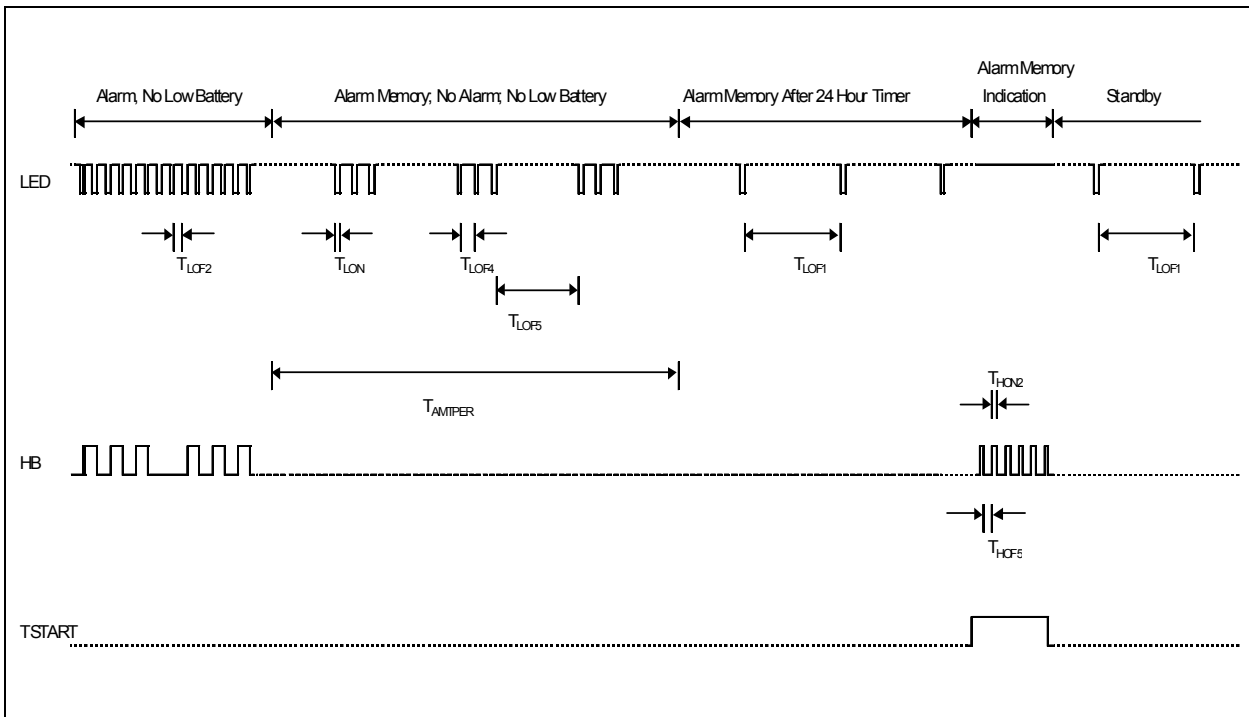

FIGURE 3-1: Timing Diagram – Standby, Local Alarm, Low Battery.



**FIGURE 3-2:** Timing Diagram – Timer Mode.



**FIGURE 3-3:** Timing Diagram – Alarm Memory Mode.

# RE46C162/163

---

NOTES:

## 4.0 PACKAGING INFORMATION

### 4.1 Package Marking Information

16-Lead PDIP

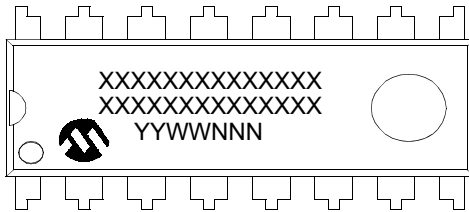

Example

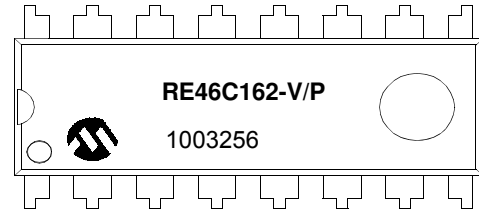

<b>Legend:</b>	XX...X	Customer-specific information
	Y	Year code (last digit of calendar year)
	YY	Year code (last 2 digits of calendar year)
	WW	Week code (week of January 1 is week '01')
	NNN	Alphanumeric traceability code
	(e3)	Pb-free JEDEC designator for Matte Tin (Sn)
	*	This package is Pb-free. The Pb-free JEDEC designator (e3) can be found on the outer packaging for this package.

**Note:** In the event the full Microchip part number cannot be marked on one line, it will be carried over to the next line, thus limiting the number of available characters for customer-specific information.



# RE46C162/163

## 16-Lead Plastic Dual In-Line (P) – 300 mil Body [PDIP]

**Note:** For the most current package drawings, please see the Microchip Packaging Specification located at <http://www.microchip.com/packaging>

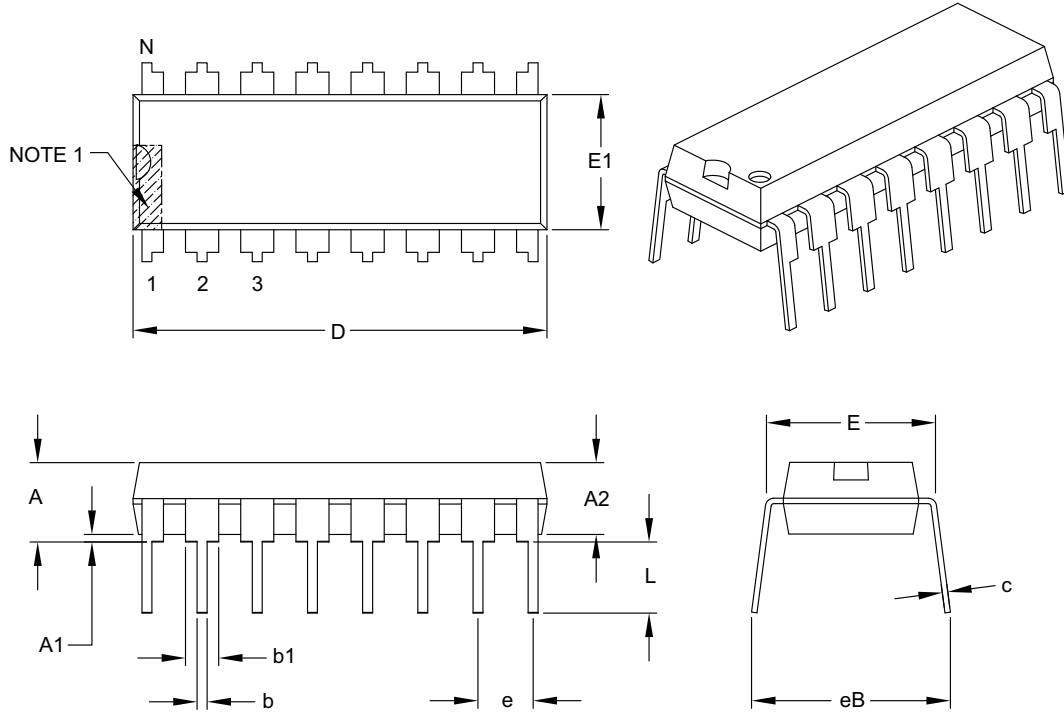

Dimension Limits	Units	INCHES		
		MIN	NOM	MAX
Number of Pins	N	16		
Pitch	e	.100 BSC		
Top to Seating Plane	A	–	–	.210
Molded Package Thickness	A2	.115	.130	.195
Base to Seating Plane	A1	.015	–	–
Shoulder to Shoulder Width	E	.290	.310	.325
Molded Package Width	E1	.240	.250	.280
Overall Length	D	.735	.755	.775
Tip to Seating Plane	L	.115	.130	.150
Lead Thickness	c	.008	.010	.015
Upper Lead Width	b1	.045	.060	.070
Lower Lead Width	b	.014	.018	.022
Overall Row Spacing §	eB	–	–	.430

**Notes:**

- Pin 1 visual index feature may vary, but must be located within the hatched area.
- § Significant Characteristic.
- Dimensions D and E1 do not include mold flash or protrusions. Mold flash or protrusions shall not exceed .010" per side.
- Dimensioning and tolerancing per ASME Y14.5M.

BSC: Basic Dimension. Theoretically exact value shown without tolerances.

Microchip Technology Drawing C04-017B

## APPENDIX A: REVISION HISTORY

### Revision A (March 2010)

- Original Release of this Document.

# RE46C162/163

---

NOTES:

## PRODUCT IDENTIFICATION SYSTEM

To order or obtain information, e.g., on pricing or delivery, refer to the factory or the listed sales office.

<u>PART NO.</u>	<u>/X</u>	<u>XX</u>	
Device	Package	Number of Pins	
Device			RE46C162: CMOS Ionization Smoke Detector RE46C163: CMOS Ionization Smoke Detector
Package	E	=	Plastic Dual In-Line, 300 mil. Body, 16-Lead (PDIP)

**Examples:**

- a) RE46C162E16F: 16LD PDIP Package.
- b) RE46C163E16F: 16LD PDIP Package.

# RE46C162/163

---

NOTES:

---

**Note the following details of the code protection feature on Microchip devices:**

- Microchip products meet the specification contained in their particular Microchip Data Sheet.
- Microchip believes that its family of products is one of the most secure families of its kind on the market today, when used in the intended manner and under normal conditions.
- There are dishonest and possibly illegal methods used to breach the code protection feature. All of these methods, to our knowledge, require using the Microchip products in a manner outside the operating specifications contained in Microchip's Data Sheets. Most likely, the person doing so is engaged in theft of intellectual property.
- Microchip is willing to work with the customer who is concerned about the integrity of their code.
- Neither Microchip nor any other semiconductor manufacturer can guarantee the security of their code. Code protection does not mean that we are guaranteeing the product as "unbreakable."

Code protection is constantly evolving. We at Microchip are committed to continuously improving the code protection features of our products. Attempts to break Microchip's code protection feature may be a violation of the Digital Millennium Copyright Act. If such acts allow unauthorized access to your software or other copyrighted work, you may have a right to sue for relief under that Act.

---

Information contained in this publication regarding device applications and the like is provided only for your convenience and may be superseded by updates. It is your responsibility to ensure that your application meets with your specifications. MICROCHIP MAKES NO REPRESENTATIONS OR WARRANTIES OF ANY KIND WHETHER EXPRESS OR IMPLIED, WRITTEN OR ORAL, STATUTORY OR OTHERWISE, RELATED TO THE INFORMATION, INCLUDING BUT NOT LIMITED TO ITS CONDITION, QUALITY, PERFORMANCE, MERCHANTABILITY OR FITNESS FOR PURPOSE. Microchip disclaims all liability arising from this information and its use. Use of Microchip devices in life support and/or safety applications is entirely at the buyer's risk, and the buyer agrees to defend, indemnify and hold harmless Microchip from any and all damages, claims, suits, or expenses resulting from such use. No licenses are conveyed, implicitly or otherwise, under any Microchip intellectual property rights.

**Trademarks**

The Microchip name and logo, the Microchip logo, dsPIC, KEELOQ, KEELOQ logo, MPLAB, PIC, PICmicro, PICSTART, PIC<sup>32</sup> logo, rPIC and UNI/O are registered trademarks of Microchip Technology Incorporated in the U.S.A. and other countries.

FilterLab, Hampshire, HI-TECH C, Linear Active Thermistor, MXDEV, MXLAB, SEEVAL and The Embedded Control Solutions Company are registered trademarks of Microchip Technology Incorporated in the U.S.A.

Analog-for-the-Digital Age, Application Maestro, CodeGuard, dsPICDEM, dsPICDEM.net, dsPICworks, dsSPEAK, ECAN, ECONOMONITOR, FanSense, HI-TIDE, In-Circuit Serial Programming, ICSP, Mindi, MiWi, MPASM, MPLAB Certified logo, MPLIB, MPLINK, mTouch, Octopus, Omniscient Code Generation, PICC, PICC-18, PICDEM, PICDEM.net, PICkit, PICTail, REAL ICE, rLAB, Select Mode, Total Endurance, TSHARC, UniWinDriver, WiperLock and ZENA are trademarks of Microchip Technology Incorporated in the U.S.A. and other countries.

SQTP is a service mark of Microchip Technology Incorporated in the U.S.A.

All other trademarks mentioned herein are property of their respective companies.

© 2010, Microchip Technology Incorporated, Printed in the U.S.A., All Rights Reserved.

 Printed on recycled paper.

ISBN: 978-1-60932-126-0

*Microchip received ISO/TS-16949:2002 certification for its worldwide headquarters, design and wafer fabrication facilities in Chandler and Tempe, Arizona; Gresham, Oregon and design centers in California and India. The Company's quality system processes and procedures are for its PIC<sup>®</sup> MCUs and dsPIC<sup>®</sup> DSCs, KEELOQ<sup>®</sup> code hopping devices, Serial EEPROMs, microperipherals, nonvolatile memory and analog products. In addition, Microchip's quality system for the design and manufacture of development systems is ISO 9001:2000 certified.*

**QUALITY MANAGEMENT SYSTEM  
CERTIFIED BY DNV  
== ISO/TS 16949:2002 ==**



---

---

## WORLDWIDE SALES AND SERVICE

---

---

### AMERICAS

**Corporate Office**  
2355 West Chandler Blvd.  
Chandler, AZ 85224-6199  
Tel: 480-792-7200  
Fax: 480-792-7277  
Technical Support:  
<http://support.microchip.com>  
Web Address:  
[www.microchip.com](http://www.microchip.com)

**Atlanta**  
Duluth, GA  
Tel: 678-957-9614  
Fax: 678-957-1455

**Boston**  
Westborough, MA  
Tel: 774-760-0087  
Fax: 774-760-0088

**Chicago**  
Itasca, IL  
Tel: 630-285-0071  
Fax: 630-285-0075

**Cleveland**  
Independence, OH  
Tel: 216-447-0464  
Fax: 216-447-0643

**Dallas**  
Addison, TX  
Tel: 972-818-7423  
Fax: 972-818-2924

**Detroit**  
Farmington Hills, MI  
Tel: 248-538-2250  
Fax: 248-538-2260

**Kokomo**  
Kokomo, IN  
Tel: 765-864-8360  
Fax: 765-864-8387

**Los Angeles**  
Mission Viejo, CA  
Tel: 949-462-9523  
Fax: 949-462-9608

**Santa Clara**  
Santa Clara, CA  
Tel: 408-961-6444  
Fax: 408-961-6445

**Toronto**  
Mississauga, Ontario,  
Canada  
Tel: 905-673-0699  
Fax: 905-673-6509

### ASIA/PACIFIC

**Asia Pacific Office**  
Suites 3707-14, 37th Floor  
Tower 6, The Gateway  
Harbour City, Kowloon  
Hong Kong  
Tel: 852-2401-1200  
Fax: 852-2401-3431

**Australia - Sydney**  
Tel: 61-2-9868-6733  
Fax: 61-2-9868-6755

**China - Beijing**  
Tel: 86-10-8528-2100  
Fax: 86-10-8528-2104

**China - Chengdu**  
Tel: 86-28-8665-5511  
Fax: 86-28-8665-7889

**China - Chongqing**  
Tel: 86-23-8980-9588  
Fax: 86-23-8980-9500

**China - Hong Kong SAR**  
Tel: 852-2401-1200  
Fax: 852-2401-3431

**China - Nanjing**  
Tel: 86-25-8473-2460  
Fax: 86-25-8473-2470

**China - Qingdao**  
Tel: 86-532-8502-7355  
Fax: 86-532-8502-7205

**China - Shanghai**  
Tel: 86-21-5407-5533  
Fax: 86-21-5407-5066

**China - Shenyang**  
Tel: 86-24-2334-2829  
Fax: 86-24-2334-2393

**China - Shenzhen**  
Tel: 86-755-8203-2660  
Fax: 86-755-8203-1760

**China - Wuhan**  
Tel: 86-27-5980-5300  
Fax: 86-27-5980-5118

**China - Xian**  
Tel: 86-29-8833-7252  
Fax: 86-29-8833-7256

**China - Xiamen**  
Tel: 86-592-2388138  
Fax: 86-592-2388130

**China - Zhuhai**  
Tel: 86-756-3210040  
Fax: 86-756-3210049

### ASIA/PACIFIC

**India - Bangalore**  
Tel: 91-80-3090-4444  
Fax: 91-80-3090-4123

**India - New Delhi**  
Tel: 91-11-4160-8631  
Fax: 91-11-4160-8632

**India - Pune**  
Tel: 91-20-2566-1512  
Fax: 91-20-2566-1513

**Japan - Yokohama**  
Tel: 81-45-471- 6166  
Fax: 81-45-471-6122

**Korea - Daegu**  
Tel: 82-53-744-4301  
Fax: 82-53-744-4302

**Korea - Seoul**  
Tel: 82-2-554-7200  
Fax: 82-2-558-5932 or  
82-2-558-5934

**Malaysia - Kuala Lumpur**  
Tel: 60-3-6201-9857  
Fax: 60-3-6201-9859

**Malaysia - Penang**  
Tel: 60-4-227-8870  
Fax: 60-4-227-4068

**Philippines - Manila**  
Tel: 63-2-634-9065  
Fax: 63-2-634-9069

**Singapore**  
Tel: 65-6334-8870  
Fax: 65-6334-8850

**Taiwan - Hsin Chu**  
Tel: 886-3-6578-300  
Fax: 886-3-6578-370

**Taiwan - Kaohsiung**  
Tel: 886-7-536-4818  
Fax: 886-7-536-4803

**Taiwan - Taipei**  
Tel: 886-2-2500-6610  
Fax: 886-2-2508-0102

**Thailand - Bangkok**  
Tel: 66-2-694-1351  
Fax: 66-2-694-1350

### EUROPE

**Austria - Wels**  
Tel: 43-7242-2244-39  
Fax: 43-7242-2244-393

**Denmark - Copenhagen**  
Tel: 45-4450-2828  
Fax: 45-4485-2829

**France - Paris**  
Tel: 33-1-69-53-63-20  
Fax: 33-1-69-30-90-79

**Germany - Munich**  
Tel: 49-89-627-144-0  
Fax: 49-89-627-144-44

**Italy - Milan**  
Tel: 39-0331-742611  
Fax: 39-0331-466781

**Netherlands - Drunen**  
Tel: 31-416-690399  
Fax: 31-416-690340

**Spain - Madrid**  
Tel: 34-91-708-08-90  
Fax: 34-91-708-08-91

**UK - Wokingham**  
Tel: 44-118-921-5869  
Fax: 44-118-921-5820