



Chipsmall Limited consists of a professional team with an average of over 10 year of expertise in the distribution of electronic components. Based in Hongkong, we have already established firm and mutual-benefit business relationships with customers from,Europe,America and south Asia,supplying obsolete and hard-to-find components to meet their specific needs.

With the principle of “Quality Parts,Customers Priority,Honest Operation,and Considerate Service”,our business mainly focus on the distribution of electronic components. Line cards we deal with include Microchip,ALPS,ROHM,Xilinx,Pulse,ON,Everlight and Freescale. Main products comprise IC,Modules,Potentiometer,IC Socket,Relay,Connector.Our parts cover such applications as commercial,industrial, and automotives areas.

We are looking forward to setting up business relationship with you and hope to provide you with the best service and solution. Let us make a better world for our industry!



## Contact us

Tel: +86-755-8981 8866 Fax: +86-755-8427 6832

Email & Skype: info@chipsmall.com Web: www.chipsmall.com

Address: A1208, Overseas Decoration Building, #122 Zhenhua RD., Futian, Shenzhen, China



# Features

- Universal AC Input (85-264VAC)
- Long 7 Year Warranty
- Protections: SCP, OVP, OCP, OTP
- 100% Full Load burn-in test
- DC OK Indicator LED with Relay Contacts
- cooling by free air convection, 5000m operation
- UL, CSA & CE certified with CB Report

**RECOM**  
AC/DC Converter

## REDIN60

**60 Watt  
DIN-Rail  
Power  
Supply**



### Description

This DIN-rail mounted power supply uses high reliability components to give a long, trouble-free life. The power supply can be end mounted to save space or side mounted for use in low-profile cabinets. Relay contacts simplify DC OK monitoring and the units can deliver 80W start-up power. The REDIN series is fully certified for industrial use and carries a 7-year warranty.

### Selection Guide

Part Number	Input Voltage Range (VAC)	Output Voltage (VDC)	Output Trimming Voltage (VDC)	Rated Current (A)	Efficiency typ. (%)	Max. Capacitive Load (µF)
REDIN60-12	85-264	12	12-15	5.0	85	18800
REDIN60-24	85-264	24	24-28	2.5	86	4700



### Specifications (measured at TA= 25°C, 230VAC, full load and after warm up)

BASIC CHARACTERISTICS				
Parameter	Condition	Min.	Typ.	Max.
Input Voltage Range	all operating conditions	85VAC		264VAC
max. Input Voltage	max. 1 second			300VAC 375VDC
Output Voltage Adjustment (Factory Setting) <sup>(1)</sup>	12Vout 24Vout		12-15VDC (12V±5%) 24-28VDC (24V±5%)	
Input Current	full load, 115VAC full load, 230VAC			1.8A 1.0A
absolute max. Input Current	cold start at 25°C, 115VAC cold start at 25°C, 230VAC			40A 60A
No Load Power Consumption	standard (with Relay) /NR option (no Relay)			<1000mW <500mW
Start Up time	cold start, 230VAC		500ms	1000ms
Rise time	cold start, 230VAC		20ms	
Hold-up time	full load, 115VAC full load, 230VAC		20ms 50ms	
Input Frequency Range		47Hz		63Hz
Operating Frequency Range			65kHz	
Efficiency		see Selection Guide		
Output Ripple and Noise <sup>(2)</sup>	12Vout 24Vout		60mVp-p 75mVp-p	
Over Load	all operating conditions		140% for 5 seconds max.	

#### Notes:

Note1: For more details refer to Vadj. Derating Graph

Note2: Ripple and Noise are measured at 20MHz bandwidth by using a 12" twisted pair-wire terminated with 0.1µF & 47µF parallel capacitor.

continued on next page



#### CB-Report

UL-60950-1 Certified

UL-508 Certified

IEC-60950-1 Certified

EN-60715 Compliant

EN-50022 Compliant

CSA C22.2 No. 60950-1-07 Certified



Specifications (measured at  $T_A = 25^\circ\text{C}$ , 230VAC, full load and after warm up)

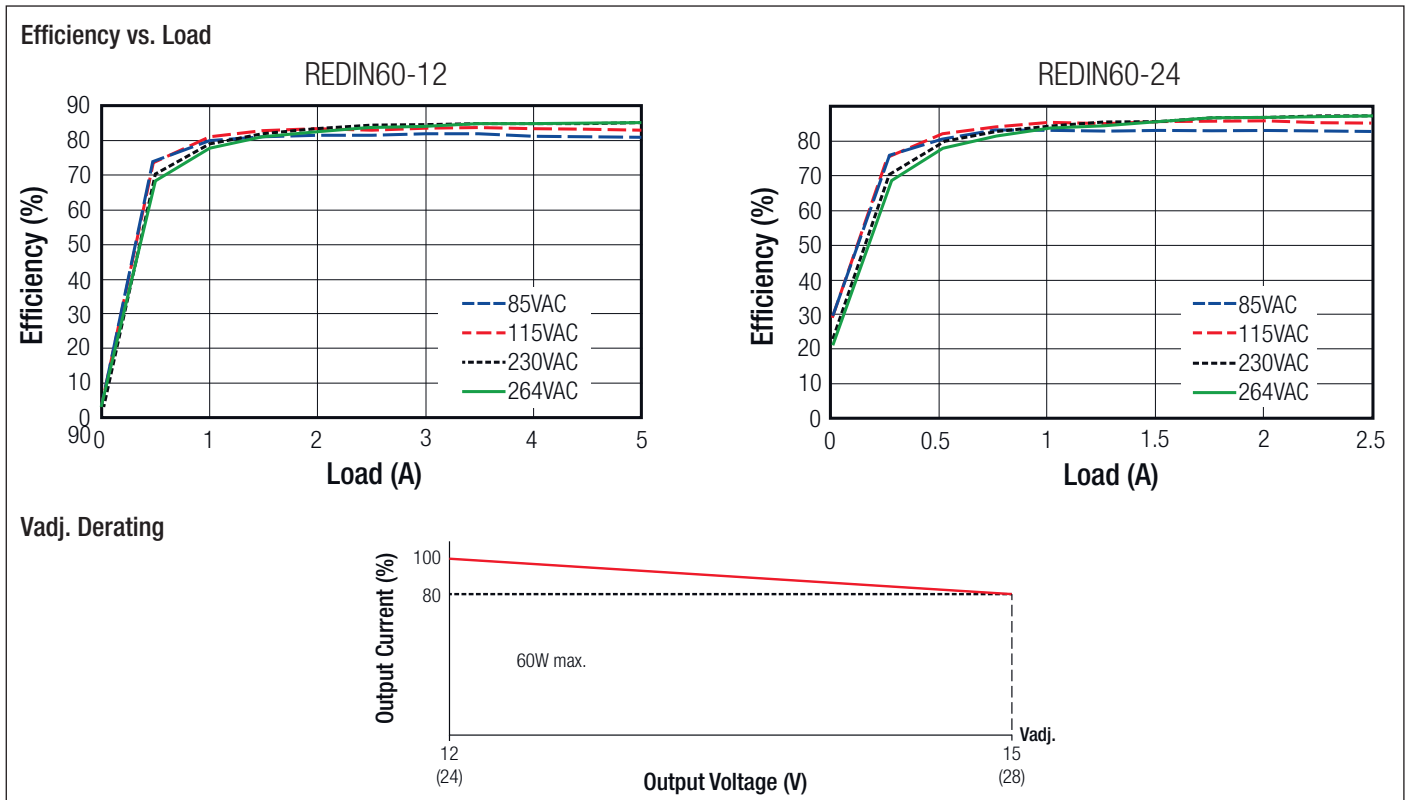

REGULATION		
Parameter	Condition	Value
Line Voltage Regulation		$\pm 0.1$ typ. / $\pm 1\%$ max.
Load Voltage Regulation		$\pm 0.1$ typ. / $\pm 1\%$ max.
Transient Response <sup>(3)</sup>	12Vout (step load change: 2.5A - 5.0A) 24Vout (step load change: 1.25A - 2.5A)	$\pm 5\%$ typ. $\pm 5\%$ typ.
Dwell Time		100Hz & 1kHz 50% duty
Slew Rate		0.5A / $\mu\text{s}$
<b>Notes:</b>		
Note3: Transient Response + E-CAP loading 3300 $\mu\text{F}$ . Other specs with resistive load only.		

PROTECTION		
Parameter	Condition	Value
Input Fuse		T2.5A, slow blow type
Short Circuit Protection (SCP)	Hiccup	auto-recovery after fault condition
Over Voltage Protection (OVP)	12Vout 24Vout	18VDC max., shut-down latch-off o/p voltage, re-power on to recover 35VDC max., shut-down latch-off o/p voltage, re-power on to recover
Over Current Protection (OCP)		150% typ., auto-recovery after fault condition
Over Temperature Protection (OTP)	detect on inside ambient	105°C $\pm 5\%$ , shut-down latch-off o/p voltage, re-power on to recover
Isolation Voltage	I/P to O/P	3.75kVAC / 1 minute
	I/P to FG	1.88kVAC / 1 minute
	O/P to FG	0.5kVAC / 1 minute
Isolation Resistance	500VDC, 70% RH, I/P to O/P; I/P to FG; O/P to FG	100M $\Omega$ min.
Leakage Current	240VAC	>1mA
Power OK LED	Relay Contacts	1A, 30VDC / 120VAC
	LED/Relay	ON if Vout = 11-16V (12V) / 22-30V (24V)

Specifications (measured at  $T_A= 25^\circ\text{C}$ , 230VAC, full load and after warm up)

**ENVIRONMENTAL**

Parameter	Condition	Value
Operating Temperature Range	with derating	-20°C to +70°C (see graph)
Operating Humidity	non-condensing	20% - 90%RH
Vibration		10-500Hz 2G, 60min.
Shock	3 times each axis	10G / 11ms, along X, Y and Z axis
Altitude	see derating graph	5000m
MTBF (+25°C)	MIL-HDBK-217F, 115VAC, 60Hz, 75% load	200 x 10 <sup>3</sup> hours
Design Lifetime (+40°C)		87.6 x 10 <sup>3</sup> hours

**Derating Graph**

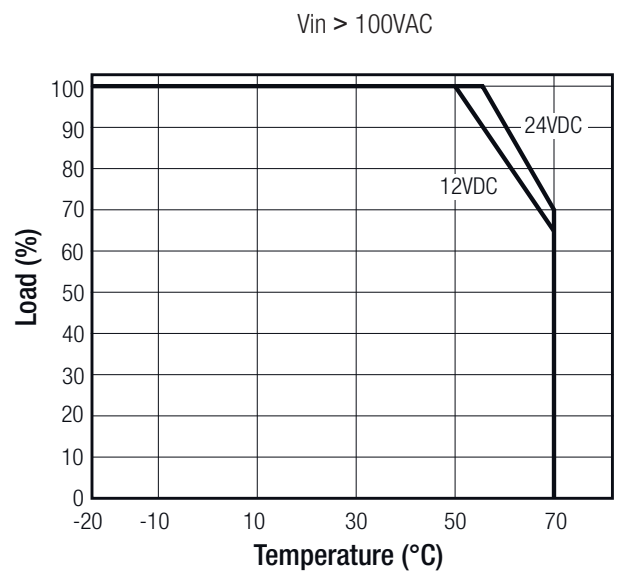
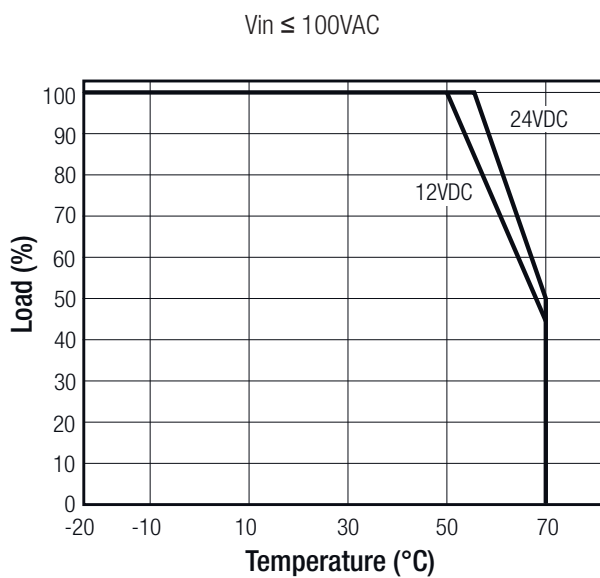

**Typical Characteristics**

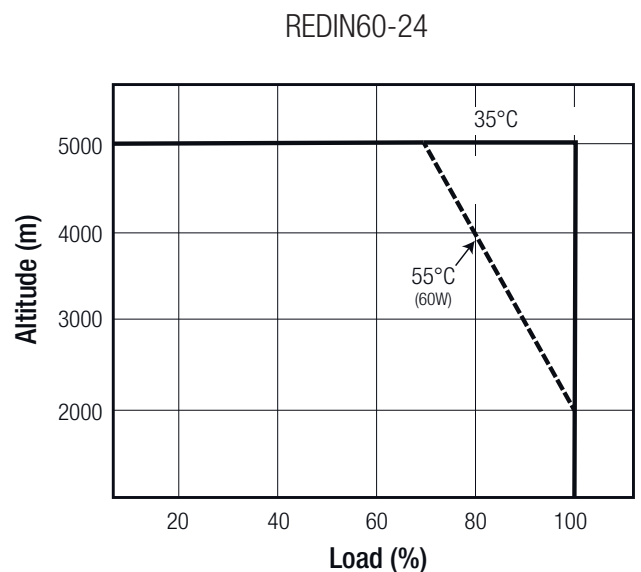
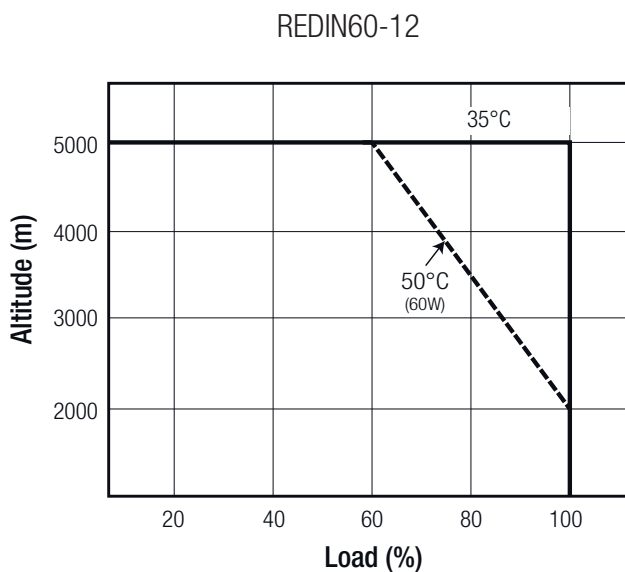

Specifications (measured at  $T_A = 25^\circ\text{C}$ , 230VAC, full load and after warm up)

SAFETY AND CERTIFICATIONS		
Certificate Type (Safety)	Report / File Number	Standard
UL General Safety	E224736	UL60950-1, 2nd Edition
CSA General Safety		UL-1310 C22.2 No. 60950-1-07, 2nd Edition
Industrial Control Equipment General Use Power Supplies	E470721	UL508 C22.2 No. 107.1
IEC/EN General Safety	E224736	IEC/EN-60950-1, 2nd Edition
Chinese Safety Standard	E224736	GB 4943.1-2011
EMC Compliance		
EMC Compliance	Report / Condition	Standard / Criterion
EMI Standard	Report: HA150146	EN55022, Class B
		EN55024, Class B
		FCC15, Class B
ESD	$\pm 8\text{kV}$ Contact & Air Discharge	EN61000-4-2, Criteria A
Radiated Immunity	10V/m, 80-3000MHz, 80% AM at 1kHz	EN61000-4-3, Criteria A
Fast Transient	Level 2	EN61000-4-4, Criteria A
Surge	$\pm 2\text{kV}$ / L-N, $\pm 4\text{kV}$ / L, N-FG	EN61000-4-5, Criteria A
Conducted Immunity	10Vrms, 0.15-80MHz, 80% AM at 1kHz	EN61000-4-6, Criteria A
Power frequency magnetic field immunity test		EN61000-4-8, Criteria A
Noise Immunity	40% reduction, 200ms	EN61000-4-11, Criteria A
	70% reduction, 500ms	EN61000-4-11, Criteria B
	90% reduction, 5s	EN61000-4-11, Criteria B
Harmonic Immunity	not applicable input below 75W	EN61000-3-2
Voltage Flicker		EN61000-3-3

### DIMENSION and PHYSICAL CHARACTERISTICS

Parameter	Type	Value
Case Material		UL94V-0 plastic
Package Dimension (WxHxD)		45.1 x 92.0 x 101.2mm
Package Weight		332g

#### Dimension Drawing (mm)

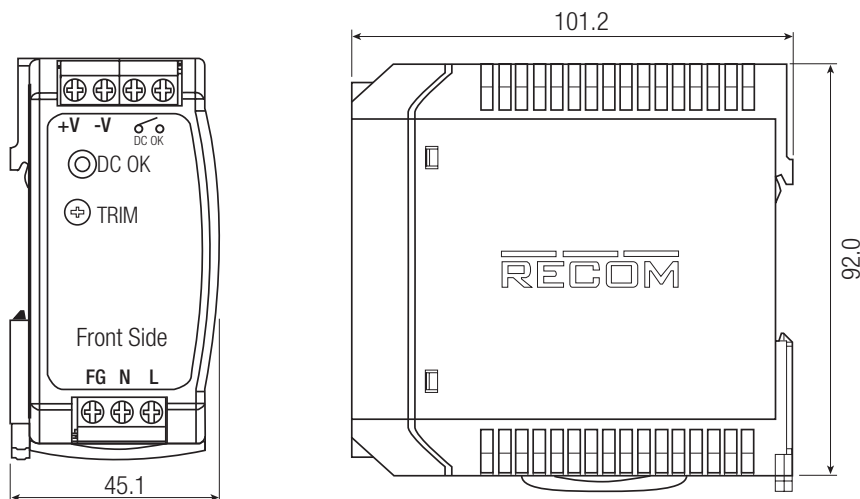

continued on next page

Specifications (measured at  $T_A = 25^\circ\text{C}$ , 230VAC, full load and after warm up)

Dimension Drawing (mm)

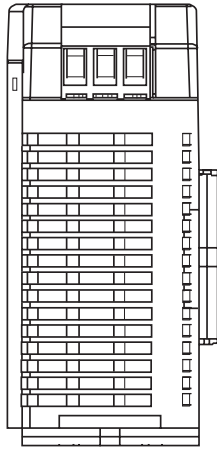

DIN-RAIL mounting bracket  
(75mm) included

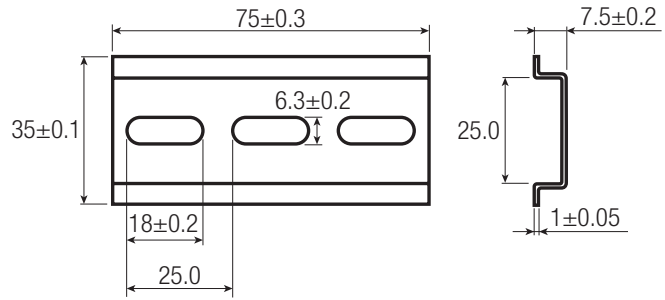

INSTALLATION

END MOUNTING

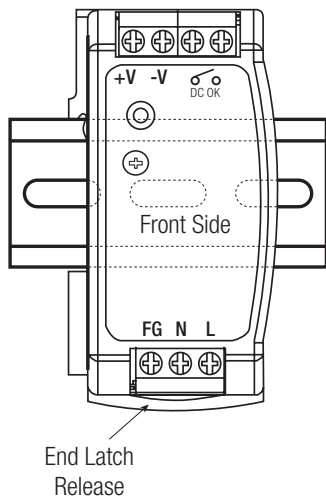

SIDE MOUNTING

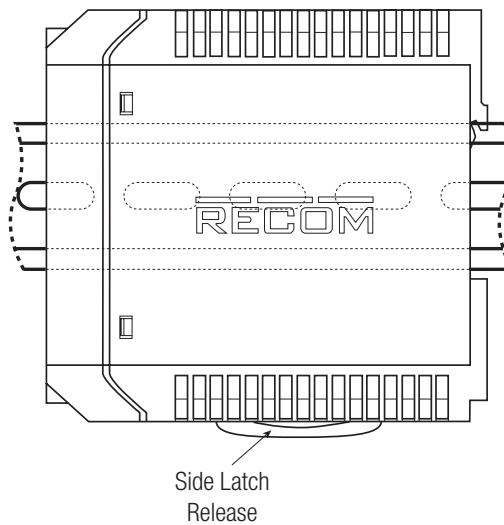

Mounting Instruction

Mounting

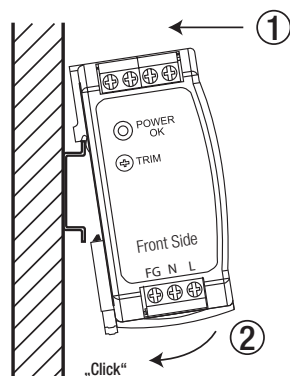

Releasing

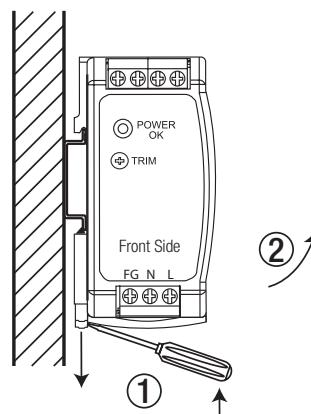

continued on next page

Specifications (measured at  $T_A = 25^\circ\text{C}$ , 230VAC, full load and after warm up)

### Mounting Multiple Power Supplies

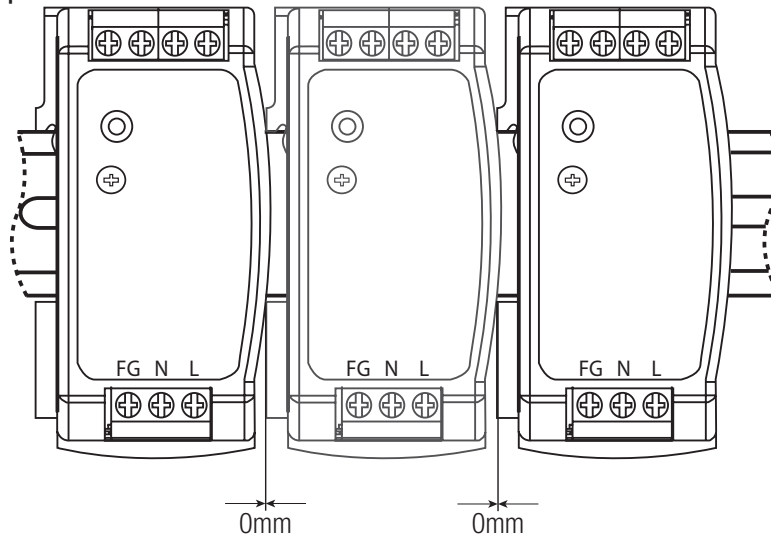

no spacers between  
supplies required

### Functional Diagram

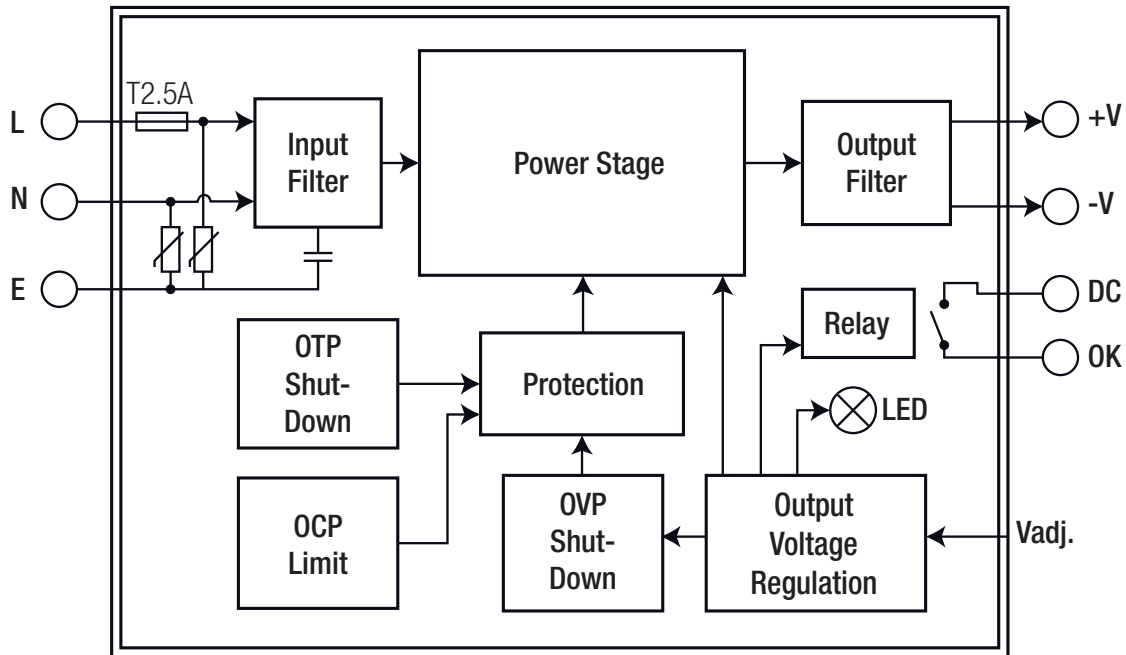

### PACKAGING INFORMATION

Parameter	Type	Value
Packaging Dimension (LxWxH)	Cardboard Box	116.0 x 97.0 x 54mm
Packaging Quantity		1pcs
Storage Temperature Range		-30°C to +85°C
Storage Humidity		10% - 90% RH

The product information and specifications are subject to change without prior notice. RECOM products are not authorized for use in safety-critical applications (such as life support) without RECOM's explicit written consent. A safety-critical application is defined as an application where a failure of a RECOM product may reasonably be expected to endanger or cause loss of life, inflict bodily harm or damage property. The buyer shall indemnify and hold harmless RECOM, its affiliated companies and its representatives against any damage claims in connection with the unauthorized use of RECOM products in such safety-critical applications.