



Chipsmall Limited consists of a professional team with an average of over 10 year of expertise in the distribution of electronic components. Based in Hongkong, we have already established firm and mutual-benefit business relationships with customers from,Europe,America and south Asia,supplying obsolete and hard-to-find components to meet their specific needs.

With the principle of “Quality Parts,Customers Priority,Honest Operation,and Considerate Service”,our business mainly focus on the distribution of electronic components. Line cards we deal with include Microchip,ALPS,ROHM,Xilinx,Pulse,ON,Everlight and Freescale. Main products comprise IC,Modules,Potentiometer,IC Socket,Relay,Connector.Our parts cover such applications as commercial,industrial, and automotives areas.

We are looking forward to setting up business relationship with you and hope to provide you with the best service and solution. Let us make a better world for our industry!



Contact us

Tel: +86-755-8981 8866 Fax: +86-755-8427 6832

Email & Skype: info@chipsmall.com Web: www.chipsmall.com

Address: A1208, Overseas Decoration Building, #122 Zhenhua RD., Futian, Shenzhen, China





Features

- Low Noise and High Intercept Point
- Adjustable Bias Current
- Power Down Control
- Low Insertion Loss Bypass Feature
- 1.8V to 4V Operation (See Note: Page 2)
- 800MHz to 3.8GHz Operation
- ESD Class 1B

Applications

- WiFi LNA with Bypass Feature
- CDMA PCS LNA with Bypass Feature
- GPS LNA with Bypass Feature
- General Purpose Amplification
- WiMAX LNA with Bypass Function
- CDMA 800 LNA
- CMMB LNA
- LTE Bands LNA

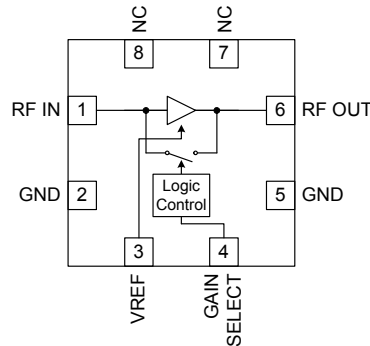

Functional Block Diagram

Product Description

The RF2374 is a switchable low noise amplifier with a high dynamic range designed for digital cellular and WiFi applications. The device functions as an outstanding front end low noise amplifier with I_{CC} as low as 3mA. The bias current may be set externally. The IC is featured in a 2.2mmx2.2mmx0.6mm module-compatible plastic package.

Absolute Maximum Ratings

Parameter	Rating	Unit
Supply Voltage	-0.5 to +6.0	V _{DC}
Input RF Level at F < 2.3GHz	+5 (see note)	dBm
Input RF Level at F > 2.3GHz	+10 (see note)	dBm
Current Drain, I _{CC}	32	mA
Operating Ambient Temperature	-40 to +85	°C
Storage Temperature	-40 to +150	°C

NOTE: Exceeding any one or a combination of the above maximum rating limits may cause permanent damage. Input RF transients to +15dBm will not harm the device. For sustained operation at inputs $\geq +5$ dBm, a small dropping resistor is recommended in series with the V_{CC} in order to limit the current due to self-biasing to <32mA. Furthermore, while the LNA is in Bypass Mode, and for sustained operation at the input, +10dBm is the maximum recommended power level for Frequencies above 2300MHz. +5dBm is the maximum recommended power level for Frequencies <2300MHz.



Caution ESD sensitive device.

Exceeding any one or a combination of the Absolute Maximum Rating conditions may cause permanent damage to the device. Extended application of Absolute Maximum Rating conditions to the device may reduce device reliability. Specified typical performance or functional operation of the device under Absolute Maximum Rating conditions is not implied.

RoHS status based on EU Directive 2011/65/EU (at time of this document revision).

The information in this publication is believed to be accurate and reliable. However, no responsibility is assumed by RF Micro Devices, Inc. ("RFMD") for its use, nor for any infringement of patents, or other rights of third parties, resulting from its use. No license is granted by implication or otherwise under any patent or patent rights of RFMD. RFMD reserves the right to change component circuitry, recommended application circuitry and specifications at any time without prior notice.

Parameter	Specification			Unit	Condition
	Min.	Typ.	Max.		
Operating Range					T _{AMB} = +25 °C, V _{CC} = 3.0V
Frequency Range	50		4000	MHz	
WiBRO/WiFi/WiMAX Low Noise Amplifier					
Frequency	2300		2700	MHz	
HIGH GAIN MODE					Gain Select < 0.8V, V _{REF} = 3V, T = +25 °C
Gain	12.5	14.5	16.0	dB	
Noise Figure		1.3	1.5	dB	
Input IP3	+7	+9		dBm	IP3 will improve if I _{CC} is raised above 7 mA.
IP1dB	0			dBm	
Current Drain		7		mA	
BYPASS MODE (Low Gain)					Gain Select ≥ 1.6 V
Gain	-4.0	-3.0	-2.0	dB	Note: Bypass mode insertion loss will degrade gradually as V _{CC} goes below 2.7V.
Input IP3	+20	+21		dBm	
Current Drain		2.8	3.0	mA	Current drain includes I _{CC} + I _{REF}
GPS Low Noise Amplifier					
Frequency		1575		MHz	
Gain		17.5		dB	I _{CC} = 6.5 mA, I _{CC} + I _{REF} = 7.5 mA
Noise Figure		1.2		dB	
Input IP3		+7.0		dBm	
WiMAX Low Noise Amplifier					
Frequency	3100	3500	3800	MHz	I _{CC} = 7 mA
Gain	9.0	11.0	13.0	dB	
Noise Figure		1.6	2.5	dB	
Input IP3	+9.0	+10.0		dBm	IP3 will improve if I _{CC} is raised above 7 mA.
BYPASS MODE (Low Gain)					
Gain	-4.0	-3.0	-2.5	dB	
Input IP3	20.5	22.0		dBm	

Parameter	Specification			Unit	Condition
	Min.	Typ.	Max.		
CDMA Low Noise Amplifier					
HIGH GAIN MODE					
Frequency	869		894	MHz	
Gain		19		dB	
Noise Figure		1.0		dB	
Input IP3		+2.0		dBm	IIP3 will improve if I _{CC} is raised above 7 mA.
Current Drain		7		mA	
Low Band LNA					
HIGH GAIN MODE					
Frequency	50		950	MHz	
Gain		20		dB	88MHz
Gain		19		dB	870MHz
Noise Figure		2.5		dB	88MHz
Noise Figure		1.5		dB	870MHz
Input IP3		+2.0		dBm	IIP3 will improve if I _{CC} is raised above 7 mA.
PCS and LTE Band LNA					
Frequency	1750		2050	MHz	V _{CC} =2.2V, 25 °C
HIGH GAIN MODE					
Gain	15	16		dB	Gain Select < 0.8V
Noise Figure		1.1	1.3	dB	
Input IP3	8	9	10	dBm	IIP3 will improve if I _{CC} is raised above 7 mA
Current Drain		7		mA	
BYPASS MODE (Low Gain)					
Gain	-3	-2		dB	Gain Select > 1.6V
Input IP3	17	18		dBm	
Noise Figure		2.7	3.5	dB	
LTE Low Band LNA					
Frequency	704		950	MHz	V _{CC} =2.2V, 25 °C
HIGH GAIN MODE					
Gain	17	18		dB	Gain Select < 0.8V
Noise Figure		1.4	1.6	dB	
Input IP3	-3	0		dBm	IIP3 will improve if I _{CC} is raised above 7 mA
Current Drain		7		mA	
BYPASS MODE (Low Gain)					
Gain	-5	-4		dB	
Input IP3	14	15		dBm	
Noise Figure		5	6.6	dB	

Parameter	Specification			Unit	Condition
	Min.	Typ.	Max.		
Power Supply					
Voltage (V_{CC})		3		V	
Gain Select Low Level (High Gain Mode)			0.8	V	High Gain mode. Gain Select < 0.8V, V_{REF} = 3V (typical)
Gain Select High Level (Bypass Mode)	1.6			V	Low Gain mode. Gain Select \geq 1.6V, V_{REF} : see bias note 2
Gain Select On/Off Time			<150	nSec	(C1 values range from 3 to 10pF), Temp = -40 °C to +85 °C, and over process
Power Down	0		5	μ A	Gain Select < 0.8V, V_{REF} = 0V, V_{CC} = 3.0V

Bias note: Due to the presence of ESD protection circuitry on the RF2374, the maximum allowable collector bias voltage (pin 6) is 4.0V. Higher supply voltages such as 5V are permissible if a series resistor is used to drop V_{CC} to \leq 4.0V for a given I_{CC} .

Bias note 2: In bypass mode, V_{REF} is essentially a "don't care" condition. Pulling V_{REF} low when in bypass mode does conserve the small 1mA to 2mA supplied by V_{REF} .

Pin	Function	Description	Interface Schematic
1	RF IN	RF input pin. This part is designed such that 50Ω is the optimal source impedance for best noise figure. Best noise figure is achieved with only a series capacitor on the input.	
2	GND1	Ground connection. For best performance, keep traces physically short and connect immediately to ground plane.	
3	VREF	For low noise amplifier applications, this pin is used to control the bias current. An external resistor can be used to set the bias current for any V_{BIAS} voltage. This device will have good gain and noise figure with I_{CC} as low as 3mA.	
4	GAIN SELECT	This pin selects high gain and bypass modes. Gain Select $\leq 0.8V$, high gain. Gain Select $\geq 1.6V$, low gain.	
5	GND2	See GND1.	
6	RF OUT	Amplifier output pin. This pin is an open-collector output. It must be biased to V_{CC} through a choke or matching inductor.	
7	NC	Not connected.	
8	NC	Not connected.	
Pkg Gnd	GND	This pad should be connected to the ground plane by vias directly under the device.	

Package Drawing

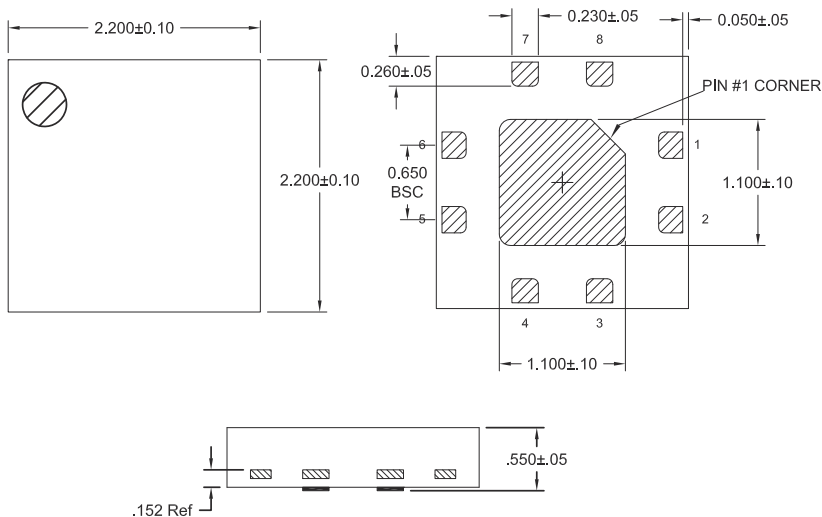

Evaluation Board Schematic WiFi (2.4GHz to 2.5GHz)

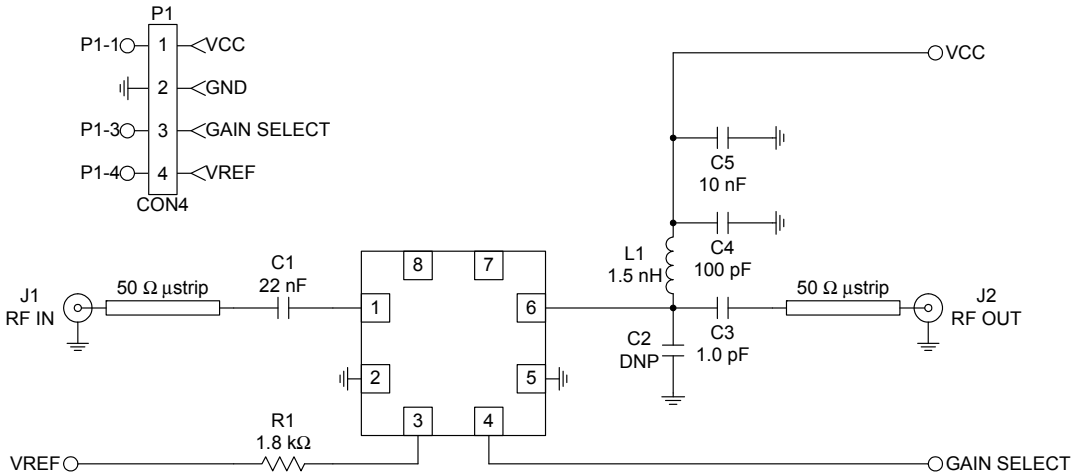

Evaluation Board Schematic GPS/PCS (1.5GHz to 2.2GHz)

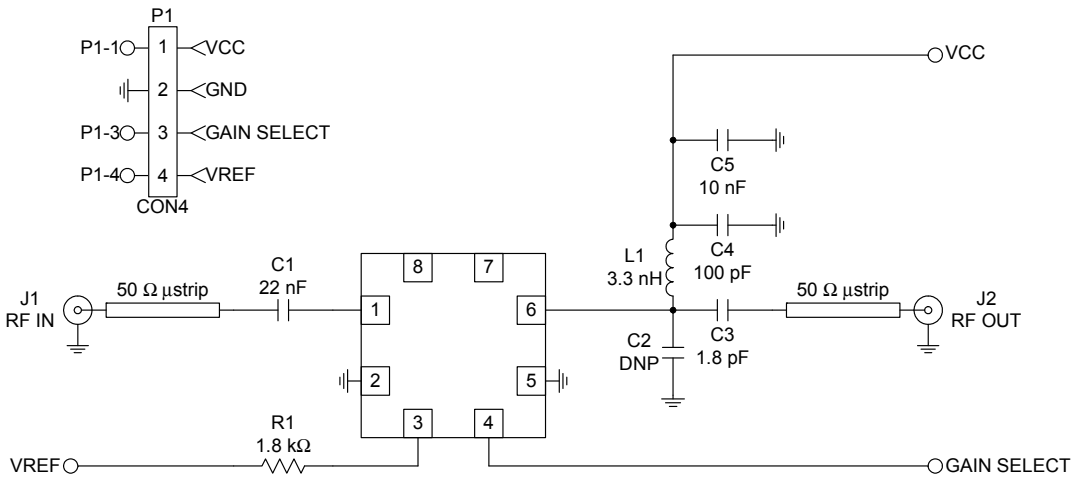

Application Schematic - 869MHz to 894MHz Tune

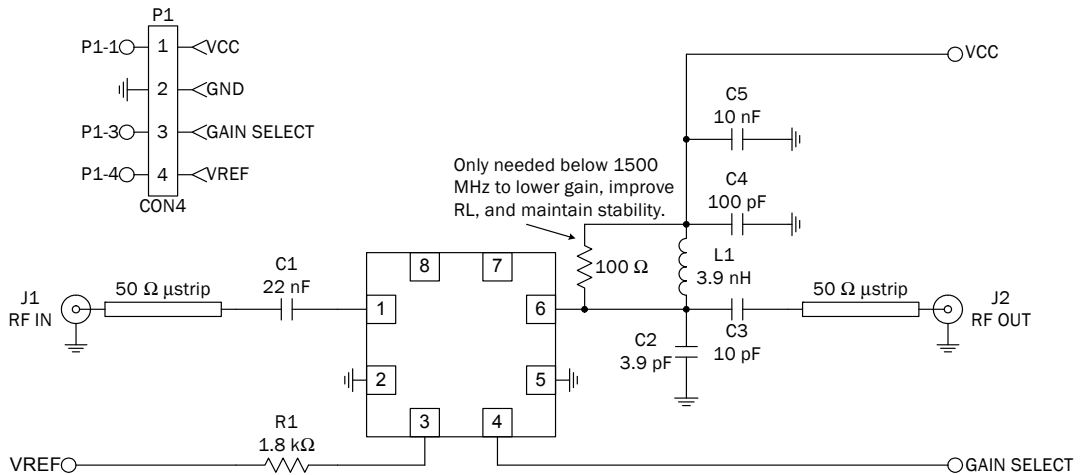

Application Schematic for Wide Band Tune WiBRO/WiFi/WiMAX (2.3GHz to 3.8GHz)

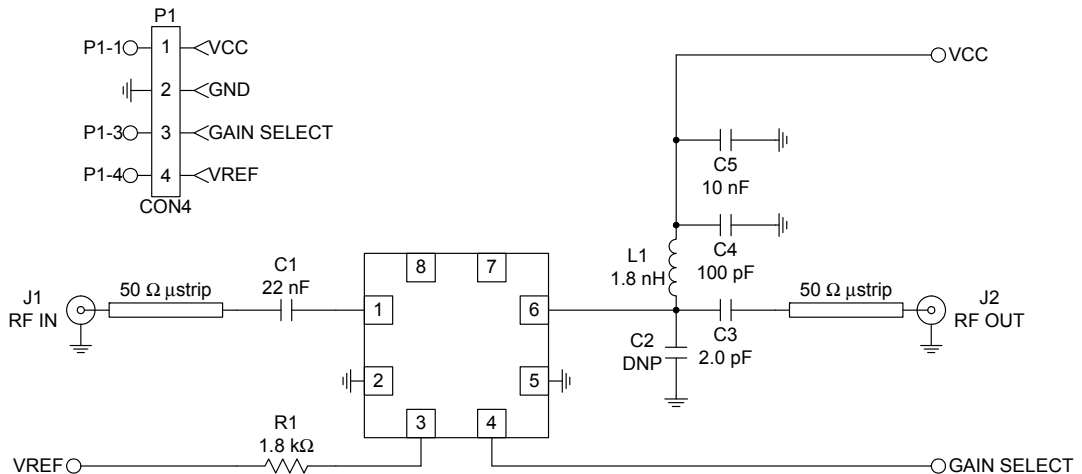

Application Schematic for Low Band Tune

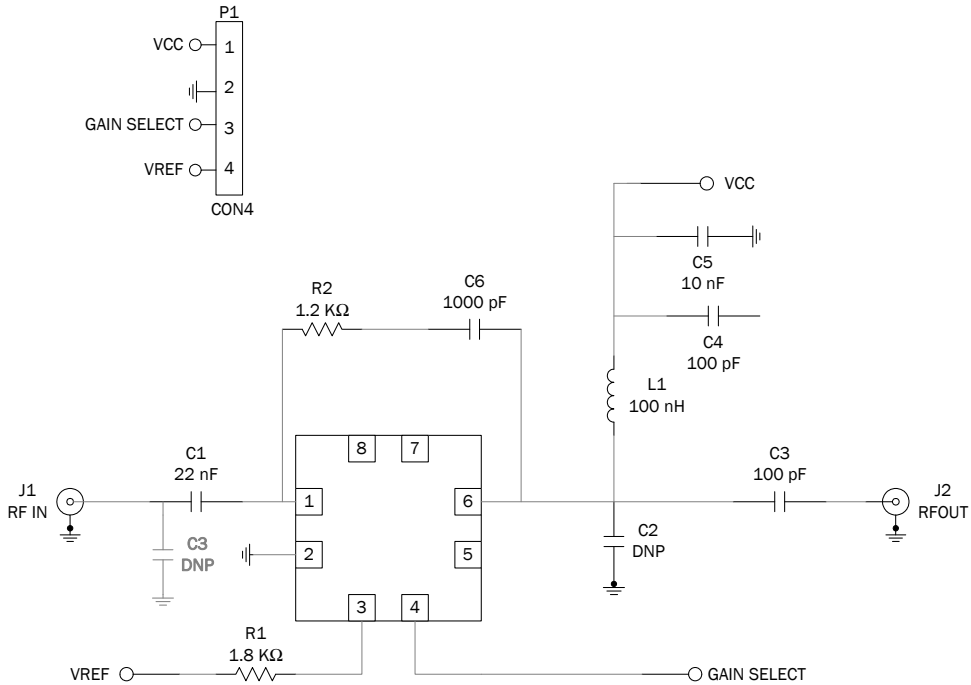

Evaluation Board Layout Board Size 0.835" x 0.900"

Board Thickness 0.032", Board Material FR-4

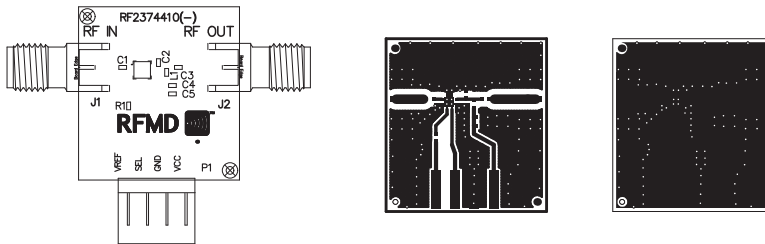

GPS Band Data

Gain @ GPS Band in High Gain Mode
 $V_{CC}=3.0V$ and $V_{REF}=3.0V$ Over Temp

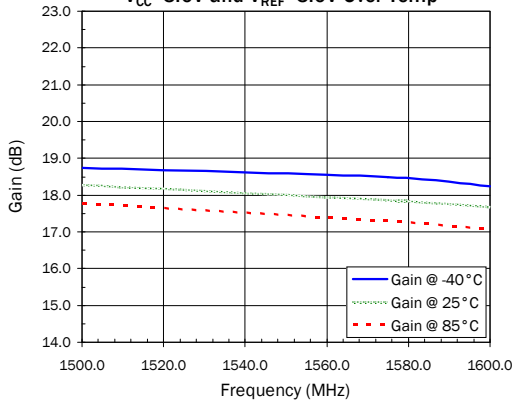

Gain @ GPS Band in Bypass Mode
 $V_{CC}=3.0V$ and $V_{REF}=3.0V$ Over Temp

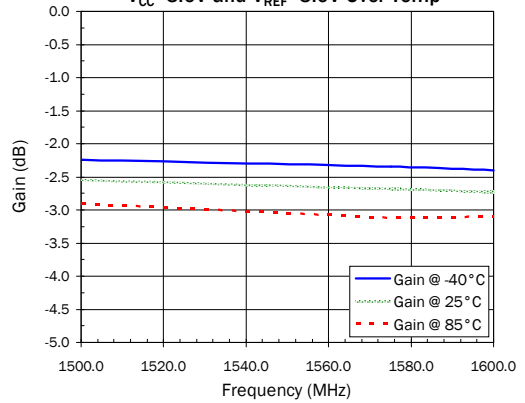

Noise Figure @ GPS Band in High Gain Mode
 $V_{CC}=3.0V$ and $V_{REF}=3.0V$ Over Temp

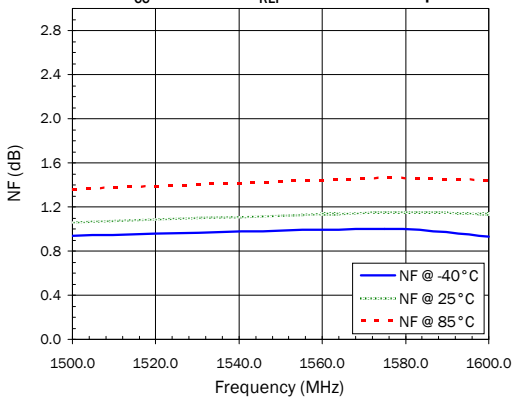

Noise Figure @ GPS Band in Bypass Mode
 $V_{CC}=3.0V$ and $V_{REF}=3.0V$ Over Temp

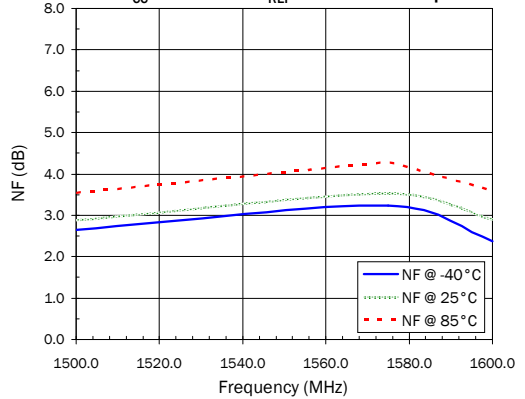

IIP3 @ GPS Band in High Gain Mode
 $V_{CC}=3.0V$ and $V_{REF}=3.0V$ Over Temp

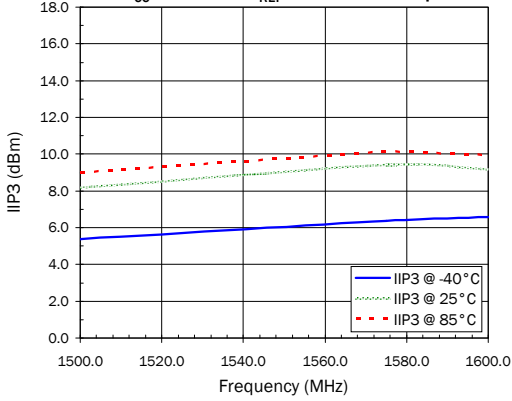

IIP3 @ GPS Band in Bypass Mode
 $V_{CC}=3.0V$ and $V_{REF} = 3.0V$ Over Temp

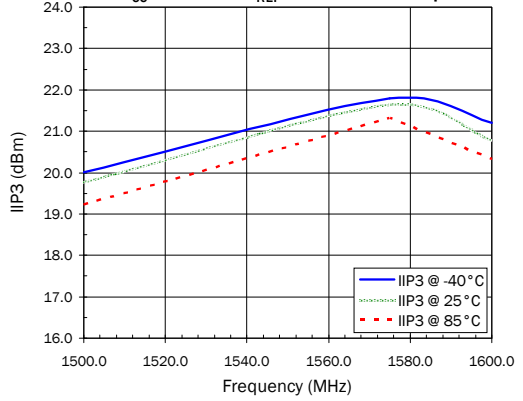

IIP3 @ GPS Band in Bypass Mode
 $V_{CC}=3.0V$ and $V_{REF} = 3.0V$ Over Temp

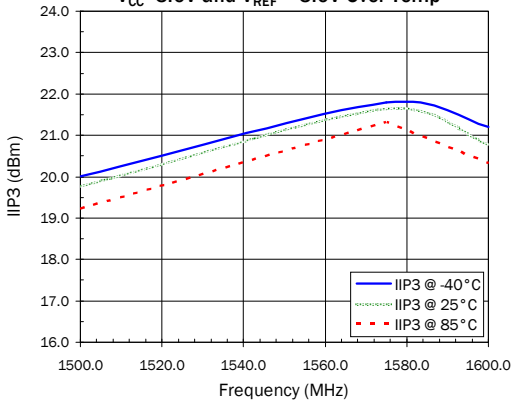

WiBRO/WiFi/WiMAX Data

Gain at WiFi Band in High Gain Mode
 $V_{CC}=3.0V$ and $V_{REF}=3.0V$ Over Temp

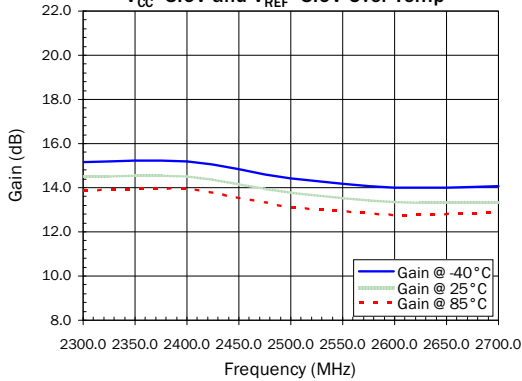

Gain at WiFi Band in Bypass Mode
 $V_{CC}=3.0V$ and $V_{REF}=3.0V$ Over Temp

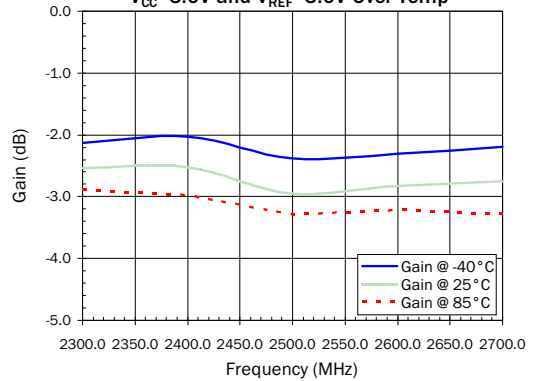

Noise Figure at WiFi Band in High Gain Mode
 $V_{CC}=3.0V$ and $V_{REF}=3.0V$ Over Temp

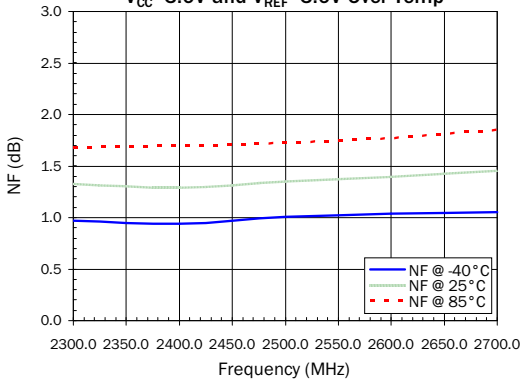

IIP3 at WiFi Band in High Gain Mode
 $V_{CC}=3.0V$ and $V_{REF}=3.0V$ Over Temp

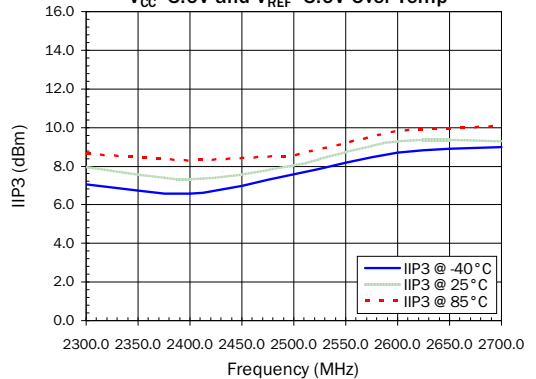

IIP3 at WiFi Band in Bypass Mode
 $V_{CC}=3.0V$ and $V_{REF}=3.0V$ Over Temp

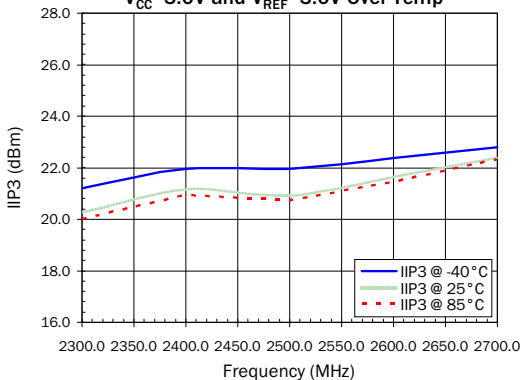

$I_{CC} + I_{REF}$ at WiFi Band in High Gain Mode
 $V_{CC}=3.0V$ and $V_{REF}=3.0V$ Over Temp

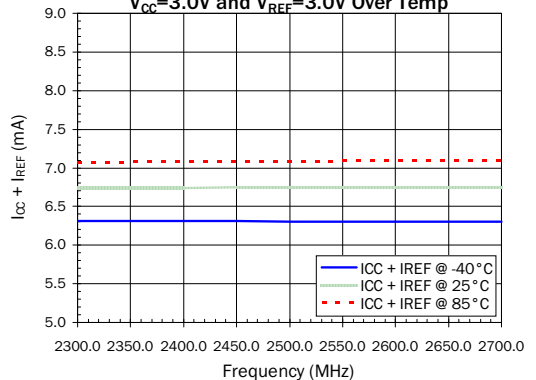

WiMAX Data

Gain @ WiMAX Band in High Gain Mode
 $V_{CC}=3.0V$ and $V_{REF}=3.0V$ Over Temp

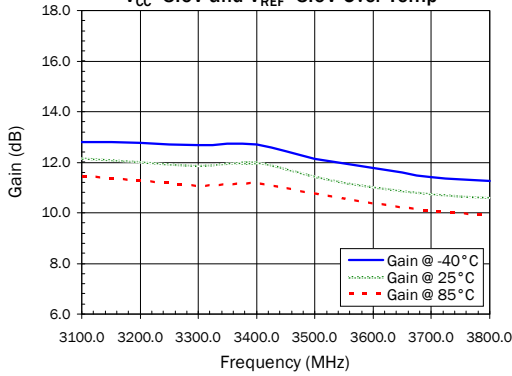

Gain @ WiMAX Band in Bypass Mode
 $V_{CC}=3.0V$ and $V_{REF}=3.0V$ Over Temp

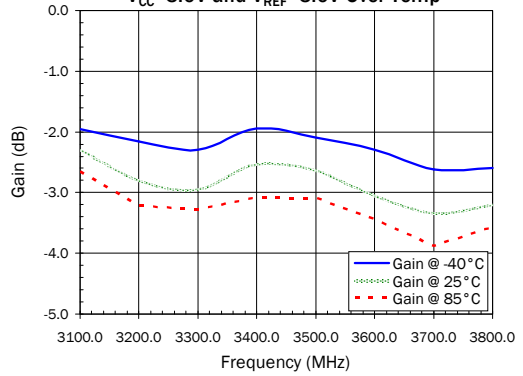

Noise Figure @ WiMAX Band in High Gain Mode
 $V_{CC}=3.0V$ and $V_{REF}=3.0V$ Over Temp

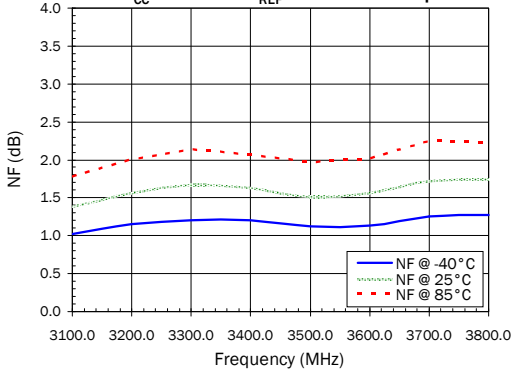

IIP3 @ WiMAX Band in High Gain Mode
 $V_{CC}=3.0V$ and $V_{REF}=3.0V$ Over Temp

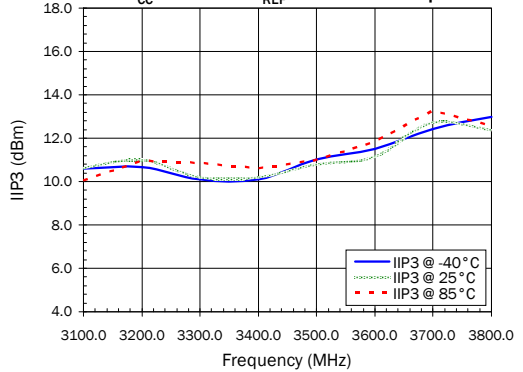

IIP3 @ WiMAX Band in Bypass Mode
 $V_{CC}=3.0V$ and $V_{REF}=3.0V$ Over Temp

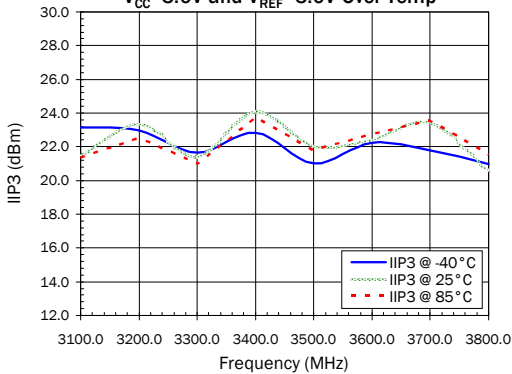

$I_{CC} + I_{REF}$ @ WiMAX Band in High Gain Mode
 $V_{CC}=3.0V$ and $V_{REF}=3.0V$ Over Temp

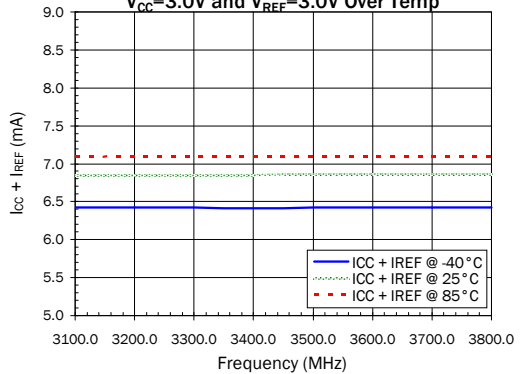

CDMA Data

Noise Figure Over Frequency and Voltage
($V_{CC}=3V$ to $5V$; $V_{REF}=3V$ to $3.6V$)

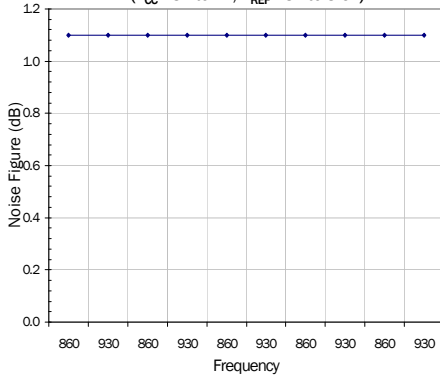

Gain

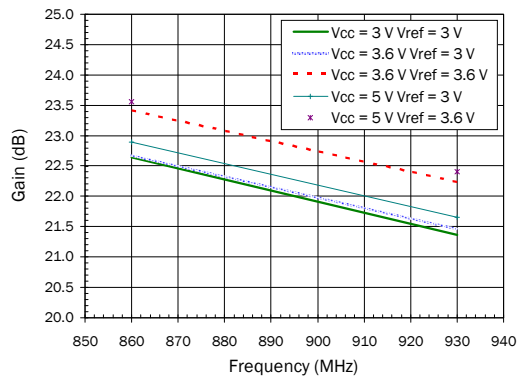

OIP3

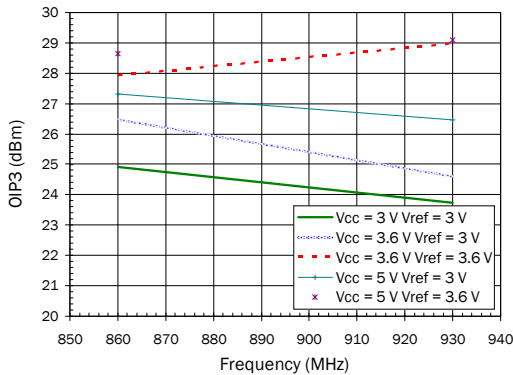

IIP3

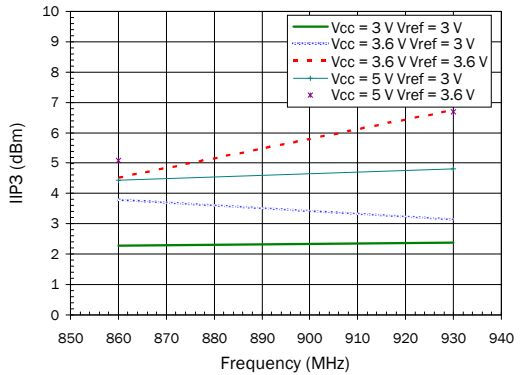

OP1dB

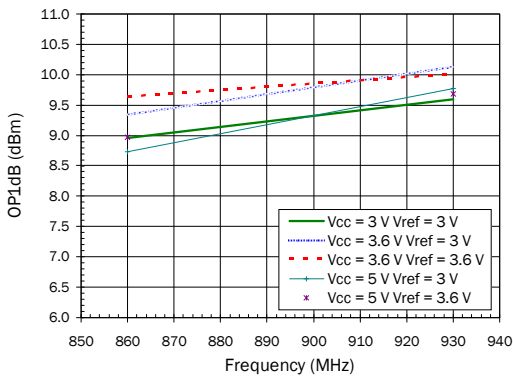

IP1dB

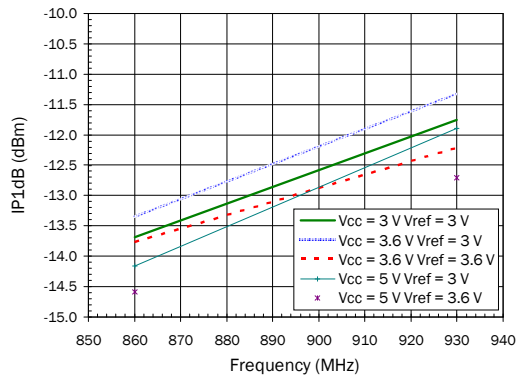

Low Band Tune Data

[S] Parameters Over Frequency
(V_{cc} = V_{ref} = 3.6V; V_{SEL} = 0V; I_{cc} = 8mA)

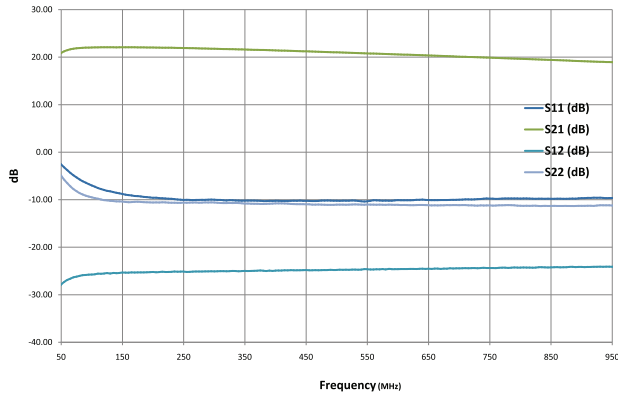

NF
(V_{cc} = V_{ref} = 3.6V ; V_{SEL} = 0V)

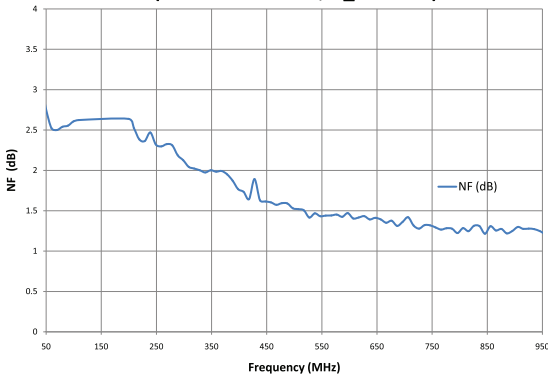

OP1dB, IIP3 and OIP3 over frequency
(V_{cc} = B_{ref} = 3.3V; I_{cc} = 8mA)

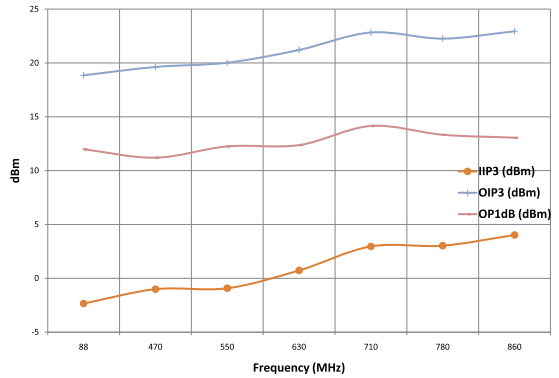

Ordering Information

Ordering Code	Description
RF2374	Standard 25 piece bag
RF2374SR	Standard 100 piece reel
RF2374TR7	Standard 2500 piece reel
RF2374PCK-410	Fully assembled evaluation board tuned for 2.4 GHz to 2.5GHz with standard tune
RF2374PCK-411	Fully assembled evaluation board tuned for 1.5 GHz to 2.2GHz with standard tune