



Chipsmall Limited consists of a professional team with an average of over 10 year of expertise in the distribution of electronic components. Based in Hongkong, we have already established firm and mutual-benefit business relationships with customers from,Europe,America and south Asia,supplying obsolete and hard-to-find components to meet their specific needs.

With the principle of “Quality Parts,Customers Priority,Honest Operation,and Considerate Service”,our business mainly focus on the distribution of electronic components. Line cards we deal with include Microchip,ALPS,ROHM,Xilinx,Pulse,ON,Everlight and Freescale. Main products comprise IC,Modules,Potentiometer,IC Socket,Relay,Connector.Our parts cover such applications as commercial,industrial, and automotives areas.

We are looking forward to setting up business relationship with you and hope to provide you with the best service and solution. Let us make a better world for our industry!



Contact us

Tel: +86-755-8981 8866 Fax: +86-755-8427 6832

Email & Skype: info@chipsmall.com Web: www.chipsmall.com

Address: A1208, Overseas Decoration Building, #122 Zhenhua RD., Futian, Shenzhen, China



RoHS Compliant & Pb-Free Product
Package Style: SOIC-16

Features

- Single 5V Power Supply
- Integrated RF Quadrature Network
- No Tuning Required
- Low LO Input Level
- Digitally Controlled Power Down Mode
- 800MHz to 2500MHz Operation

Applications

- Digital Communications Systems
- Spread-Spectrum Communication Systems
- GMSK, QPSK, DQPSK, QAM Modulation
- GSM, DCS 1800, JDC, D-AMPS Systems
- Commercial and Consumer Systems

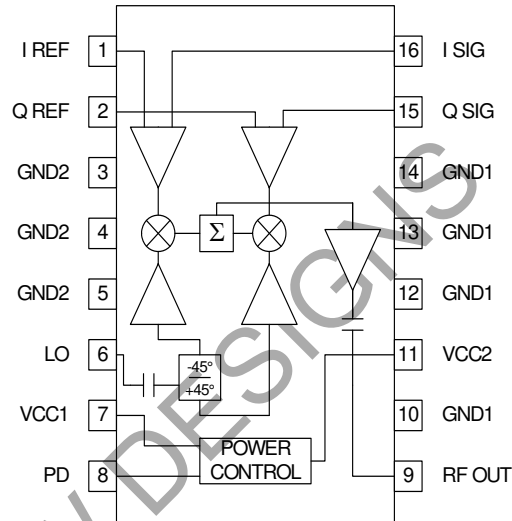

Functional Block Diagram

Product Description

The RF2422 is a monolithic integrated quadrature modulator IC capable of universal direct modulation for high-frequency AM, PM, or compound carriers. This low-cost IC implements differential amplifiers for the modulation inputs, 90° carrier phase shift network, carrier limiting amplifiers, two matched double-balanced mixers, summing amplifier, and an output RF amplifier which will drive 50Ω from 800MHz to 2500MHz. Component matching, which can only be accomplished with monolithic construction, is used to full advantage to obtain excellent amplitude balance and phase accuracy.

Ordering Information

RF2422 2.5GHz Direct Quadrature Modulator
RF2422PCBA-41X Fully Assembled Evaluation Board

Optimum Technology Matching® Applied

- | | | | |
|--|--------------------------------------|-------------------------------------|-----------------------------------|
| <input checked="" type="checkbox"/> GaAs HBT | <input type="checkbox"/> SiGe BiCMOS | <input type="checkbox"/> GaAs pHEMT | <input type="checkbox"/> GaN HEMT |
| <input type="checkbox"/> GaAs MESFET | <input type="checkbox"/> Si BiCMOS | <input type="checkbox"/> Si CMOS | |
| <input type="checkbox"/> InGaP HBT | <input type="checkbox"/> SiGe HBT | <input type="checkbox"/> Si BJT | |

RF MICRO DEVICES®, RFMD®, Optimum Technology Matching®, Enabling Wireless Connectivity™, PowerStar®, POLARIS™ TOTAL RADIO™ and UltimateBlue™ are trademarks of RFMD, LLC. BLUETOOTH is a trademark owned by Bluetooth SIG, Inc., U.S.A. and licensed for use by RFMD. All other trade names, trademarks and registered trademarks are the property of their respective owners. ©2006, RF Micro Devices, Inc.

Absolute Maximum Ratings

Parameter	Rating	Unit
Supply Voltage	-0.5 to +7.5	V _{DC}
Input LO and RF Levels	+10	dBm
Operating Ambient Temperature	-40 to +85	°C
Storage Temperature	-40 to +150	°C



Caution! ESD sensitive device.

Exceeding any one or a combination of the Absolute Maximum Rating conditions may cause permanent damage to the device. Extended application of Absolute Maximum Rating conditions to the device may reduce device reliability. Specified typical performance or functional operation of the device under Absolute Maximum Rating conditions is not implied.

RoHS status based on EU Directive 2002/95/EC (at time of this document revision).

The information in this publication is believed to be accurate and reliable. However, no responsibility is assumed by RF Micro Devices, Inc. ("RFMD") for its use, nor for any infringement of patents, or other rights of third parties, resulting from its use. No license is granted by implication or otherwise under any patent or patent rights of RFMD. RFMD reserves the right to change component circuitry, recommended application circuitry and specifications at any time without prior notice.

Parameter	Specification			Unit	Condition
	Min.	Typ.	Max.		
Carrier Input					T=25°C, V _{CC} =5V
Frequency Range	800		2500	MHz	
Power Level	-6		+6	dBm	
Input VSWR		5:1			At 900MHz
		1.8:1			At 1800MHz
		1.2:1			At 2500MHz
Modulation Input					
Frequency Range	DC		250	MHz	
Reference Voltage (V _{REF})	2.0	3.0		V	
Maximum Modulation (I&Q)			V _{REF} ± 1.0	V	
Gain Asymmetry		0.2		dB	
Quadrature Phase Error		3		°	
Input Resistance		30		kΩ	
Input Bias Current			40	μA	
RF Output					LO=2GHz and -5dBm, I&Q=2.0V _{pp} SSB
Output Power	-3		+3	dBm	
Output Impedance		50		Ω	
Output VSWR		3.5:1			At 900MHz
		1.3:1			At 2000MHz
		1.15:1			At 2500MHz
Harmonic Output	-30	-35		dBc	
Sideband Suppression	25	35		dB	
Carrier Suppression	30	35		dB	
IM ₃ Suppression	30	35		dB	Intermodulation of the carrier and the desired RF signal
	25	30		dB	Intermodulation of baseband signals
Broadband Noise Floor					At 20MHz offset, V _{CC} =5V. Tied to V _{REF} : ISIG, QSIG, IREF, and QREF.
		-145		dBm/Hz	At 850MHz
		-152		dBm/Hz	At 1900MHz
Power Down					
Turn On/Off Time			100	ns	
PD Input Resistance	50			kΩ	
Power Control "ON"			2.8	V	Threshold voltage
Power Control "OFF"	1.0	1.2		V	Threshold voltage

Parameter	Specification			Unit	Condition
	Min.	Typ.	Max.		
Power Supply					
Voltage		5		V	Specifications
	4.5		6.0	V	Operating Limits
Current		45	50	mA	Operating
			25	μA	Power Down

NOT FOR NEW DESIGNS

Pin	Function	Description	Interface Schematic
1	I REF	Reference voltage for the I mixer. This voltage should be the same as the DC voltage supplied to the I SIG pin. A voltage of 3.0V is recommended. The SIG and REF inputs are inputs of a differential amplifier. Therefore the REF and SIG inputs are interchangeable. If swapping the I SIG and I REF pins, the Q SIG and Q REF also need to be swapped to maintain the correct phase. It is also possible to drive the SIG and REF inputs in a balanced mode. This will increase the gain.	
2	Q REF	Reference voltage for the Q mixer. This voltage should be the same as the DC voltage supplied to the Q SIG pin. A voltage of 3.0V is recommended.	
3	GND2	Ground connection of the LO phase shift network. This pin should be connected directly to the ground plane.	
4	GND2	Same as pin 3.	
5	GND2	Same as pin 3.	
6	LO	The input of the phase shifting network. This pin has an internal DC-blocking capacitor. At frequencies higher than 2GHz this port is well-matched to 50Ω. This port is voltage driven so matching at lower frequencies is not required.	
7	VCC1	Power supply for all circuits except the RF output stage. An external capacitor is needed if no other low frequency bypass capacitor is nearby.	
8	PD	Power Down control. When this pin is "low", all circuits are shut off. A "low" is typically 1.2V or less at room temperature. When this pin is "high" (V _{CC}), all circuits are operating normally. If PD is below V _{CC} , output power and performance will be degraded. Operating in this region is not recommended, although it might be useful in some applications where power control is required.	
9	RF OUT	This is the 50Ω RF Output. This pin has an internal DC-blocking capacitor. At frequencies higher than 2GHz this port is well-matched. Typical impedances at lower frequencies are: 24-j30 Ω @ 1GHz, 27-j10 Ω @ 1.4GHz, 31-j3 Ω @ 1.8GHz. At those frequencies, external matching may be needed to optimize output power.	
10	GND3	Ground connection for the RF output stage. This pin should be connected directly to the ground plane.	
11	VCC2	Power supply for the RF Output amplifier. An external capacitor is needed if no other low frequency bypass capacitor is near by.	
12	GND1	Ground connection for the LO and baseband amplifiers, and for the mixers. This pin should be connected directly to the ground plane.	
13	GND1	Same as pin 12.	
14	GND1	Same as pin 12.	
15	Q SIG	Baseband input to the Q mixer. This pin is DC-coupled. Maximum output power is obtained when the input signal has a peak to peak amplitude of 2V. The recommended DC level for this pin is 3.0V. The peak minimum voltage on this pin (V _{REF} - peak modulation amplitude) should never drop below 2.0V. The peak maximum voltage on this pin (V _{REF} + peak modulation amplitude) should never exceed 4.0V.	See pin 2.

Pin	Function	Description	Interface Schematic
16	I SIG	Baseband input to the I mixer. This pin is DC-coupled. Maximum output power is obtained when the input signal has a peak to peak amplitude of 2V. The recommended DC level for this pin is 3.0V. The peak minimum voltage on this pin ($V_{REF} - \text{peak modulation amplitude}$) should never drop below 2.0V. The peak maximum voltage on this pin ($V_{REF} + \text{peak modulation amplitude}$) should never exceed 4.0V.	See pin 1.

Package Drawing

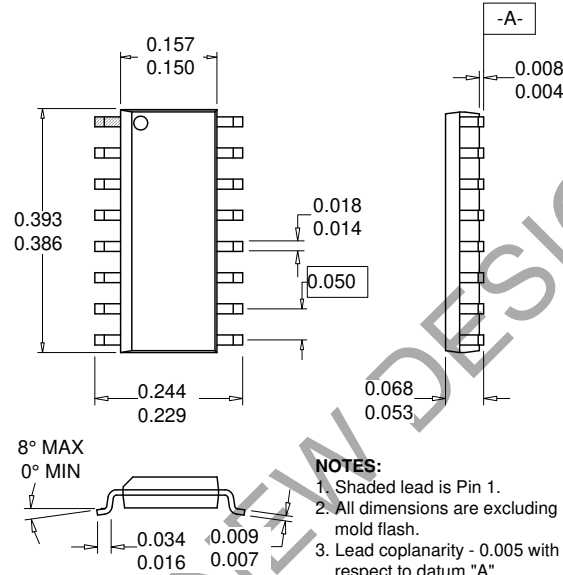

NOT FOR NEW DESIGNS

Application Schematic AC-Coupled

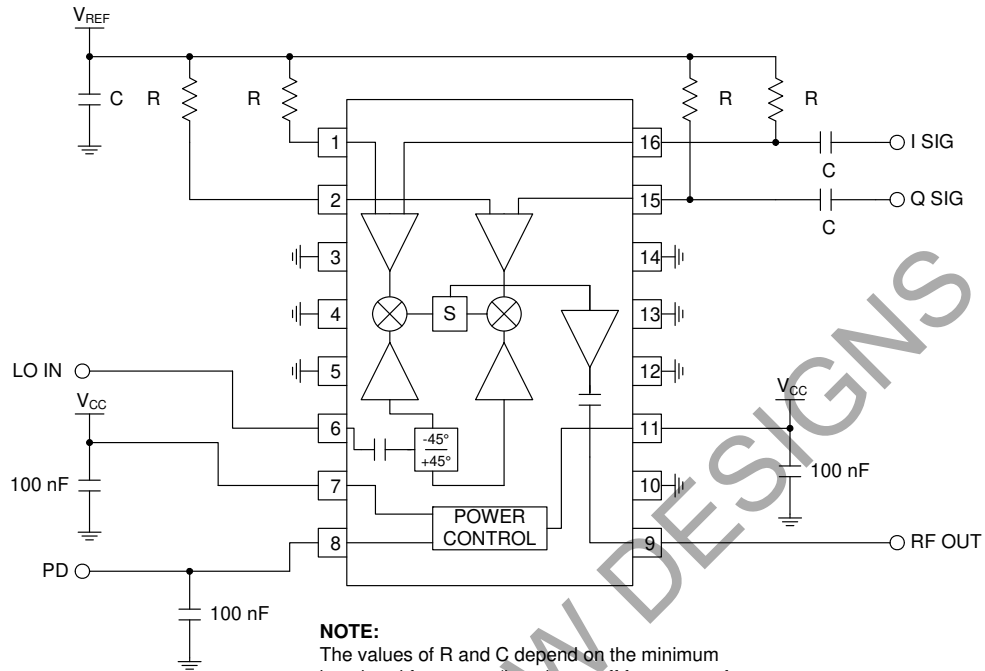

NOTE:
The values of R and C depend on the minimum baseband frequency (i.e., the cutoff frequency of this high pass filter should be lower than the lowest frequency component in the I/Q spectrum).

NOT FOR NEW DESIGNS

**Application Schematic
DC-Coupled**

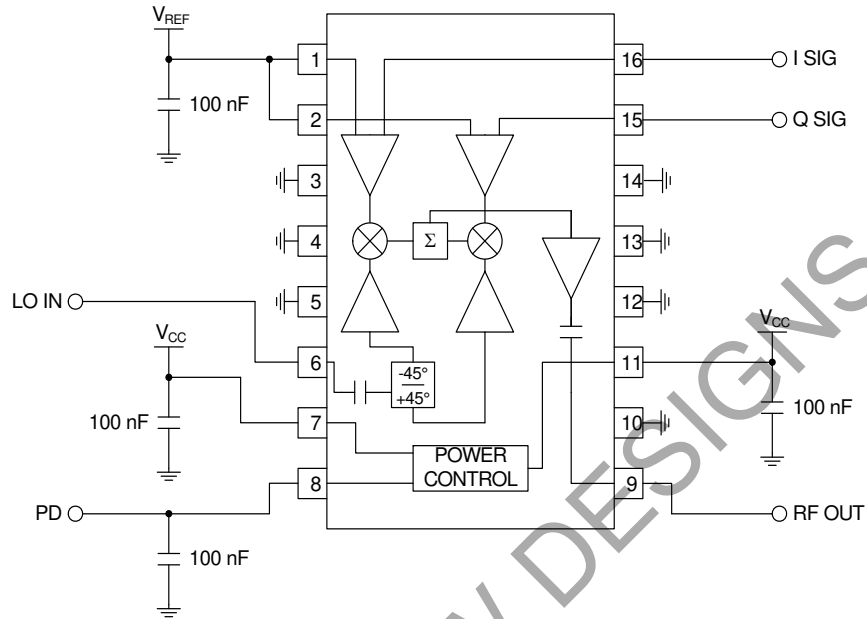

**Evaluation Board Schematic
1.5" x 1.5"**

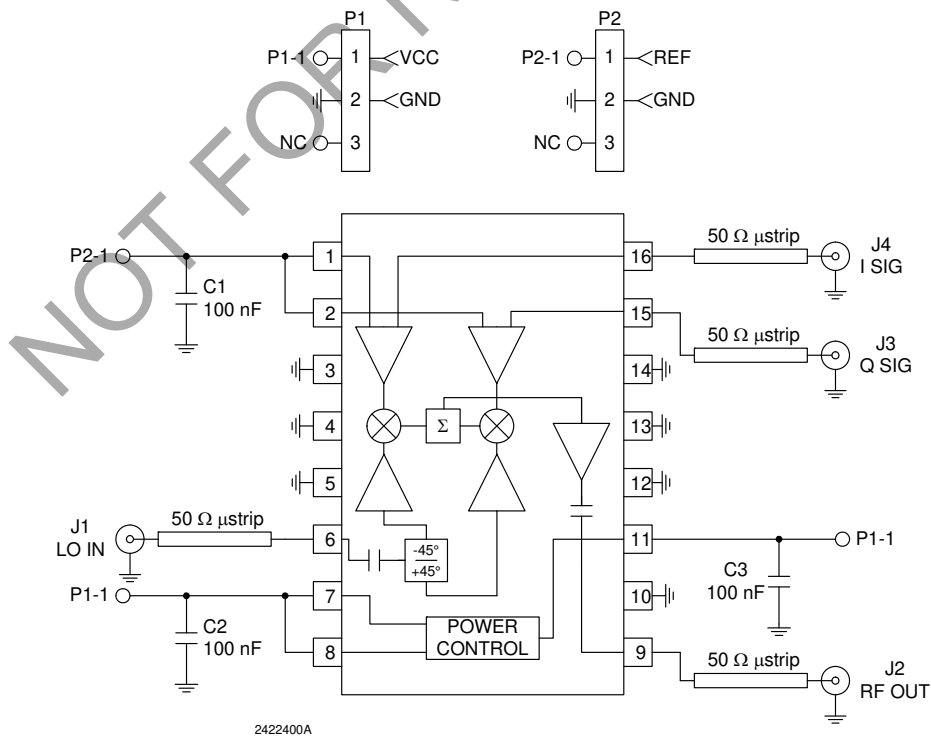

Evaluation Board Layout
Board Size 1.510" x 1.510"
Board Thickness 0.031", Board Material FR-4

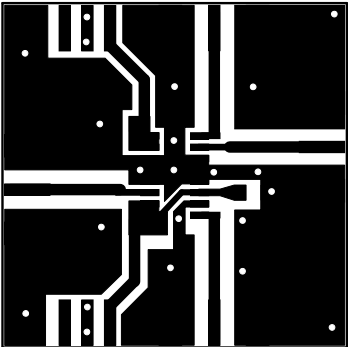
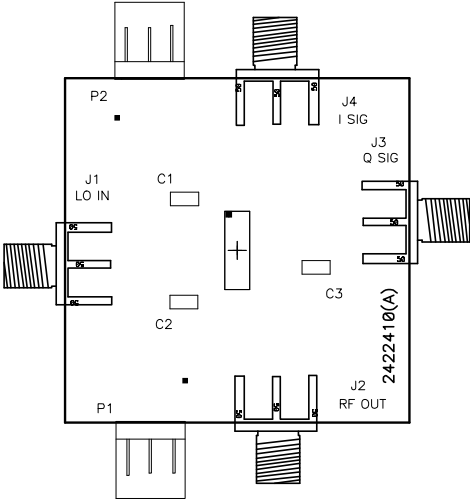

NOT FOR SALE
DESIGNS

RoHS* Banned Material Content

RoHS Compliant: Yes
 Package total weight in gram 0.147
 Compliance Date Code: 0520
 Bill of Materials Revision: Rev -
 Pb Free Category: e3

Bill of Materials	Parts Per Million (PPM)					
	Pb	Cd	Hg	Cr VI	PBB	PBDE
Die	0	0	0	0	0	0
Molding Compound	0	0	0	0	0	0
Lead Frame	0	0	0	0	0	0
Die Attach Epoxy	0	0	0	0	0	0
Wire	0	0	0	0	0	0
Solder Plating	0	0	0	0	0	0

This RoHS banned material content declaration was prepared solely on information, including analytical data, provided to RFMD by its suppliers, and applies to the Bill of Materials (BOM) revision noted above.

* DIRECTIVE 2002/95/EC OF THE EUROPEAN PARLIAMENT AND OF THE COUNCIL of 27 January 2003 on the restriction of the use of certain hazardous substances in electrical and electronic equipment

NOT FOR NEW DESIGNS