



Chipsmall Limited consists of a professional team with an average of over 10 year of expertise in the distribution of electronic components. Based in Hongkong, we have already established firm and mutual-benefit business relationships with customers from,Europe,America and south Asia,supplying obsolete and hard-to-find components to meet their specific needs.

With the principle of “Quality Parts,Customers Priority,Honest Operation,and Considerate Service”,our business mainly focus on the distribution of electronic components. Line cards we deal with include Microchip,ALPS,ROHM,Xilinx,Pulse,ON,Everlight and Freescale. Main products comprise IC,Modules,Potentiometer,IC Socket,Relay,Connector.Our parts cover such applications as commercial,industrial, and automotives areas.

We are looking forward to setting up business relationship with you and hope to provide you with the best service and solution. Let us make a better world for our industry!



Contact us

Tel: +86-755-8981 8866 Fax: +86-755-8427 6832

Email & Skype: info@chipsmall.com Web: www.chipsmall.com

Address: A1208, Overseas Decoration Building, #122 Zhenhua RD., Futian, Shenzhen, China





DATA SHEET

SNAP Engine 266 Series

Model Number: RF266

Part Number: RF266PC1

©2008-2014 Synapse, All Rights Reserved. All Synapse products are patent pending. Synapse, the Synapse logo, SNAP, and Portal are all registered trademarks of Synapse Wireless, Inc.

Doc# 430141-01C

6723 Odyssey Drive // Huntsville, AL 35806 // (877) 982-7888 // Synapse-Wireless.com

SNAP Engine 266 Series Modules Overview

The SNAP Engine 266 Series (Model RF266) is an IEEE 802.15.4, low power, highly-reliable solution to embedded wireless control and monitoring network needs that require high data rates. The RF266PC1 module is pin-compatible with Digi International's XBee® and XBee-PRO® RF modules, and comes pre-loaded with open source code for AT command emulation.

The RF266 embeds Synapse's SNAP OS, the industry's first Internet-enabled, wireless mesh network operating system into the Atmel ATmega128RFA1 single-chip AVR® microcontroller with an integrated transceiver that delivers up to 2Mbits/sec. These low-cost modules can have a range of up to 4,000 feet and current consumption as low as 1.18 μ A to enable a new generation of battery-driven systems.

SNAP's on-board Python interpreter provides for rapid application development and over-the-air programming, while Atmel's low-power RF single-chip design saves board space and lowers the overall Bill of Materials and power consumption. The RF266 is approved as an FCC Part 15 unlicensed modular transmitter. The modules provide up to 16 channels of operation in the ISM 2.4GHz frequency band. The RF266 contains both a power amplifier for transmission and a low noise amplifier in the receive path for extended range.

This Data Sheet details Part Number RF266PC1

- 15 GPIO, 4 with 10-bit ADC
- 128k flash, 58k free for over-the-air uploaded user apps
- One UART port
- Low power modes:
 - 1.18 μ A with internal timer off
 - 2.3 μ A with internal timer running
- Spread spectrum (DSSS) technology
- AES 128-bit encryption
- Socket-able or solder-able
- Up to 2 Mbps Data Rate
- 2.4 GHz RF Frequency
- Chip antenna (up to 4000 feet, LoS at 250kbps)
- 4K internal EEPROM
- I²C and SPI support
- 4 PWM outputs



Specifications

Table 1: RF266 Specifications at 25° C

Performance	Outdoor LOS Range	Up to 4,000 feet at 250Kbps
	Transmit Power Output	20 dBm
	RF Data Rate	250Kbps, 500Kbps, 1Mbps, 2Mbps
	Receiver Sensitivity	-103 dBm (1% PER)
Power Requirements	Supply Voltage	2.7 - 3.6 V
	Transmit Current (Typ@3.3V)	130mA
	Idle/Receive Current (Typ@3.3V)	25mA
	Power-down Current (Typ@3.3V)	1.18uA with internal timer off 2.3uA with internal timer running
General	Frequency	ISM 2.4 GHz
	Spreading Method	Direct Sequence (DSSS)
	Modulation	O-QPSK
	Dimensions	1.3" (H) x 1.0" (W)
	Operating Temperature	- 40 to 85 deg C.
	Antenna Options	Chip
Networking	Topology	SNAP
	Error Handling	Retries and acknowledgement
	Number of Channels	16
Available I/O	UARTS with HW Flow Control	1 port
	GPIO	15 total; 4 can be analog-in with 10bit ADC
Agency Approvals	FCC Part 15.247	FCC ID: U9O-RF266
	Industry Canada (IC)	IC: 7084A-RF266
	CE available as a custom part. Call for details.	

Module Pin Definitions

Table 2: RF266 Module Pin Assignments

Pin	SNAPpy IO	Name	Description
1		3.3V	Power Supply
2	11	IO_11 PD3 INT3 TXD1	IO_11, UART Data Out, Interrupt
3	10	IO_10 PD2 INT2 RXD1	IO_10, UART Data In, Interrupt
4	21	IO_21 PE5 INT5 OC3C	IO_21, PWM Output, Interrupt
5		RESET	Module Reset, Active Low
6	20	IO_20 PE4 INT4 OC3B	IO_20, PWM Output, Interrupt
7	19	IO_19 PE3 RTS0 OC3A AIN0	IO_19, PWM Output
8		-	No Connect
9	9	IO_9 PD1 INT1	IO_9, Interrupt, I ² C SDA
10		GND	
11	15	IO_15 PD7	IO_15
12	12	IO_12 PD4 CTS1 ICP1	IO_12, CTS Output
13	8	IO_8 PD0 INT0	IO_8, Interrupt, I ² C SCL
14		-	No Connect
15	37	IO_37 PG5 OC0B	IO_37, PWM Output
16	23	IO_23 PE7 INT7 ICP3	IO_23, RTS Input, Interrupt
17	31	IO_31 PF7 ADC7	IO_31, ADC7 Input
18	30	IO_30 PF6 ADC6	IO_30, ADC6 Input, SPI MOSI
19	29	IO_29 PF5 ADC5	IO_29, ADC5 Input, SPI SCLK
20	28	IO_28 PF4 ADC4	IO_28, ADC4 Input, SPI MISO

Electrical Characteristics

Table 3: RF266 DC Characteristics at 25° C

Symbol	Parameter	Condition	Min	Typ	Max	Units
V_{CC}^1	Supply Voltage		2.7	3.3	3.6	V
T_{OP}	Operating Temp		-40		85	°C
T_{STOR}	Storage Temp		-40		125	°C
V_{IH}	Input Hi Voltage	All Digital Inputs	$V_{CC} - 0.4$			V
V_{IL}	Input Low Voltage	All Digital Inputs			0.4	V
V_{OL}	Output Low Voltage	All drive strengths (2,4,6,8 mA)			0.4	V
V_{OH}	Output High Voltage	All drive strengths (2,4,6,8 mA)	$V_{CC} - 0.4$			V
$I_{L_{IN}}$	In Leakage Current	$V_{IN} = V_{CC}$ or V_{SS} , all Pins		<10 nA	1	μA
TX- I_{CC}	Transmit Current	$V_{CC} = 3.3V$		130		mA
RX- I_{CC}	Receive Current	$V_{CC} = 3.3V$		25		mA
SHDN- I_{CC}	Sleep Current	$V_{CC} = 3.3V$	1.18	2.3	963	μA

Table 4: ADC Electrical Characteristics (Operating)

Symbol	Parameter	Condition	Min	Typical	Max	Unit
V_{REFH}^2	Voltage Reference, High	Programmable	1.5	1.6	1.8	V
V_{INDC}	Analog input voltage	Single Ended	0		1.8	V
		Differential ³	0		3.3	

1 Absolute maximum stress rated voltage for VCC is -0.3 to 3.6. It is recommended that bulk capacitance be located as close as possible to the VCC pin on the host board. Ideally, use a single 47μF capacitor at 10V directly at the VCC pin.

2 VREFH is programmable to three fixed values; 1.5V, 1.6V, and 1.8V. The default is 1.6V.

3 Each differential analog input may be as high as 3.3V but the differential voltage is still limited.

Table 5: ADC Timing/Performance Characteristics

Symbol	Parameter	Condition	Min	Typical	Max	Unit
R_{AS}	Source impedance at input ⁴				3k	k Ω
RES	Conversion Resolution	Single Ended CLKADC \leq 4MHz		10		Bits
DNL	Differential non-linearity	$V_{REFH} = 1.6V$ CLKADC=4MHz	-0.5			LSB
INL	Integral non-linearity	$V_{REFH} = 1.6V$ CLKADC=4MHz		0.8		LSB
E_{ZS}	Zero-scale error			1.5		LSB
E_G	Gain error			1		LSB

Table 6: Reset, Brown-out and Internal Voltage Characteristics

Symbol	Parameter	Condition	Min	Typical	Max	Unit
V_{POT} (rising)	Power-on Reset Threshold Voltage (rising)	Power supply fully discharged		1.6		V
V_{POT} (falling)	Power-on Reset Threshold Voltage (falling)		0.05	0.3		V
t_{POT}	Power-on Reset recovery time	Time of EVDD/DEVDD < V_{POT}	1.0			ms
V_{PSR}	Power-on slope rate		1.8		3300	V/ms
V_{RST}	RSTN Pin Threshold Voltage		0.1V _{DD}		0.9V _{DD}	V
t_{RST}	Minimum pulse width on RSTN Pin			200	300	ns

⁴ Any analog source with a source impedance greater than 3k Ω will increase the sampling time.

Symbol	Parameter	Condition	Min	Typical	Max	Unit
V_{HYS}	Brown-out Detector Hysteresis			7.5	50	mV
t_{BOD}	Min Pulse Width on Brown-out Reset			100		ns

Contact ATMEL for additional details

Mechanical Drawings

The drawings in **Figure 1** show the RF266 module mechanical specifications.

NOTE: The area under the module's antenna (marked NO COPPER or KEEP OUT AREA) should have no components, no traces, and no copper on any layer of the printed circuit board.

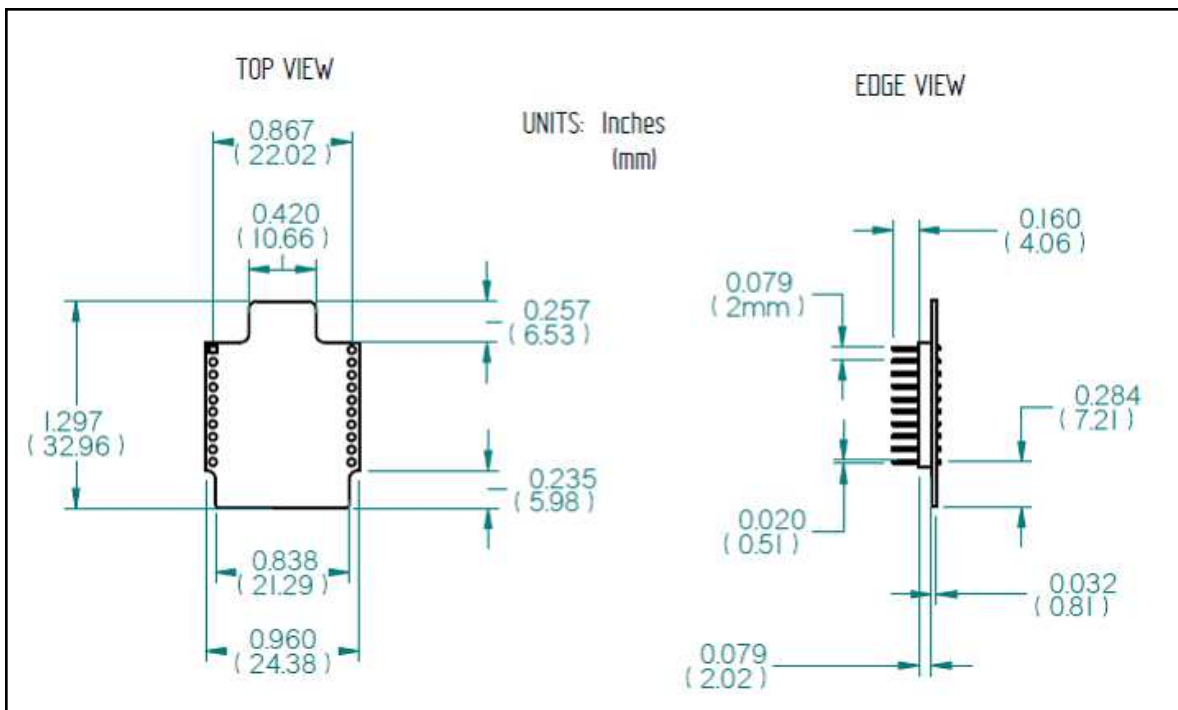

Figure 1: Mechanical drawings of the RF266 Module

Board Mounting Considerations

The RF266 module is designed to mount into a receptacle (socket) on the host board. **Figure 2** shows an RF266 module plugged in to an example host board. The receptacle sockets are on standard 2mm centers. Suggested receptacles to be used on the host are:

Thru-hole receptacle	Samtec	MMS-110-01-L-SV
----------------------	--------	-----------------

Surface mount receptacle	Samtec	MMS-110-02-L-SV
--------------------------	--------	-----------------

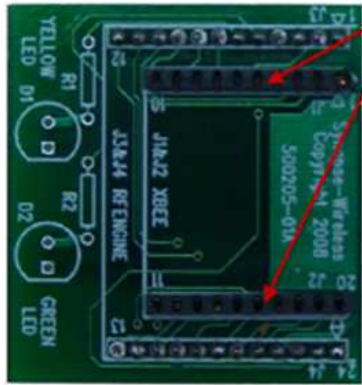

Host Board Example

Sockets for RF26X Module

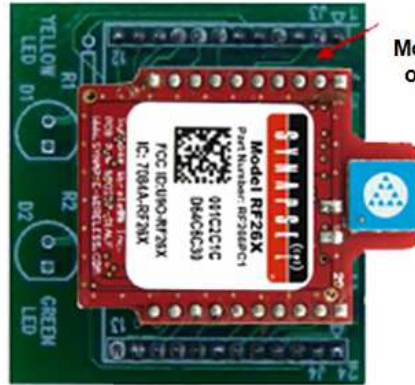

RF266PC1 Mounted

RF266PC1 Module mounted on host board.

Figure 2: RF266PC1 mounted to an example host board

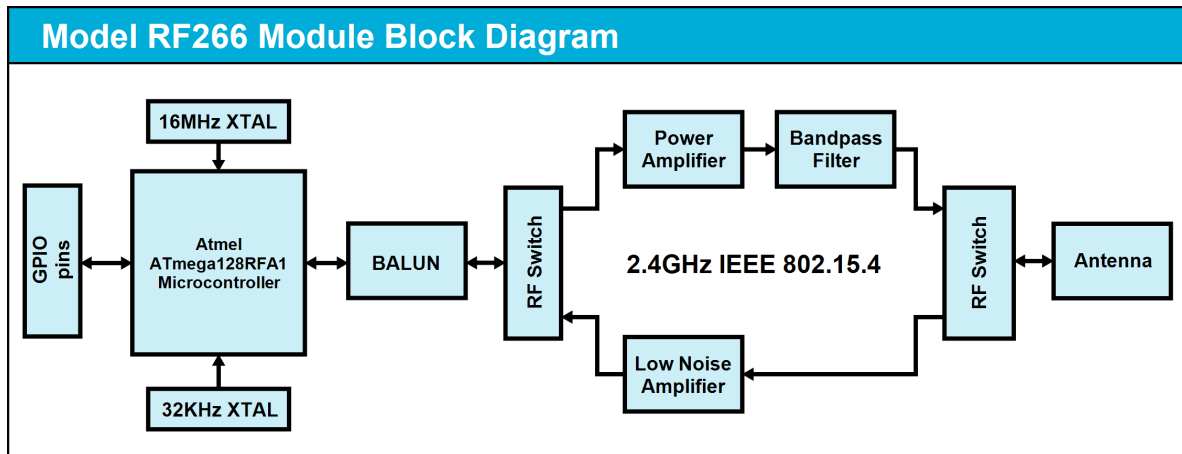

Figure 3: Block diagram showing the major subsystems comprising the RF266

Agency Certifications

United States (FCC)

The Model RF266 modules comply with Part 15 of the FCC rules and regulations. Compliance with the labeling requirements, FCC notices, and antenna usage guidelines is required. In order to comply with FCC Certification requirements, the Original Equipment Manufacturer (OEM) must fulfill the following requirements.

1. The system integrator must place an exterior label on the outside of the final product housing the RF266 Modules. **Figure 1** below shows the contents that must be included on this label.
2. RF266 Modules may only be used with the antenna that has been tested and approved for use with the module. Please refer to the antenna table provided in this section.

OEM Labeling Requirements

NOTICE: The OEM must make sure that FCC labeling requirements are met. This includes a clearly visible exterior label on the outside of the final product housing that displays the contents shown in **Figure 1** below.

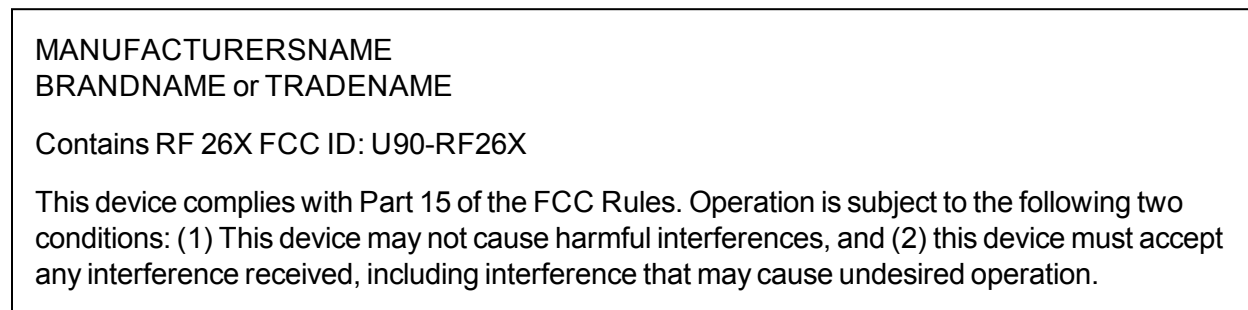

Figure 1: FCC Label

FCC Notices

WARNING! The RF266 modules have been tested by the FCC for use with other products without further certification (as per FCC Section 2.1091). Changes or modifications to this device not expressly approved by Synapse Wireless Inc. could void the user's authority to operate the equipment.

NOTICE: OEM's must certify final end product to comply with unintentional radiators (FCC Sections 15.107 and 15.109) before declaring compliance of their final product to Part 15 of the FCC Rules.

NOTICE: The RF266 modules have been certified for remote and base radio applications. If the module will be used for portable applications as defined by the FCC, the device must undergo SAR testing.

This equipment has been tested and found to comply with the limits for a Class B digital device, pursuant to Part 15 of the FCC Rules. These limits are designed to provide reasonable protection against harmful interference in a residential installation. This equipment generates, uses, and can radiate radio frequency energy, and if not installed and used in accordance with the instructions, may cause harmful interference to radio communications. However, there is no guarantee that interference will not occur in a particular installation.

If this equipment does cause harmful interference to radio or television reception, which can be determined by turning the equipment off and on, the user is encouraged to try to correct the interference by one or more of the following measures:

- Reorient or relocate the receiving antenna.
- Increase the separation between the equipment and receiver.
- Connect the equipment into an outlet on a circuit different from that to which the receiver is connected.
- Consult the dealer or an experienced radio/TV technician for help.

FCC Approved Antennas

The RF266 modules are FCC-approved for fixed base station and mobile applications.

NOTICE: To reduce potential radio interference to other users, the antenna type and its gain should be chosen so that the equivalent isotropically radiated power (EIRP) is not more than that permitted for successful communication. This module has been designed to operate with the antennas listed below in **Table 1**. The required antenna impedance is 50 ohms.

Table 1: Approved FCC Antennas

Part Number	Type	Gain	Application	Min. Separation
Fractus: FR05-S1-N-0-001	Chip Antenna	1.9 dBi	Fixed/Mobile	20 cm.

For more information on approved antennas, please consult the manufacturer's website.

WARNING! RF Exposure: This equipment complies with FCC radiation exposure limits set forth for an uncontrolled environment. This equipment should be installed and operated with minimum distance 20cm between the radiator and your body. This transmitter must not be co-located or operating in conjunction with any other antenna or transmitter.

NOTE: Antenna and transmitters may be Co-Located or operated in conjunction with this device only if the transmitters do not simultaneously transmit. Otherwise, additional regulatory requirements will apply.

NOTICE: The preceding statements must be included as a CAUTION statement in OEM product manuals in order to alert users of FCC RF exposure compliance.

Canada (IC)

This device complies with Industry Canada license-exempt RSS standard(s). Operation is subject to the following two conditions: (1) this device may not cause interference, and (2) this device must accept any interference, including interference that may cause undesired operation of the device.

Le présent appareil est conforme aux CNR d'Industrie Canada applicables aux appareils radio exempts de licence. L'exploitation est autorisée aux deux conditions suivantes : (1) l'appareil ne doit pas produire de brouillage, et (2) l'utilisateur de l'appareil doit accepter tout brouillage radioélectrique subi, même si le brouillage est susceptible d'en compromettre le fonctionnement.

Under Industry Canada regulations, this radio transmitter may only operate using an antenna of a type and maximum (or lesser) gain approved for the transmitter by Industry Canada. To reduce potential radio interference to other users, the antenna type and its gain should be so chosen that the equivalent isotropically radiated power (EIRP) is not more than that necessary for successful communication.

Conformément à la réglementation d'Industrie Canada, le présent émetteur radio peut fonctionner avec une antenne d'un type et d'un gain maximal (ou inférieur) approuvé pour l'émetteur par Industrie Canada. Dans le but de réduire les risques de brouillage radioélectrique à l'intention des autres utilisateurs, il faut choisir le type d'antenne et son gain de sorte que la puissance isotrope rayonnée équivalente (p.i.r.e.) ne dépasse pas l'intensité nécessaire à l'établissement d'une communication satisfaisante.

This radio transmitter Model: RF266, IC: 7084A-RF266 has been approved by Industry Canada to operate with the antenna types listed below with the maximum permissible gain and required antenna impedance for each antenna type indicated. Antenna types not included in this list, having a gain greater than the maximum gain indicated for that type, are strictly prohibited for use with this device.

Le présent émetteur radio Model: RF266, IC: 7084A-RF266 a été approuvé par Industrie Canada pour fonctionner avec les types d'antenne énumérés ci-dessous et ayant un gain admissible maximal et l'impédance requise pour chaque type d'antenne. Les types d'antenne non inclus dans cette liste, ou dont le gain est supérieur au gain maximal indiqué, sont strictement interdits pour l'exploitation de l'émetteur

Table 2: Approved IC Antennas

Part Number	Type	Gain	Application	Min. Separation
Fractus: FR05-S1-N-0-001	Chip Antenna	1.9 dBi	Fixed/Mobile	20 cm.

OEM Labeling Requirements

Labeling requirements for Industry Canada are similar to those of the FCC. A clearly visible label on the outside of the final product housing must display the contents shown in **Figure 2**.

MANUFACTURERSNAME
BRANDNAME or TRADENAME
MODEL:
Contains RF 26X IC: 7084A-RF26X

Figure 2: IC Label

NOTE: The OEM can choose to implement a single label combined for both FCC and IC labeling requirements. If a combined single label is chosen, there must be a clearly visible label on the outside of the final product housing displaying the contents shown in **Figure 3** .

MANUFACTURERSNAME
BRANDNAME or TRADENAME
Contains RF 26X FCC ID: U90-RF26X
Contains RF 26X IC: 7084A-RF26X
This device complies with Part 15 of the FCC Rules. Operation is subject to the following two conditions: (1) This device may not cause harmful interferences, and (2) this device must accept any interference received, including interference that may cause undesired operation.

Figure 3: Combined FCC and IC Label